

**用途**

- 应用于功率放大器

**产品特性**

- 高集电极电压:  $V_{CEO}=-230V$  (min)
- 与 2SC4793 互补
- 高转换频率:  $f_T=70MHz$ (Typ.)
- 环保 (RoHS) 产品

**APPLICATIONS**

- Power Amplifier Applications

**FEATURES**

- High collector voltage:  $V_{CEO}=-230V$  (min)
- Complementary to 2SC4793
- High transition frequency : $f_T=70MHz$ (Typ.)
- RoHS product

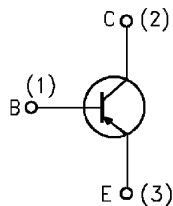
**封装 Package**

**订货信息 ORDER MESSAGE**

订货型号 Order codes	印记 Marking	无卤素 Halogen Free	封装 Package	包装 Packaging
2SA1837-O	2SA1837	否 NO	TO-220F	条管 Tube

**绝对最大额定值 ABSOLUTE RATINGS ( $T_c=25^\circ C$  unless otherwise noted)**

项 目 Parameter	符 号 Symbol	数 值 Value	单 位 Unit
集电极—发射极直流电压 Collector- Emitter Voltage	$V_{CBO}$	-230	V
集电极—发射极直流电压 Collector- Emitter Voltage ( $I_B=0$ )	$V_{CEO}$	-230	V
发射极—基极直流电压 Emitter-Base Voltage	$V_{EBO}$	-5	V
最大集电极直流电流 Collector Current (DC)	$I_C$	-1	A
最大基极电流 Base Current	$I_B$	-0.1	A
最大集电极耗散功率 Collector Dissipation( $T_a=25^\circ C$ )	$P_C$	2.0	W
最大集电极耗散功率 Collector Dissipation( $T_c=25^\circ C$ )		20	W
最高结温 Junction Temperature	$T_j$	150	$^\circ C$
贮存温度 Storage Temperature	$T_{stg}$	-55~+150	$^\circ C$

**热特性 THERMAL CHARACTERISTIC**

项 目 Parameter	符 号 Symbo	最小值 min	最大值 max	单 位 Unit
结到环境的热阻 Thermal Resistance Junction Ambient TO-220F	$R_{th(j-a)}$	-	62.5	$^\circ C/W$
结到管壳的热阻 Thermal Resistance Junction Case TO-220F	$R_{th(j-c)}$	-	6.25	$^\circ C/W$

**电特性 ELECTRICAL CHARACTERISTIC**

项 目 Parameter	测试条件 Tests conditions	最小值 Value(min)	典型值 Value(typ)	最大值 Value(max)	单位 Unit
$I_{CBO}$	$V_{CE}=-230V, I_E=0$	-	-	-1.0	$\mu A$
$I_{EBO}$	$V_{EB}=-5V, I_C=0$	-	-	-1.0	$\mu A$
$V_{(BR)CEO}$	$I_C=-10mA, I_B=0$	-230	-	-	V
hFE	$V_{CE}=-5V, I_C=0.1A$	100	160	270	-
$V_{CE(sat)}$	$I_C=-0.5A, I_B=-0.05A$	-	-	-1.5	V
$V_{BE(ON)}$	$V_{CE}=-5V, I_C=-0.5A$	-	-	-1.0	V
$f_T$	$V_{CE}=-10V, I_C=-0.1A,$	-	70	-	MHz
Cob	$V_{CB}=-10V, I_E=0, f=1MHz$	-	30	-	pF

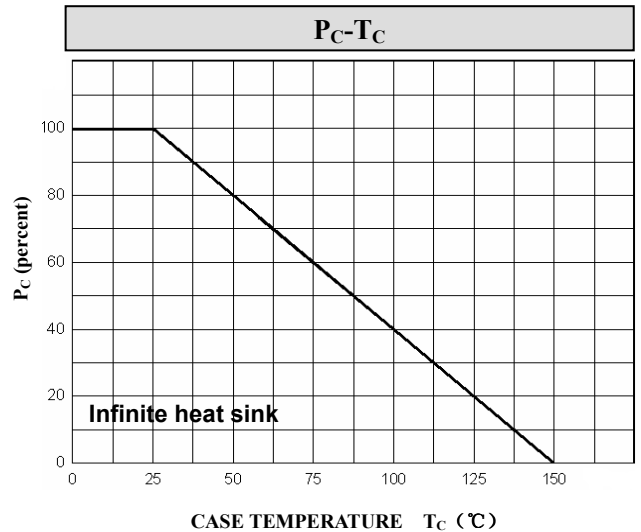
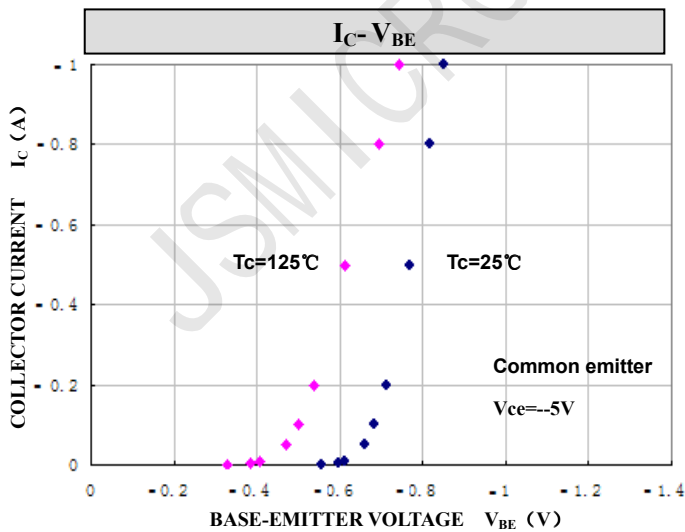
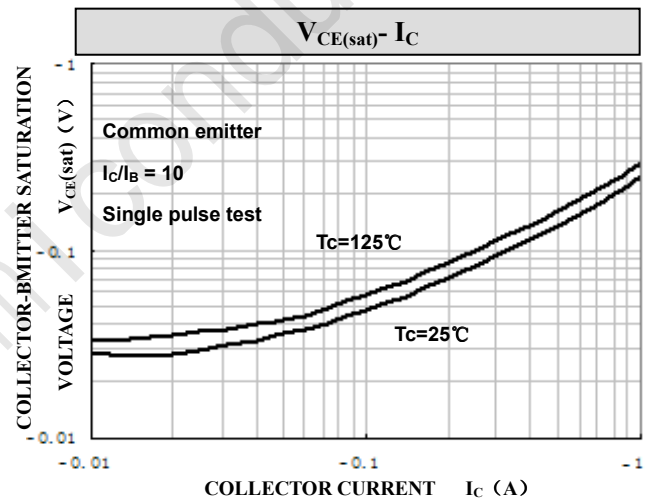
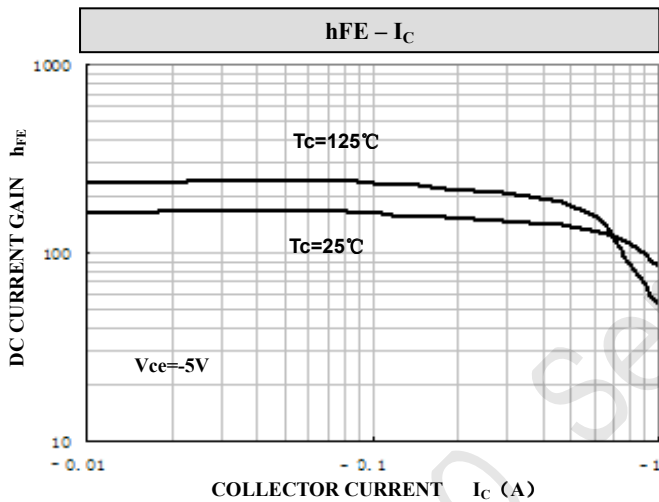
**特征曲线 ELECTRICAL CHARACTERISTICS (curves)**

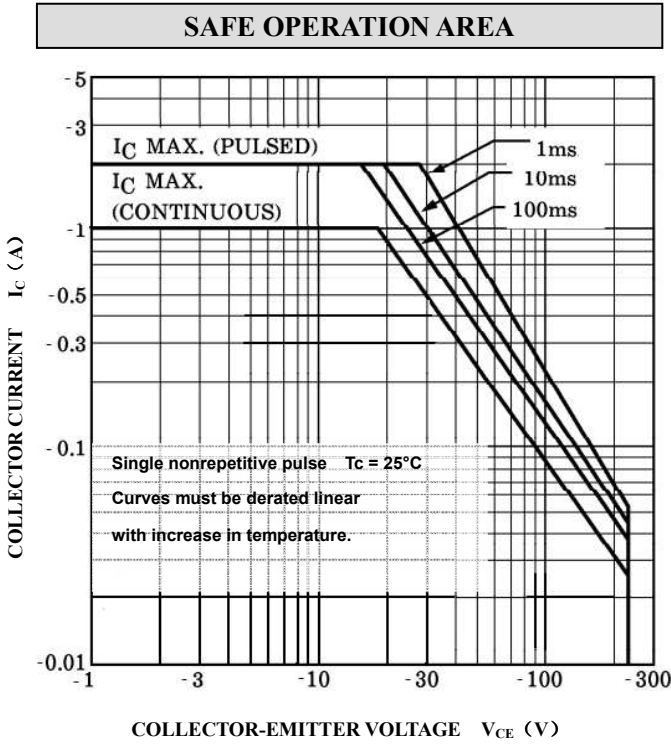

**外形尺寸 PACKAGE MECHANICAL DATA**  
**TO-220F**

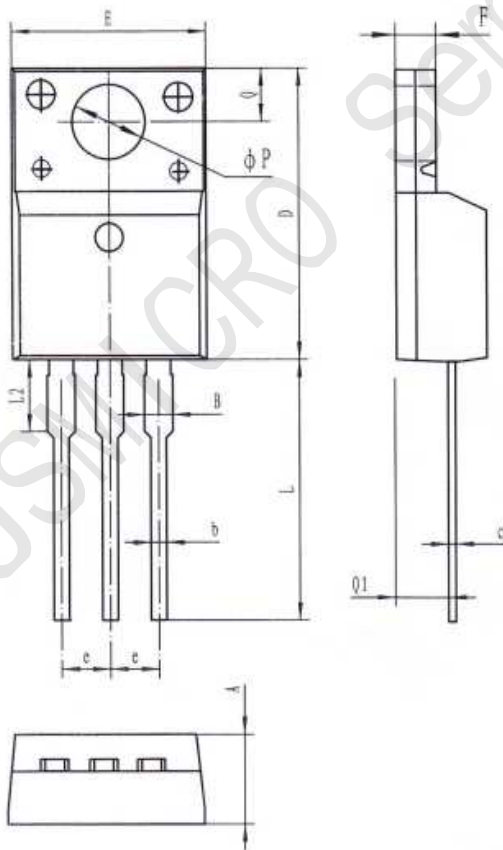
单位 Unit : mm



符号	尺寸 (mm)
<b>A</b>	4.50-4.90
<b>B</b>	<1.47
<b>b</b>	0.70-0.90
<b>c</b>	0.45-0.60
<b>D</b>	15.67-16.07
<b>E</b>	9.96-10.36
<b>e</b>	2.54TYPE
<b>F</b>	2.34-2.74
<b>L</b>	12.58-13.38
<b>L2</b>	3.13-3.33
<b>P</b>	3.08-3.28
<b>Q</b>	3.2-3.4
<b>Q1</b>	2.56-2.96