

Energy saving VIPerPlus: HV switching regulator for flyback converter

Datasheet - production data

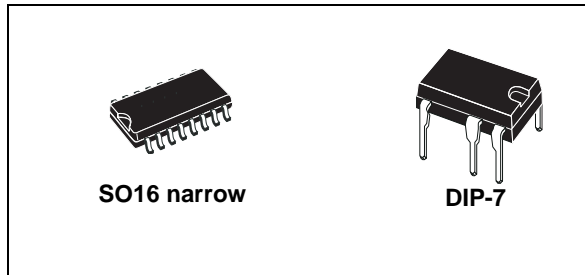
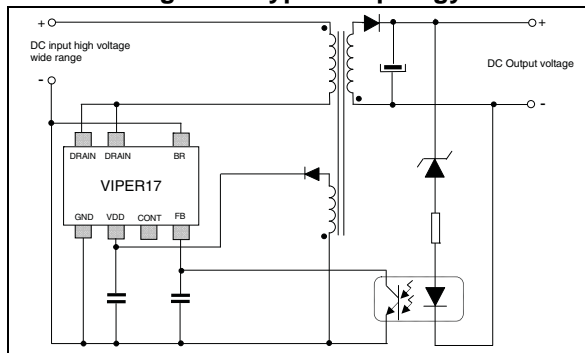

Figure 1. Typical topology



Features

- 800 V avalanche rugged power section
- PWM operation with frequency jittering for low EMI
- Operating frequency:
 - 60 kHz for L type
 - 115 kHz for H type
- Standby power < 30 mW at 265 Vac
- Limiting current with adjustable set point
- Adjustable and accurate overvoltage protection

- On-board soft-start
- Safe auto-restart after a fault condition
- Hysteresis thermal shutdown

Applications

- Adapters for PDA, camcorders, shavers, cellular phones, videogames
- Auxiliary power supply for LCD/PDP TV, monitors, audio systems, computer, industrial systems, LED driver, No el-cap LED driver
- SMPS for set-top boxes, DVD players and recorders, white goods

Description

The device is an off-line converter with an 800 V rugged power section, a PWM control, two levels of overcurrent protection, overvoltage and overload protections, hysteresis thermal protection, soft-start and safe auto-restart after any fault condition removal. The burst mode operation and the device's very low consumption meet the standby energy saving regulations.

Advance frequency jittering reduces EMI filter cost. Brown-out function protects the switch mode power supply when the rectified input voltage level is below the normal minimum level specified for the system. The high voltage start-up circuit is embedded in the device.

Table 1. Device summary

Order codes	Package	Packaging
VIPER17LN / VIPER17HN	DIP-7	Tube
VIPER17HD / VIPER17LD	SO16 narrow	Tube
VIPER17HDTR / VIPER17LDTR		Tape and reel

Contents

1	Block diagram	3
2	Typical power	3
3	Pin settings	4
4	Electrical data	6
	4.1 Maximum ratings	6
	4.2 Thermal data	6
	4.3 Electrical characteristics	7
5	Typical electrical characteristics	11
6	Typical circuit	14
7	Operation descriptions	15
	7.1 Power section and gate driver	15
	7.2 High voltage startup generator	15
	7.3 Power-up and soft-start up	15
	7.4 Power down operation	18
	7.5 Auto restart operation	18
	7.6 Oscillator	19
	7.7 Current mode conversion with adjustable current limit set point	19
	7.8 Overvoltage protection (OVP)	19
	7.9 About CONT pin	21
	7.10 Feed-back and overload protection (OLP)	22
	7.11 Burst-mode operation at no load or very light load	24
	7.12 Brown-out protection	25
	7.13 2nd level overcurrent protection and hiccup mode	27
8	Package mechanical data	28
9	Revision history	32

1 Block diagram

Figure 2. Block diagram

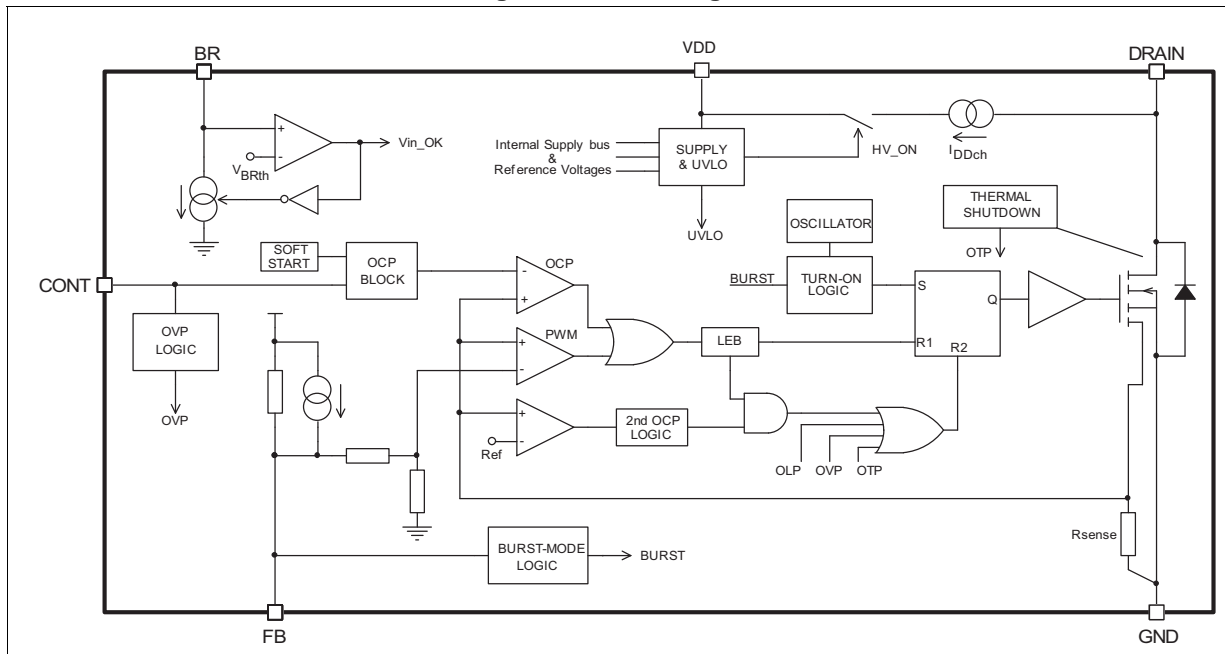

2 Typical power

Table 2. Typical power

Part number	230 V _{AC}		85-265 V _{AC}	
	Adapter ⁽¹⁾	Open frame ⁽²⁾	Adapter ⁽¹⁾	Open frame ⁽²⁾
VIPER17	9 W	10 W	5 W	6 W

1. Typical continuous power in non ventilated enclosed adapter measured at 50 °C ambient.
2. Maximum practical continuous power in an open frame design at 50 °C ambient, with adequate heat sinking.

3 Pin settings

Figure 3. Connection diagram (top view)

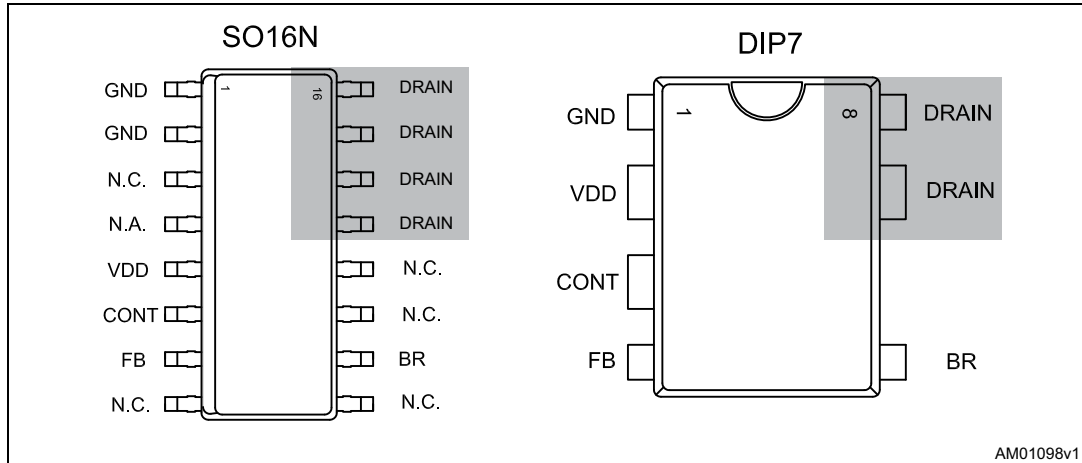

Note: The copper area for heat dissipation has to be designed under the DRAIN pins.

Table 3. Pin description

Pin N.		Name	Function
DIP-7	SO16		
1	1..2	GND	This pin represents the device ground and the source of the power section.
-	4	N.A.	Not available for user. This pin is mechanically connected to the controller die pad of the frame. In order to improve the noise immunity, is highly recommended connect it to GND (pin 1-2).
2	5	VDD	Supply voltage of the control section. This pin also provides the charging current of the external capacitor during start-up time.
3	6	CONT	Control pin. The following functions can be selected: 1. current limit set point adjustment. The internal set default value of the cycle-by-cycle current limit can be reduced by connecting to ground an external resistor. 2. output voltage monitoring. A voltage exceeding V_{OVP} threshold (see Table 8) shuts the IC down reducing the device consumption. This function is strobed and digitally filtered for high noise immunity.
4	7	FB	Control input for duty cycle control. Internal current generator provides bias current for loop regulation. A voltage below the threshold V_{FBbm} activates the burst-mode operation. A level close to the threshold V_{FBlin} means that we are approaching the cycle-by-cycle over-current set point.

Table 3. Pin description (continued)

Pin N.		Name	Function
DIP-7	SO16		
5	10	BR	Brownout protection input with hysteresis. A voltage below the threshold V_{BRth} shuts down (not latch) the device and lowers the power consumption. Device operation restarts as the voltage exceeds the threshold $V_{BRth} + V_{BRhyst}$. It can be connected to ground when not used.
7,8	13...16	DRAIN	High voltage drain pin. The built-in high voltage switched start-up bias current is drawn from this pin too. Pins connected to the metal frame to facilitate heat dissipation.

4 Electrical data

4.1 Maximum ratings

Table 4. Absolute maximum ratings

Symbol	Pin (DIP7)	Parameter	Value		Unit
			Min	Max	
V _{DRAIN}	7, 8	Drain-to-source (ground) voltage		800	V
E _{AV}	7, 8	Repetitive avalanche energy (limited by T _J = 150 °C)		2	mJ
I _{AR}	7, 8	Repetitive avalanche current (limited by T _J = 150 °C)		1	A
I _{DRAIN}	7, 8	Pulse drain current		2.5	A
V _{CONT}	3	Control input pin voltage (with I _{CONT} = 1 mA)	-0.3	Self limited	V
V _{FB}	4	Feed-back voltage	-0.3	5.5	V
V _{BR}	5	Brown-out input pin voltage (with I _{BR} = 0.5 mA)	-0.3	Self limited	V
V _{DD}	2	Supply voltage (I _{DD} = 25 mA)	-0.3	Self limited	V
I _{DD}	2	Input current		25	mA
P _{TOT}		Power dissipation at T _A < 40 °C (DIP-7)		1	W
		Power dissipation at T _A < 60 °C (SO16N)		1	W
T _J		Operating junction temperature range	-40	150	°C
T _{STG}		Storage temperature	-55	150	°C
ESD _(HBM)	1 to 8	Human body model		4	kV
ESD _(CDM)	1 to 8	Charge device model		1.5	kV

4.2 Thermal data

Table 5. Thermal data

Symbol	Parameter	Max value SO16N	Max value DIP7	Unit
R _{thJP}	Thermal resistance junction pin (dissipated power = 1 W)	35	40	°C/W
R _{thJA}	Thermal resistance junction ambient (dissipated power = 1 W)	90	110	°C/W
R _{thJA}	Thermal resistance junction ambient ⁽¹⁾ (dissipated power = 1 W)	80	90	°C/W

1. When mounted on a standard single side FR4 board with 100 mm² (0.155 sq in) of Cu (35 μm thick)

4.3 Electrical characteristics

($T_J = -25$ to 125 °C, $V_{DD} = 14$ V^(a); unless otherwise specified)

Table 6. Power section

Symbol	Parameter	Test condition	Min	Typ	Max	Unit
V_{BVDSS}	Break-down voltage	$I_{DRAIN} = 1$ mA, $V_{FB} = GND$ $T_J = 25$ °C	800			V
I_{OFF}	OFF state drain current	$V_{DRAIN} = 640$ V $V_{FB} = GND$			60	μA
		$V_{DRAIN} = 800$ V $V_{FB} = GND$			75	μA
$R_{DS(on)}$	Drain-source on state resistance	$I_{DRAIN} = 0.2$ A, $V_{FB} = 3$ V, $V_{BR} = GND$, $T_J = 25$ °C		20	24	Ω
		$I_{DRAIN} = 0.2$ A, $V_{FB} = 3$ V, $V_{BR} = GND$, $T_J = 125$ °C		40	48	Ω
C_{OSS}	Effective (energy related) output capacitance	$V_{DRAIN} = 0$ to 640 V		10		pF

Table 7. Supply section

Symbol	Parameter	Test condition	Min	Typ	Max	Unit
Voltage						
V_{DRAIN_START}	Drain-source start voltage		60	80	100	V
I_{DDch}	Start up charging current	$V_{DRAIN} = 120$ V, $V_{BR} = GND$, $V_{FB} = GND$, $V_{DD} = 4$ V	-2	-3	-4	mA
		$V_{DRAIN} = 120$ V, $V_{BR} = GND$, $V_{FB} = GND$, $V_{DD} = 4$ V after fault.	-0.4	-0.6	-0.8	mA
V_{DD}	Operating voltage range	After turn-on	8.5		23.5	V
$V_{DDclamp}$	V_{DD} clamp voltage	$I_{DD} = 20$ mA	23.5			V
V_{DDon}	V_{DD} start up threshold	$V_{DRAIN} = 120$ V, $V_{BR} = GND$, $V_{FB} = GND$	13	14	15	V
V_{DDoff}	V_{DD} under voltage shutdown threshold		7.5	8	8.5	V
$V_{DD(RESTART)}$	V_{DD} restart voltage threshold	$V_{DRAIN} = 120$ V, $V_{BR} = GND$, $V_{FB} = GND$	4	4.5	5	V

a. Adjust V_{DD} above V_{DDon} start-up threshold before settings to 14 V.

Table 7. Supply section (continued)

Symbol	Parameter	Test condition	Min	Typ	Max	Unit
Current						
I_{DD0}	Operating supply current, not switching	$V_{FB} = GND, F_{SW} = 0 \text{ kHz}, V_{BR} = GND, V_{DD} = 10 \text{ V}$			0.9	mA
I_{DD1}	Operating supply current, switching	$V_{DRAIN} = 120 \text{ V}, F_{SW} = 60 \text{ kHz}$			1.8	mA
		$V_{DRAIN} = 120 \text{ V}, F_{SW} = 115 \text{ kHz}$			2	mA
I_{DD_FAULT}	Operating supply current, with protection tripping				400	μA
I_{DD_OFF}	Operating supply current with $V_{DD} < V_{DD_off}$	$V_{DD} = 5 \text{ V}$			270	μA

Table 8. Controller section

Symbol	Parameter	Test condition	Min	Typ	Max	Unit
Feed-back pin						
V_{FBolp}	Overload shut down threshold		4.5	4.8	5.2	V
V_{FBlin}	Linear dynamics upper limit		3.2	3.3	3.4	V
V_{FBbm}	Burst mode threshold	Voltage falling	0.4	0.45	0.6	V
$V_{FBbmhys}$	Burst mode hysteresis	Voltage rising		50		mV
I_{FB}	Feed-back sourced current	$V_{FB} = 0.3 \text{ V}$	-150	-200	-280	μA
		$3.3 \text{ V} < V_{FB} < 4.8 \text{ V}$		-3		μA
$R_{FB(DYN)}$	Dynamic resistance	$V_{FB} < 3.3 \text{ V}$	14		19	$\text{k}\Omega$
H_{FB}	$\Delta V_{FB} / \Delta I_D$		4		9	V/A
CONT pin						
V_{CONT_l}	Low level clamp voltage	$I_{CONT} = -100 \mu\text{A}$		0.5		V
V_{CONT_h}	High level clamp voltage	$I_{CONT} = 1 \text{ mA}$,	5	5.5	6	V
Current limitation						
I_{Dlim}	Max drain current limitation ⁽¹⁾	$V_{FB} = 4 \text{ V}, I_{CONT} = -10 \mu\text{A}, T_J = 25 \text{ }^\circ\text{C}$	0.38	0.4	0.42	A
t_{SS}	Soft-start time			8.5		ms
T_{ON_MIN}	Minimum turn ON time		220	400	480	ns
t_d	Propagation delay	(2)		100		ns
t_{LEB}	Leading edge blanking	(2)		300		ns
I_{D_BM}	Peak drain current during burst mode	$V_{FB} = 0.6 \text{ V}$		90		mA

Table 8. Controller section (continued)

Symbol	Parameter	Test condition	Min	Typ	Max	Unit
Oscillator section						
F _{OSC}	VIPER17L	V _{DD} = operating voltage range, V _{FB} = 1 V	54	60	66	kHz
	VIPER17H		103	115	127	kHz
FD	Modulation depth	VIPER17L		±4		kHz
		VIPER17H		±8		kHz
FM	Modulation frequency		250		Hz	
D _{MAX}	Maximum duty cycle		70		80	%
Overcurrent protection (2nd OCP)						
I _{DMAX}	Second over current threshold	(2)		0.6		A
Overvoltage protection						
V _{OVP}	Overvoltage protection threshold		2.7	3	3.3	V
T _{STROBE}	Overvoltage protection strobe time			2.2		µs
Brown out protection						
V _{BRth}	Brown out threshold	Voltage falling	0.41	0.45	0.49	V
V _{BRhyst}	Voltage hysteresis above V _{BRth}			50		mV
I _{BRhyst}	Current hysteresis		7		12	µA
V _{BRclamp}	Clamp voltage	I _{BR} = 250 µA		3		V
V _{DIS}	Brown out disable voltage		50		150	mV
Thermal shutdown						
T _{SD}	Thermal shutdown temperature	(2)	150	160		°C
T _{HYST}	Thermal shutdown hysteresis	(2)		30		°C

1. I_{Dim} @ V_{DD} lower than 10 V can range between -5% and +15%.
2. Specification assured by design, characterization and statistical correlation.

Figure 4. Minimum turn-on time test circuit

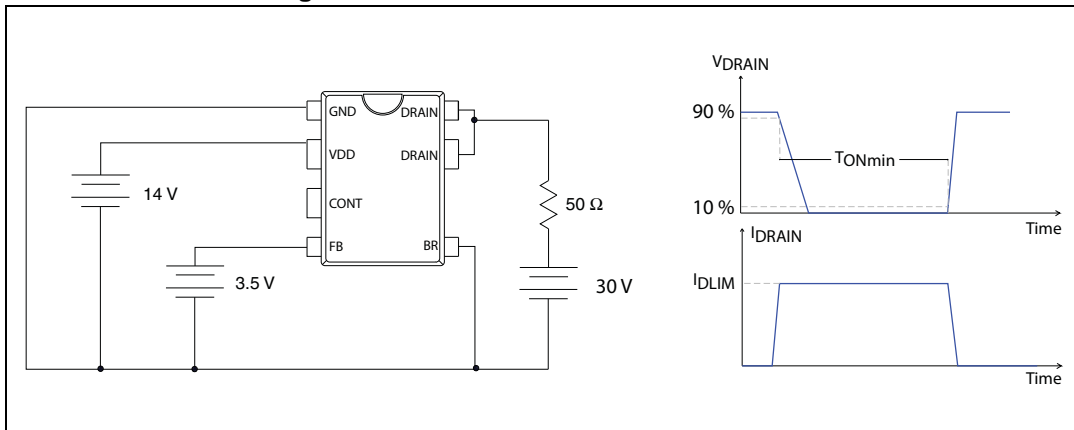

Figure 5. Brown out threshold test circuit

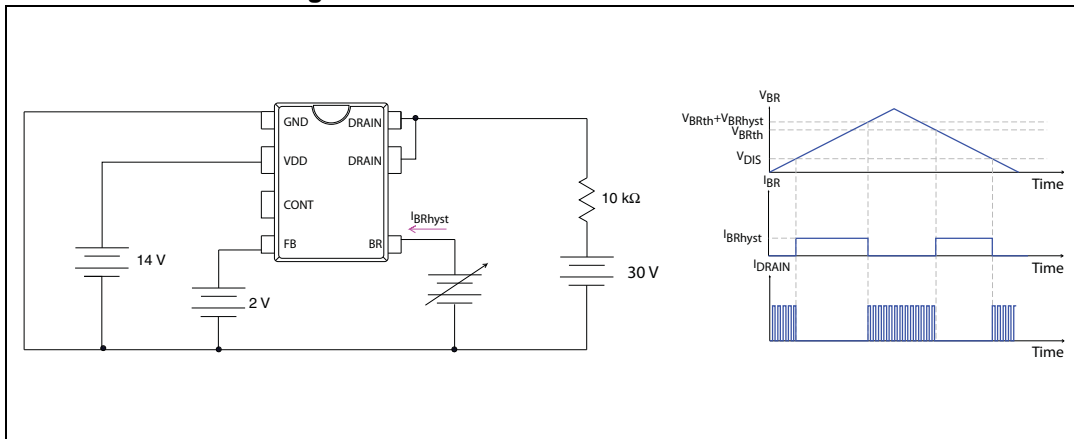
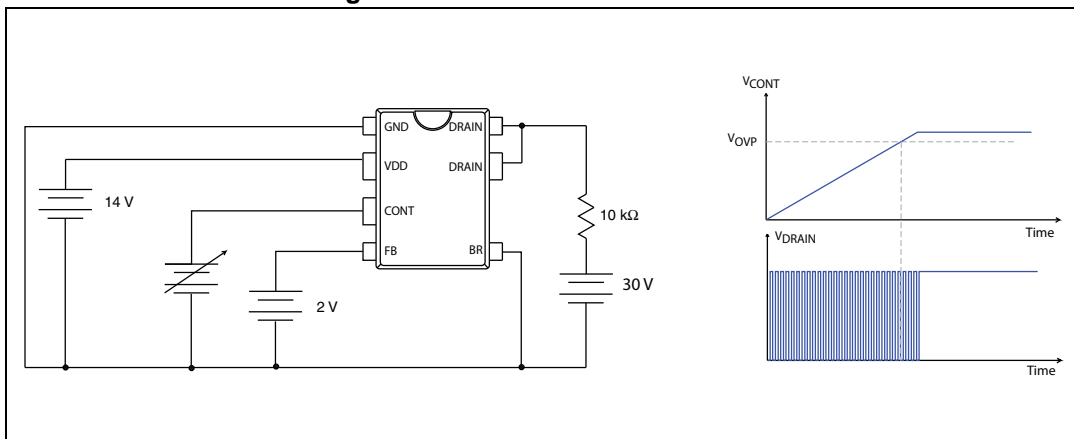

Figure 6. OVP threshold test circuit



Note: Adjust V_{DD} above V_{DDon} start-up threshold before settings to 14 V

5 Typical electrical characteristics

Figure 7. Current limit vs T_J

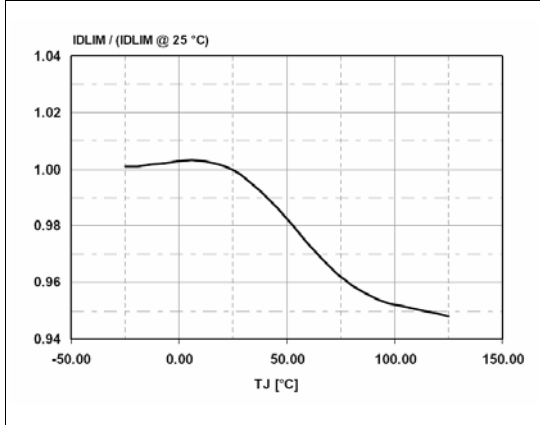

Figure 8. Switching frequency vs T_J

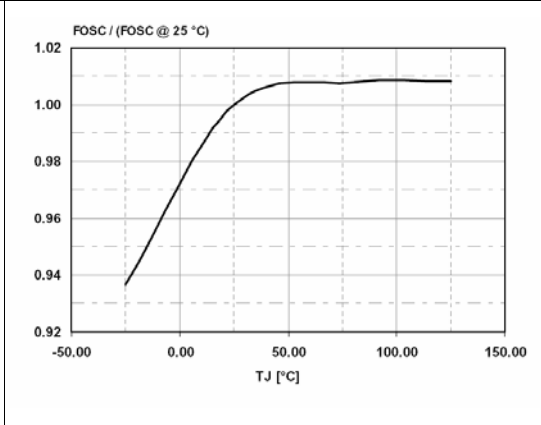

Figure 9. Drain start voltage vs T_J

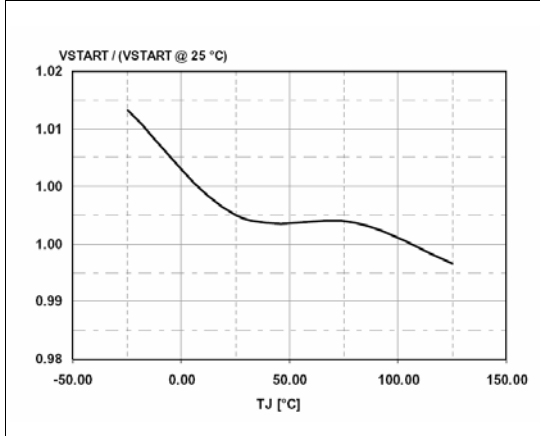

Figure 10. HFB vs T_J

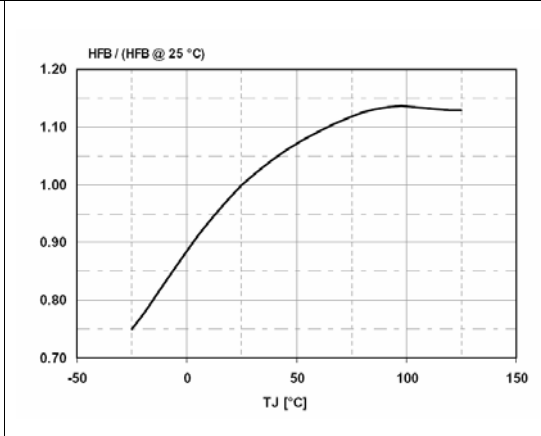

Figure 11. Brown out threshold vs T_J

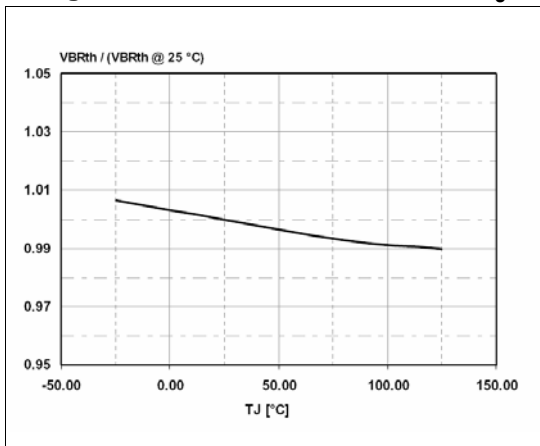

Figure 12. Brown out hysteresis vs T_J

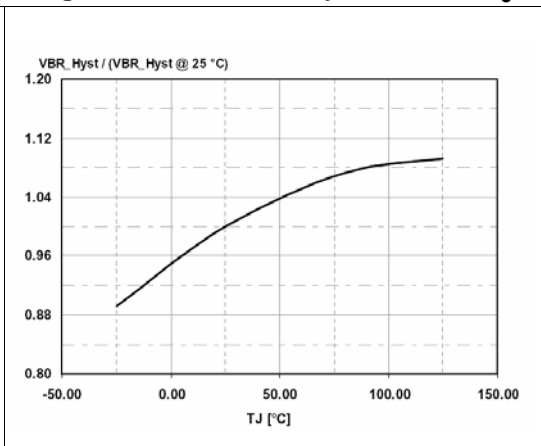

Figure 13. Brown out hysteresis current vs T_J

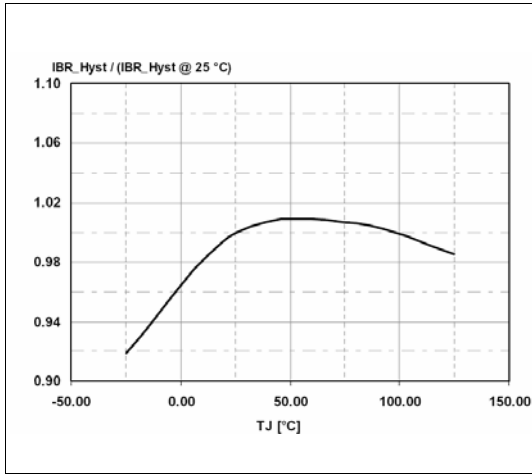

Figure 14. Operating supply current (no switching) vs T_J

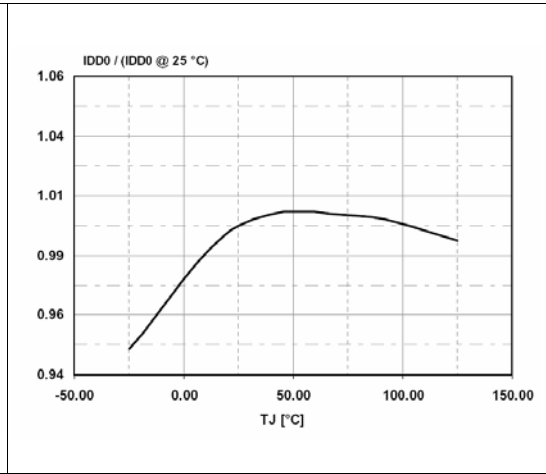

Figure 15. Operating supply current (switching) vs T_J

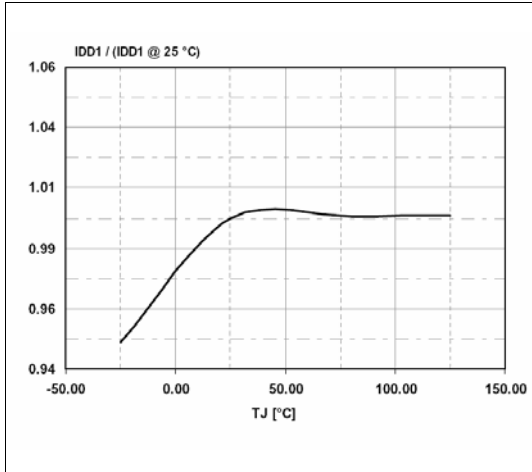

Figure 16. current limit vs R_{LIM}

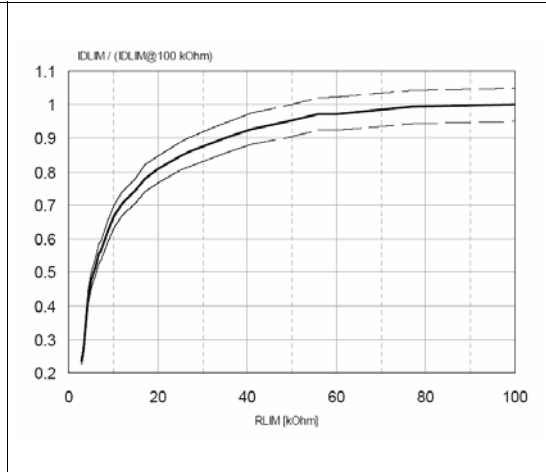

Figure 17. Power MOSFET on-resistance vs T_J

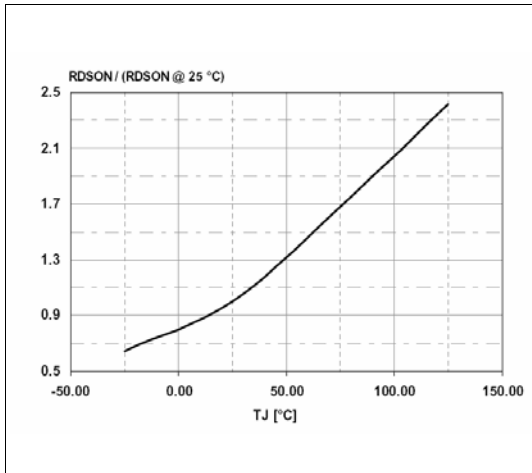

Figure 18. Power MOSFET break down voltage vs T_J

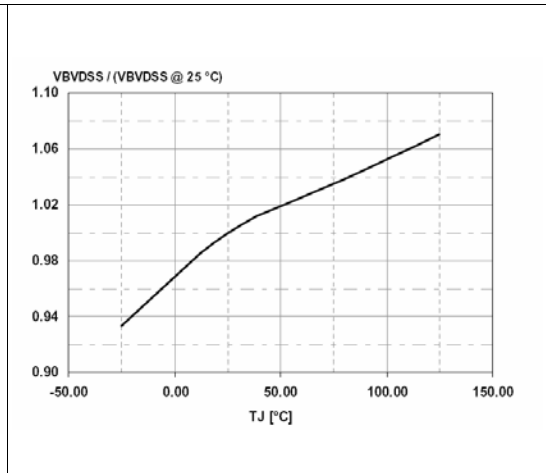
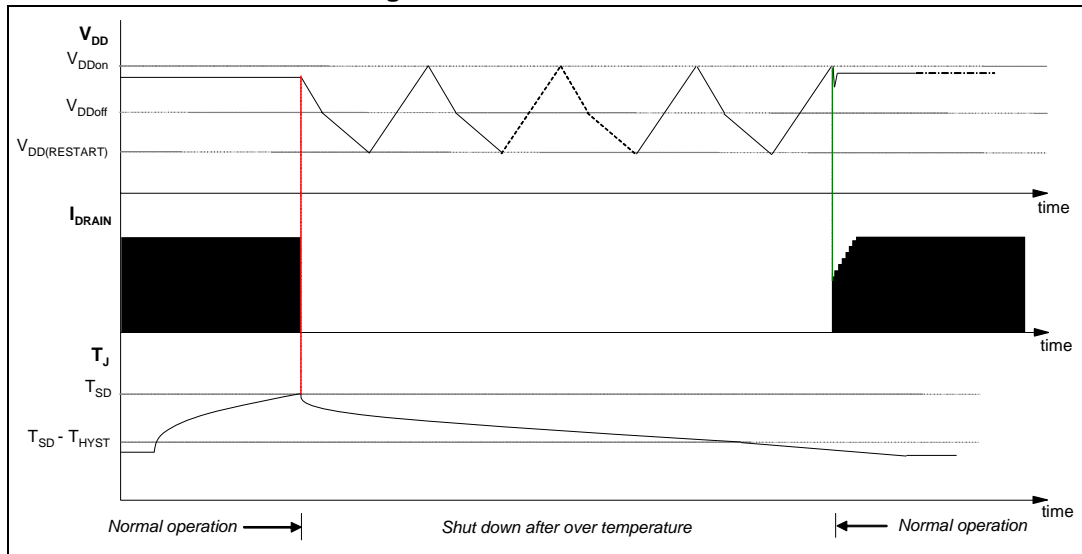

Figure 19. Thermal shutdown



6 Typical circuit

Figure 20. Min-features flyback application

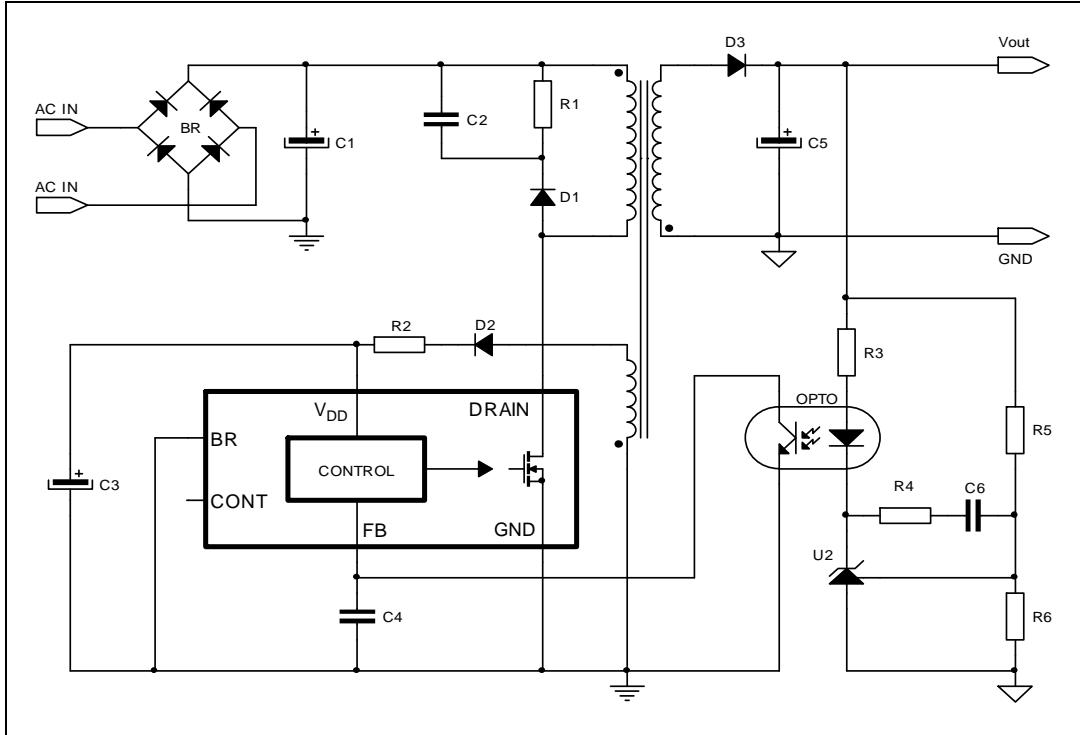
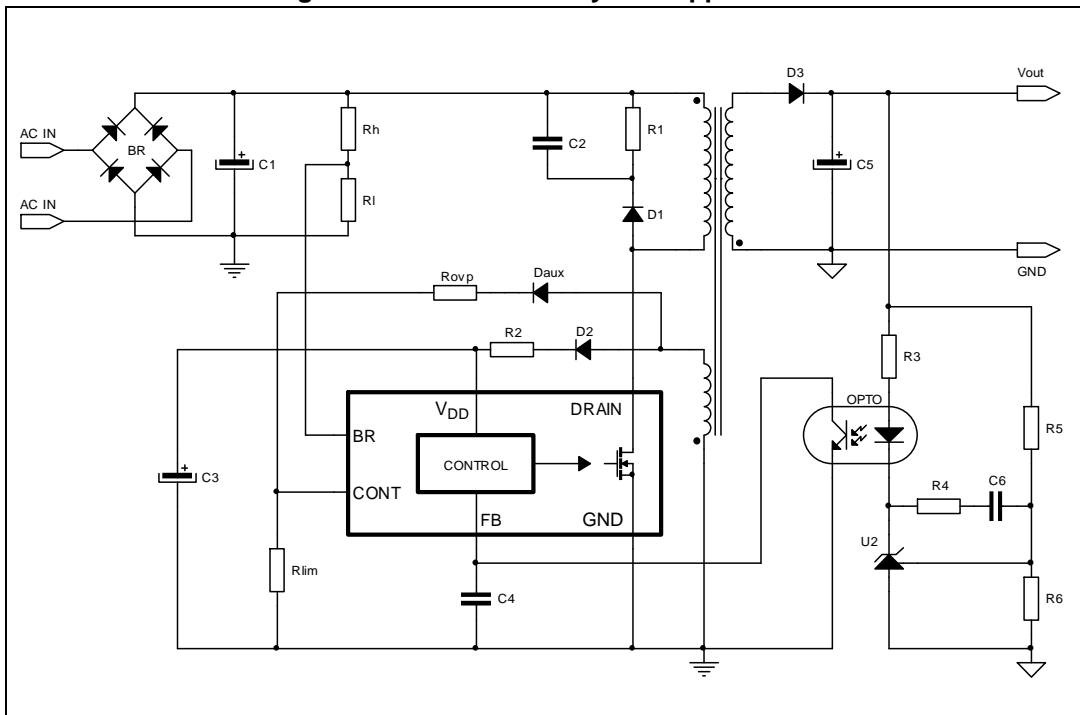

Figure 21. Full-features flyback application



7 Operation descriptions

VIPER17 is a high-performance low-voltage PWM controller chip with an 800 V, avalanche rugged power section.

The controller includes: the oscillator with jittering feature, the start up circuits with soft-start feature, the PWM logic, the current limit circuit with adjustable set point, the second over current circuit, the burst mode management, the brown-out circuit, the UVLO circuit, the auto-restart circuit and the thermal protection circuit.

The current limit set-point is set by the CONT pin. The burst mode operation guarantees high performance in the stand-by mode and helps in the energy saving norm accomplishment.

All the fault protections are built in auto restart mode with very low repetition rate to prevent IC's over heating.

7.1 Power section and gate driver

The power section is implemented with an avalanche ruggedness N-channel MOSFET, which guarantees safe operation within the specified energy rating as well as high dv/dt capability. The power section has a BV_{DSS} of 800 V min. and a typical $R_{DS(on)}$ of 20 Ω at 25 °C.

The integrated SenseFET structure allows a virtually loss-less current sensing.

The gate driver is designed to supply a controlled gate current during both turn-on and turn-off in order to minimize common mode EMI. Under UVLO conditions an internal pull-down circuit holds the gate low in order to ensure that the Power section cannot be turned on accidentally.

7.2 High voltage startup generator

The HV current generator is supplied through the DRAIN pin and it is enabled only if the input bulk capacitor voltage is higher than V_{DRAIN_START} threshold, 80 V_{DC} typically. When the HV current generator is ON, the I_{DDch} current (3 mA typical value) is delivered to the capacitor on the V_{DD} pin. In case of auto restart mode after a fault event, the I_{DDch} current is reduced to 0.6 mA, in order to have a slow duty cycle during the restart phase.

7.3 Power-up and soft-start up

If the input voltage rises up till the device start threshold, V_{DRAIN_START} , the V_{DD} voltage begins to grow due to the I_{DDch} current (see [Table 7 on page 7](#)) coming from the internal high voltage start up circuit. If the V_{DD} voltage reaches V_{DDon} threshold (see [Table 7 on page 7](#)) the power MOSFET starts switching and the HV current generator is turned OFF. See [Figure 23 on page 17](#).

The IC is powered by the energy stored in the capacitor on the V_{DD} pin, C_{VDD} , until when the self-supply circuit (typically an auxiliary winding of the transformer and a steering diode) develops a voltage high enough to sustain the operation.

C_{VDD} capacitor must be sized enough to avoid fast discharge and keep the needed voltage value higher than V_{DDoff} threshold. In fact, a too low capacitance value could terminate the switching operation before the controller receives any energy from the auxiliary winding.

The following formula can be used for the V_{DD} capacitor calculation:

Equation 1

$$C_{VDD} = \frac{I_{DDch} \times t_{SSaux}}{V_{DDon} - V_{DDoff}}$$

The t_{SSaux} is the time needed for the steady state of the auxiliary voltage. This time is estimated by applicator according to the output stage configurations (transformer, output capacitances, etc.).

During the converter start up time, the drain current limitation is progressively increased to the maximum value. In this way the stress on the secondary diode is considerably reduced. It also helps to prevent transformer saturation. The soft-start time lasts 8.5 ms and the feature is implemented for every attempt of start up converter or after a fault.

Figure 22. I_{DD} current during start-up and burst mode

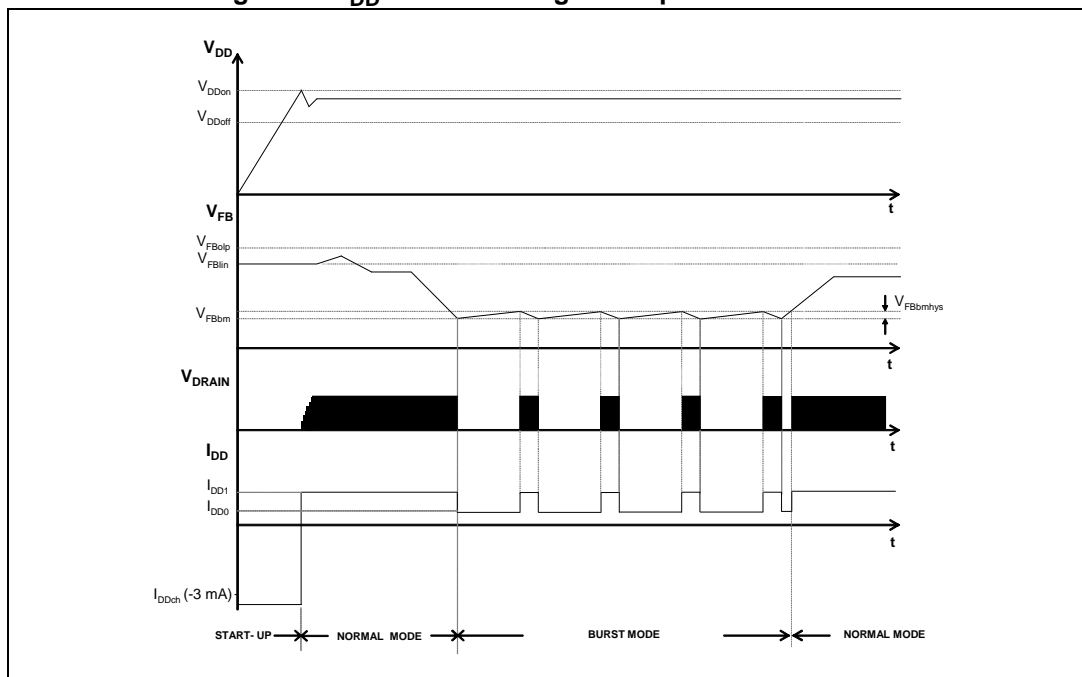

Figure 23. Timing diagram: normal power-up and power-down sequences

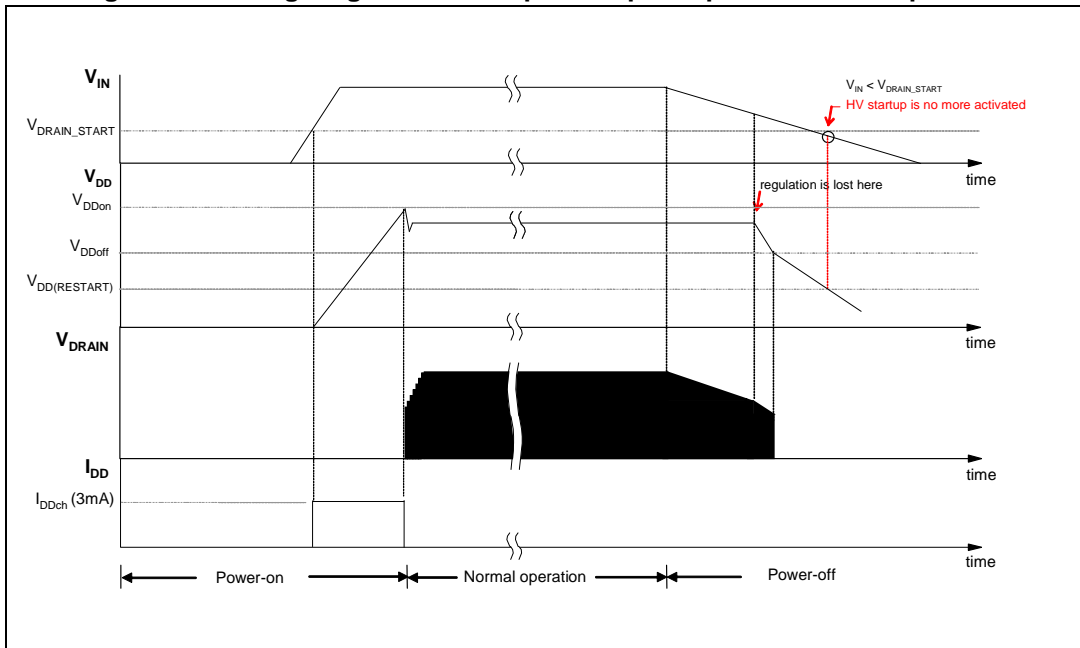
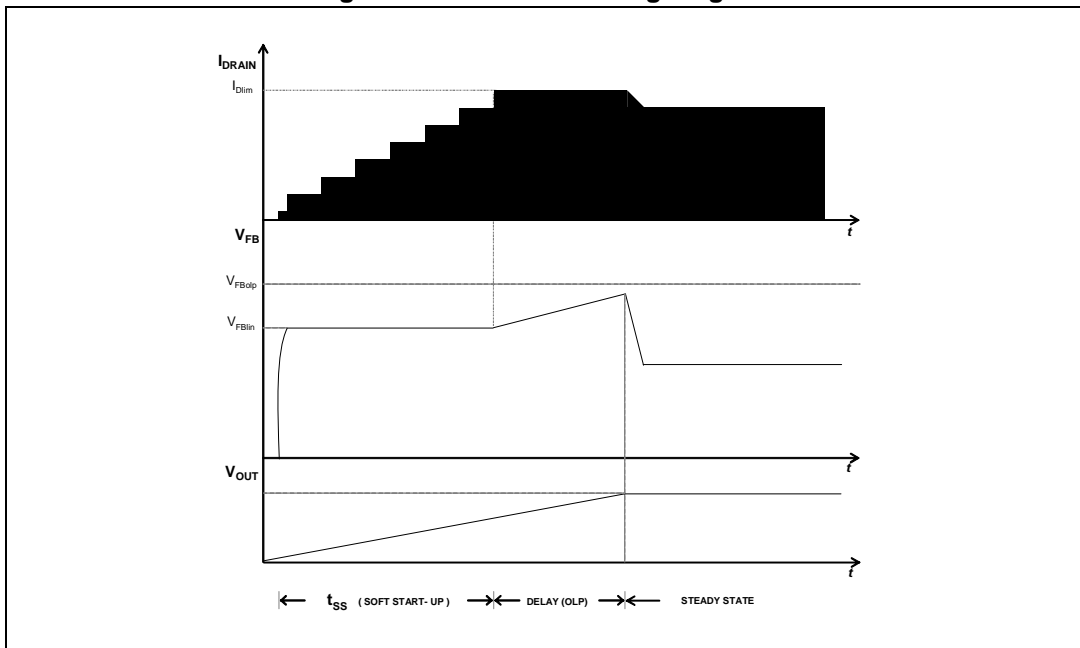

Figure 24. Soft-start: timing diagram



7.4 Power down operation

At converter power down, the system loses regulation as soon as the input voltage is so low that the peak current limitation is reached. The V_{DD} voltage drops and when it falls below the V_{DDoff} threshold (see [Table 7 on page 7](#)) the power MOSFET is switched OFF, the energy transfers to the IC interrupted and consequently the V_{DD} voltages decreases, [Figure 23 on page 17](#). Later, if the V_{IN} is lower than V_{DRAIN_START} (see [Table 7 on page 7](#)), the start up sequence is inhibited and the power down completed. This feature is useful to prevent converter's restart attempts and ensures monotonic output voltage decay during the system power down.

7.5 Auto restart operation

If after a converter power down, the V_{IN} is higher than V_{DRAIN_START} , the start up sequence is not inhibited and will be activated only when the V_{DD} voltage drops down the $V_{DD(RESTART)}$ threshold (see [Table 7 on page 7](#)). This means that the HV start up current generator restarts the V_{DD} capacitor charging only when the V_{DD} voltage drops below $V_{DD(RESTART)}$. The scenario above described is for instance a power down because of a fault condition. After a fault condition, the charging current, I_{DDch} , is 0.6 mA (typ.) instead of the 3 mA (typ.) of a normal start up converter phase. This feature together with the low $V_{DD(RESTART)}$ threshold ensures that, after a fault, the restart attempts of the IC has a very long repetition rate and the converter works safely with extremely low power throughput. The [Figure 25](#) shows the IC behavioral after a short circuit event.

Figure 25. Timing diagram: behavior after short circuit

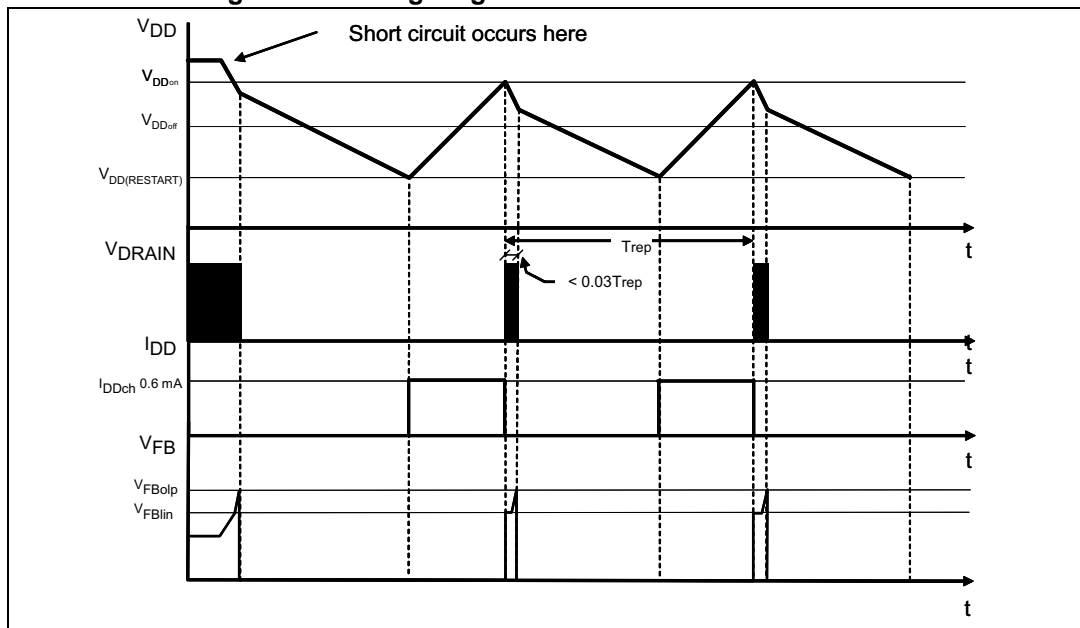

7.6 Oscillator

The switching frequency is internally fixed to 60 kHz or 115 kHz. In both case the switching frequency is modulated by approximately ± 4 kHz (60 kHz version) or ± 8 kHz (115 kHz version) at 250 Hz (typical) rate, so that the resulting spread-spectrum action distributes the energy of each harmonic of the switching frequency over a number of side-band harmonics having the same energy on the whole but smaller amplitudes.

7.7 Current mode conversion with adjustable current limit set point

The device is a current mode converter: the drain current is sensed and converted in voltage that is applied to the non inverting pin of the PWM comparator. This voltage is compared with the one on the feed-back pin through a voltage divider on cycle by cycle basis.

The VIPER17 has a default current limit value, I_{DLIM} , that the designer can adjust according the electrical specification, by the R_{LIM} resistor connected to the CONT see [Figure 16 on page 12](#).

The CONT pin has a minimum current sunk needed to activate the I_{DLIM} adjustment: without R_{LIM} or with high R_{LIM} (i.e. 100 K Ω) the current limit is fixed to the default value (see I_{DLIM} , [Table 8 on page 8](#)).

7.8 Overvoltage protection (OVP)

The VIPER17 has integrated the logic for the monitor of the output voltage using as input signal the voltage V_{CONT} during the OFF time of the power MOSFET. This is the time when the voltage from the auxiliary winding tracks the output voltage, through the turn ratio $\frac{N_{AUX}}{N_{SEC}}$

The CONT pin has to be connected to the auxiliary winding through the diode D_{OVP} and the resistors R_{OVP} and R_{LIM} as shows the [Figure 27 on page 21](#). When, during the OFF time, the voltage V_{CONT} exceeds, four consecutive times, the reference voltage V_{OVP} (see [Table 8 on page 8](#)) the overvoltage protection will stop the power MOSFET and the converter enters the auto-restart mode.

In order to bypass the noise immediately after the turn off of the power MOSFET, the voltage V_{CONT} is sampled inside a short window after the time T_{STROBE} , see [Table 8 on page 8](#) and the [Figure 26 on page 21](#). The sampled signal, if higher than V_{OVP} , trigger the internal OVP digital signal and increments the internal counter. The same counter is reset every time the signal OVP is not triggered in one oscillator cycle.

Referring to the [Figure 21](#), the resistors divider ratio k_{OVP} will be given by:

Equation 2

$$k_{OVP} = \frac{V_{OVP}}{\frac{N_{AUX}}{N_{SEC}} \cdot (V_{OUTOVP} + V_{DSEC}) - V_{DAUX}}$$

Equation 3

$$k_{OVP} = \frac{R_{LIM}}{R_{LIM} + R_{OVP}}$$

Where:

- V_{OVP} is the OVP threshold (see [Table 9 on page 8](#))
- V_{OUTOVP} is the converter output voltage value to activate the OVP (set by designer)
- N_{AUX} is the auxiliary winding turns
- N_{SEC} is the secondary winding turns
- V_{DSEC} is the secondary diode forward voltage
- V_{DAUX} is the auxiliary diode forward voltage
- R_{OVP} together R_{LIM} make the output voltage divider

Then, fixed R_{LIM} , according to the desired I_{DLIM} , the R_{OVP} can be calculating by:

Equation 4

$$R_{OVP} = R_{LIM} \times \frac{1 - k_{OVP}}{k_{OVP}}$$

The resistor values will be such that the current sourced and sunk by the CONT pin be within the rated capability of the internal clamp.

Figure 26. OVP timing diagram

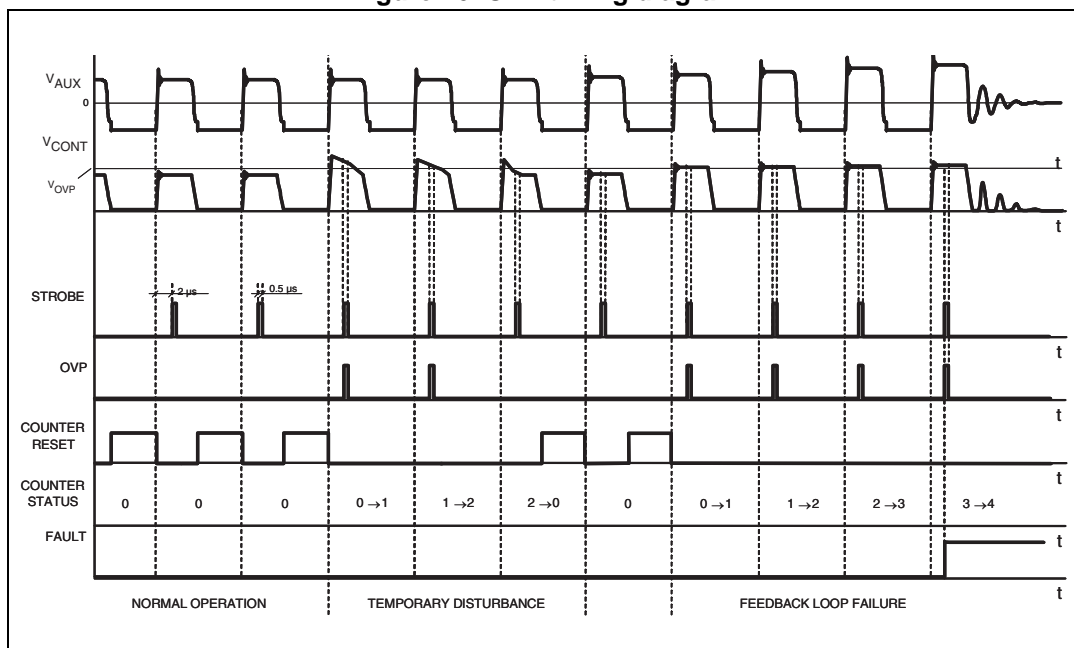

7.9 About CONT pin

Referring to the [Figure 27](#), through the CONT pin, the below features can be implemented:

1. Current Limit set point
2. Over voltage protection on the converter output voltage

The [Table 9 on page 22](#) referring to the [Figure 27](#), lists the external components needed to activate one or plus of the CONT pin functions.

Figure 27. CONT pin configuration

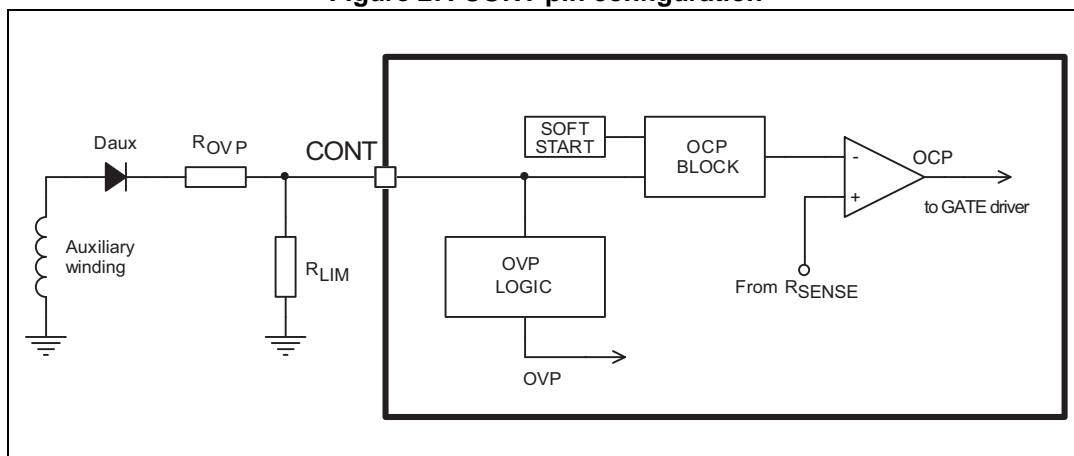

Table 9. CONT pin configurations

Function / component	R _{LIM} ⁽¹⁾	R _{OVP}	D _{AUX}
I _{Dlim} reduction	See Figure 16	No	No
OVP	≥ 80 KΩ	See Equation 4	Yes
I _{Dlim} reduction + OVP	See Figure 16	See Equation 4	Yes

1. R_{LIM} has to be fixed before of R_{OVP}

7.10 Feed-back and overload protection (OLP)

The VIPER17 is a current mode converter: the feedback pin controls the PWM operation, controls the burst mode and activates the overload protection. [Figure 28 on page 24](#) and [Figure 29](#) show the internal current mode structure.

With the feedback pin voltage between V_{FBbm} and V_{FBlin}, see [Table 8 on page 8](#), the drain current is sensed and converted in voltage that is applied to the non inverting pin of the PWM comparator. See [Figure 2 on page 3](#).

This voltage is compared with the one on the feedback pin through a voltage divider on cycle by cycle basis. When these two voltages are equal, the PWM logic orders the switch off of the power MOSFET. The drain current is always limited to I_{Dlim} value.

In case of overload the feedback pin increases in reaction to this event and when it goes higher than V_{FBlin}, the PWM comparator is disabled and the drain current is limited to I_{Dlim} by the OCP comparator, see [Figure 2 on page 3](#).

When the feedback pin voltage reaches the threshold V_{FBlin} an internal current generator starts to charge the feedback capacitor (C_{FB}) and when the feedback voltage reaches the V_{FBolp} threshold, the converter is turned off and the start up phase is activated with reduced value of I_{DDch} to 0.6 mA. See [Table 7 on page 7](#).

During the first start up phase of the converter, after the soft-start up time, t_{SS}, the output voltage could force the feedback pin voltage to rise up to the V_{FBolp} threshold that switches off the converter itself.

To avoid this event, the appropriate feedback network has to be selected according to the output load. More the network feedback fixes the compensation loop stability. The [Figure 28 on page 24](#) and [Figure 29](#) show the two different feedback networks.

The time from the over load detection (V_{FB} = V_{FBlin}) to the device shutdown (V_{FB} = V_{FBolp}) can be calculating by C_{FB} value (see [Figure 28 on page 24](#) and [Figure 29](#)), using the formula:

Equation 5

$$T_{\text{OLP-delay}} = C_{\text{FB}} \times \frac{V_{\text{FBolp}} - V_{\text{FBlin}}}{3\mu\text{A}}$$

In the [Figure 28](#), the capacitor connected to FB pin (C_{FB}) is used as part of the circuit to compensate the feedback loop but also as element to delay the OLP shut down owing to the time needed to charge the capacitor (see equation 5).

After the start up time, t_{SS} , during which the feedback voltage is fixed at V_{FBlin} , the output capacitor could not be at its nominal value and the controller interpreter this situation as an over load condition. In this case, the OLP delay helps to avoid an incorrect device shut down during the start up.

Owing to the above considerations, the OLP delay time must be long enough to by-pass the initial output voltage transient and check the over load condition only when the output voltage is in steady state. The output transient time depends from the value of the output capacitor and from the load.

When the value of the C_{FB} capacitor calculated for the loop stability is too low and cannot ensure enough OLP delay, an alternative compensation network can be used and it is showed in [Figure 29 on page 24](#).

Using this alternative compensation network, two poles (f_{PFB} , f_{PFB1}) and one zero (f_{ZFB}) are introduced by the capacitors C_{FB} and C_{FB1} and the resistor R_{FB1} .

The capacitor C_{FB} introduces a pole (f_{PFB}) at higher frequency than f_{ZB} and f_{PFB1} . This pole is usually used to compensate the high frequency zero due to the ESR (Equivalent Series Resistor) of the output capacitance of the fly-back converter.

The mathematical expressions of these poles and zero frequency, considering the scheme in [Figure 29](#) are reported by the equations below:

Equation 6

$$f_{ZFB} = \frac{1}{2 \cdot \pi \cdot C_{FB1} \cdot R_{FB1}}$$

Equation 7

$$f_{PFB} = \frac{R_{FB(DYN)} + R_{FB1}}{2 \cdot \pi \cdot C_{FB} \cdot (R_{FB(DYN)} \cdot R_{FB1})}$$

Equation 8

$$f_{PFB1} = \frac{1}{2 \cdot \pi \cdot C_{FB1} \cdot (R_{FB1} + R_{FB(DYN)})}$$

The $R_{FB(DYN)}$ is the dynamic resistance seen by the FB pin.

The C_{FB1} capacitor fixes the OLP delay and usually C_{FB1} results much higher than C_{FB} . The [Equation 5](#) can be still used to calculate the OLP delay time but C_{FB1} has to be considered instead of C_{FB} . Using the alternative compensation network, the designer can satisfy, in all case, the loop stability and the enough OLP delay time alike.

Figure 28. FB pin configuration

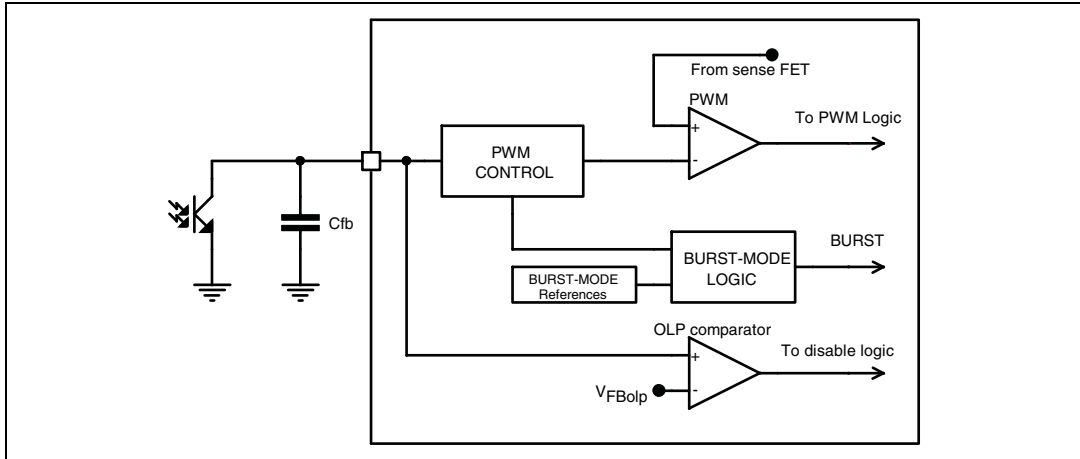
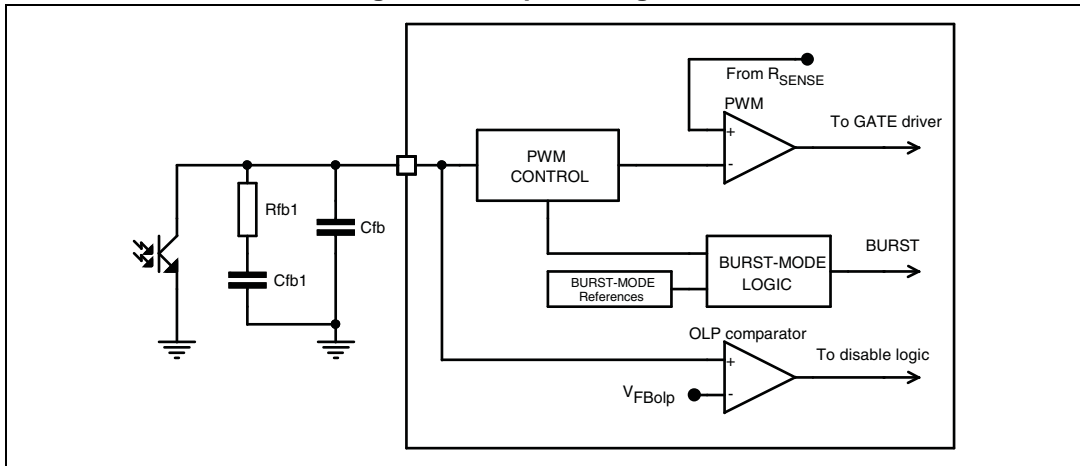

Figure 29. FB pin configuration



7.11 Burst-mode operation at no load or very light load

When the load decrease the feedback loop reacts lowering the feedback pin voltage. If it falls down the burst mode threshold, V_{FBbm} , the power MOSFET is not more allowed to be switched on. After the MOSFET stops, as a result of the feedback reaction to the energy delivery stop, the feedback pin voltage increases and exceeding the level, $V_{FBbm} + V_{FBbmhys}$, the power MOSFET starts switching again. The burst mode thresholds are reported on [Table 8](#) and [Figure 30](#) shows this behavior. Systems alternates period of time where power MOSFET is switching to period of time where power MOSFET is not switching; this device working mode is the burst mode. The power delivered to output during switching periods exceeds the load power demands; the excess of power is balanced from not switching period where no power is processed. The advantage of burst mode operation is an average switching frequency much lower then the normal operation working frequency, up to some hundred of hertz, minimizing all frequency related losses. During the burst-mode the drain current peak is clamped to the level, I_{D_BM} , reported on [Table 8](#).

Figure 30. Burst mode timing diagram, light load management

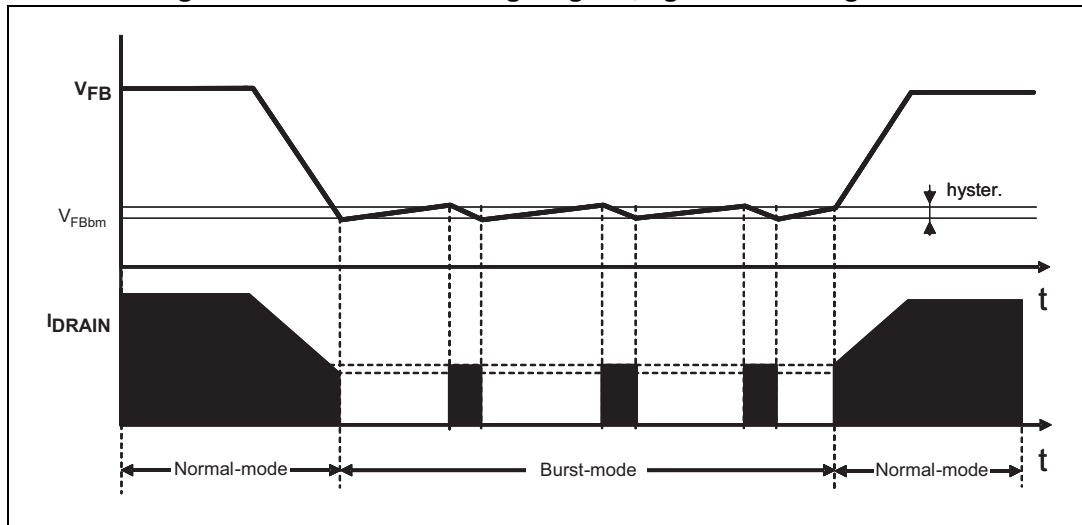

7.12 Brown-out protection

Brown-out protection is a not-latched shutdown function activated when a condition of mains under voltage is detected. The Brown-out comparator is internally referenced to V_{BRth} threshold, see [Table 8 on page 8](#), and disables the PWM if the voltage applied at the BR pin is below this internal reference. Under this condition the power MOSFET is turned off. Until the Brown out condition is present, the V_{DD} voltage continuously oscillates between the V_{DDon} and the UVLO thresholds, as shown in the timing diagram of [Figure 31 on page 26](#). A voltage hysteresis is present to improve the noise immunity.

The switching operation is restarted as the voltage on the pin is above the reference plus the before said voltage hysteresis. See [Figure 5 on page 10](#).

The Brown-out comparator is provided also with a current hysteresis, I_{BRhyst} . The designer has to set the rectified input voltage above which the power MOSFET starts switching after brown out event, V_{INon} , and the rectified input voltage below which the power MOSFET is switched off, V_{INoff} . Thanks to the I_{BRhyst} , see [Table 8 on page 8](#), these two thresholds can be set separately.

Figure 31. Brown-out protection: BR external setting and timing diagram

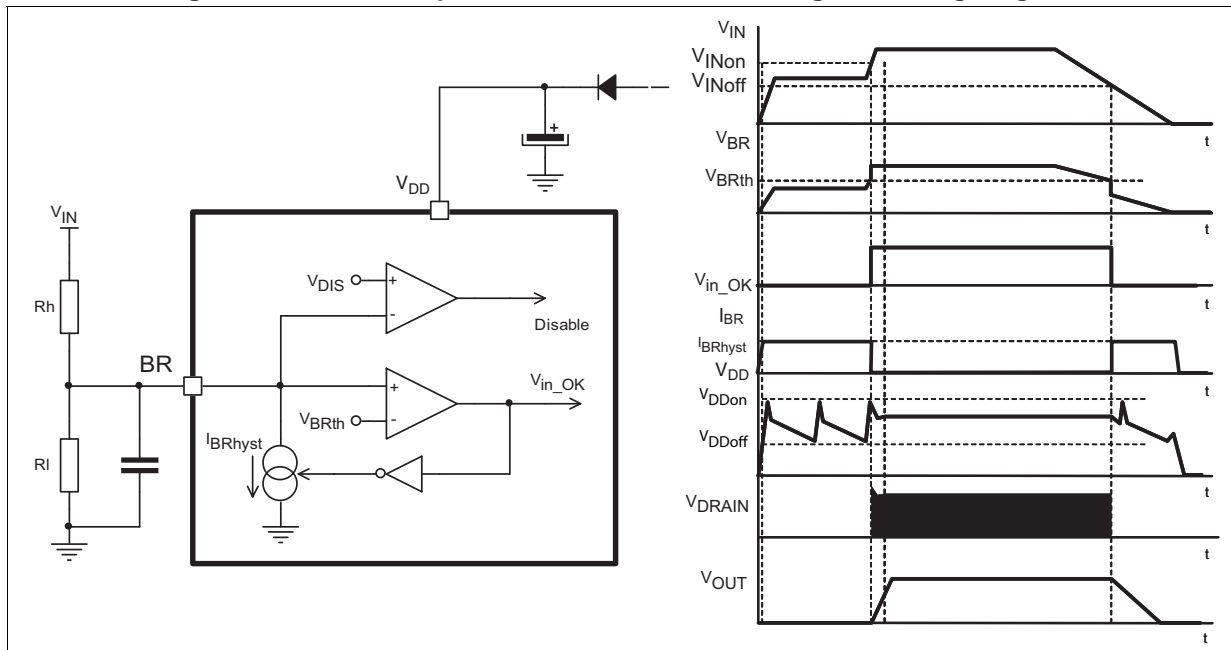

Fixed the V_{INon} and the V_{INoff} levels, with reference to [Figure 31](#), the following relationships can be established for the calculation of the resistors R_H and R_L :

Equation 9

$$R_L = -\frac{V_{BRhyst}}{I_{BRhyst}} + \frac{V_{INon} - V_{INoff} - V_{BRhyst}}{V_{INoff} - V_{BRth}} \times \frac{V_{BRth}}{I_{BRhyst}}$$

Equation 10

$$R_H = \frac{V_{INon} - V_{INoff} - V_{BRhyst}}{I_{BRhyst}} \times \frac{R_L}{R_L + \frac{V_{BRhyst}}{I_{BRhyst}}}$$

For a proper operation of this function, V_{INon} must be less than the peak voltage at minimum mains and V_{INoff} less than the minimum voltage on the input bulk capacitor at minimum mains and maximum load.

The BR pin is a high impedance input connected to high value resistors, thus it is prone to pick up noise, which might alter the OFF threshold when the converter operates or gives origin to undesired switch-off of the device during ESD tests.

It is possible to bypass the pin to ground with a small film capacitor (e.g. 1-10 nF) to prevent any malfunctioning of this kind.

If the brown-out function is not used the BR pin has to be connected to GND, ensuring that the voltage is lower than the minimum of V_{DIS} threshold (50 mV, see [Table 8](#)). In order to enable the brown-out function the BR pin voltage has to be higher than the maximum of V_{DIS} threshold (150 mV, see [Table 8](#)).

7.13 2nd level overcurrent protection and hiccup mode

The VIPER17 is protected against short circuit of the secondary rectifier, short circuit on the secondary winding or a hard-saturation of fly-back transformer. Such as anomalous condition is invoked when the drain current exceed the threshold $I_{D\text{MAX}}$ (see [Table 8 on page 8](#)).

To distinguish a real malfunction from a disturbance (e.g. induced during ESD tests) a “warning state” is entered after the first signal trip. If in the subsequent switching cycle the signal is not tripped, a temporary disturbance is assumed and the protection logic will be reset in its idle state; otherwise if the $I_{D\text{MAX}}$ threshold is exceeded for two consecutive switching cycles a real malfunction is assumed and the power MOSFET is turned OFF.

The shutdown condition is latched as long as the device is supplied. While it is disabled, no energy is transferred from the auxiliary winding; hence the voltage on the V_{DD} capacitor decays till the V_{DD} under voltage threshold ($V_{DD\text{off}}$), which clears the latch.

The start up HV current generator is still off, until V_{DD} voltage goes below its restart voltage, $V_{DD(\text{RESTART})}$. After this condition the V_{DD} capacitor is charged again by 600 μA current, and the converter switching restarts if the $V_{DD\text{on}}$ occurs. If the fault condition is not removed the device enters in auto-restart mode. This behavioral results in a low-frequency intermittent operation (Hiccup-mode operation), with very low stress on the power circuit. See the timing diagram of [Figure 32](#).

Figure 32. Hiccup-mode OCP: timing diagram

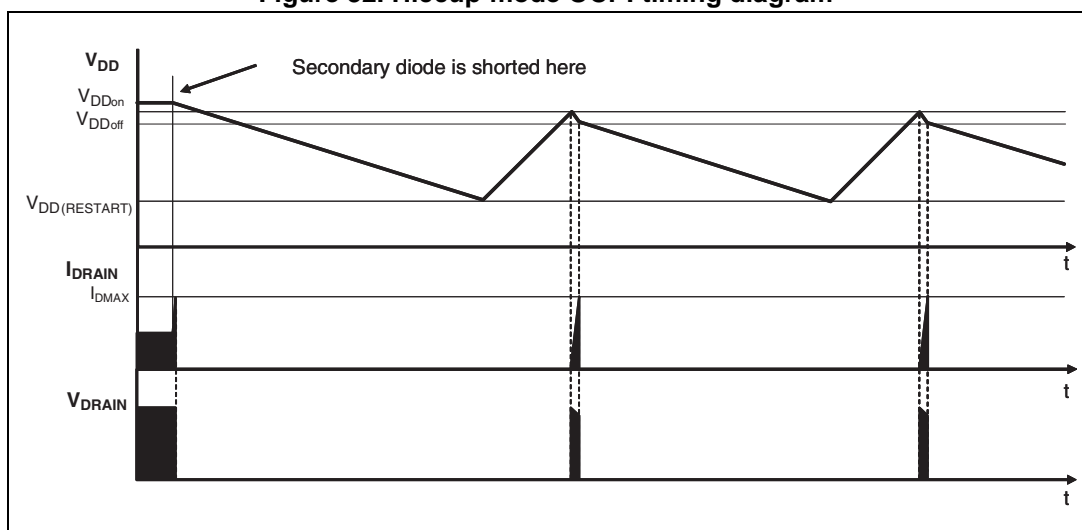

8 Package mechanical data

In order to meet environmental requirements, ST offers these devices in different grades of ECOPACK[®] packages, depending on their level of environmental compliance. ECOPACK[®] specifications, grade definitions and product status are available at: www.st.com. ECOPACK[®] is an ST trademark.

Figure 33. DIP-7 drawing

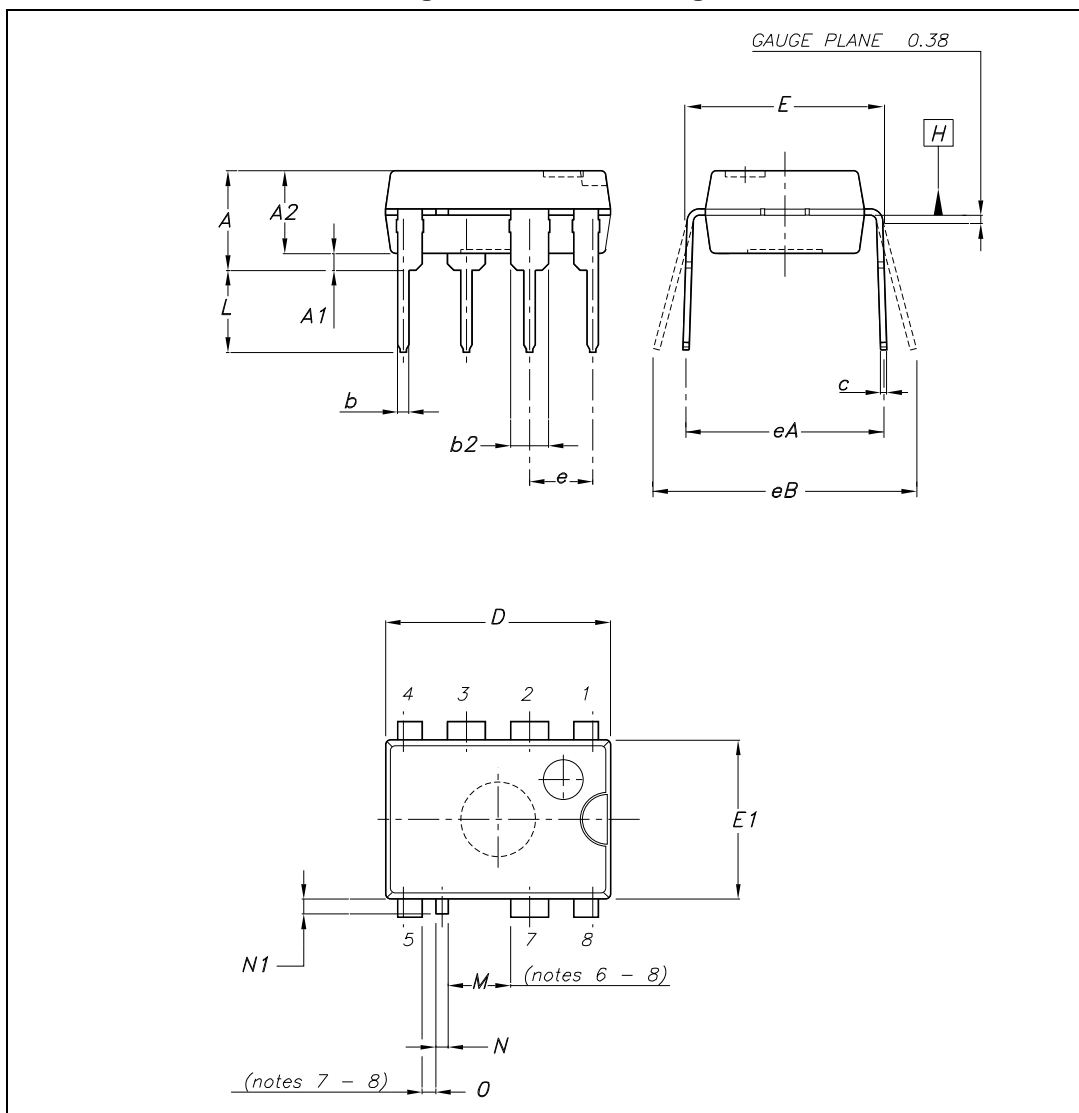

Table 10. DIP-7 mechanical data

Dim.	mm		
	Typ	Min	Max
A			5,33
A1		0,38	
A2	3,30	2,92	4,95
b	0,46	0,36	0,56
b2	1,52	1,14	1,78
c	0,25	0,20	0,36
D	9,27	9,02	10,16
E	7,87	7,62	8,26
E1	6,35	6,10	7,11
e	2,54		
eA	7,62		
eB			10,92
L	3,30	2,92	3,81
M ⁽⁶⁾⁽⁸⁾	2,508		
N	0,50	0,40	0,60
N1			0,60
O ⁽⁷⁾⁽⁸⁾	0,548		

- 1- The leads size is comprehensive of the thickness of the leads finishing material.
- 2- Dimensions do not include mold protrusion, not to exceed 0,25 mm in total (both side).
- 3- Package outline exclusive of metal burrs dimensions.
- 4- Datum plane "H" coincident with the bottom of lead, where lead exits body.
- 5- Ref. POA MOTHER doc. 0037880
- 6- Creepage distance > 800 V
- 7- Creepage distance 250 V
- 8- Creepage distance as shown in the 664-1 CEI / IEC standard.

Figure 34. SO16 Narrow drawing

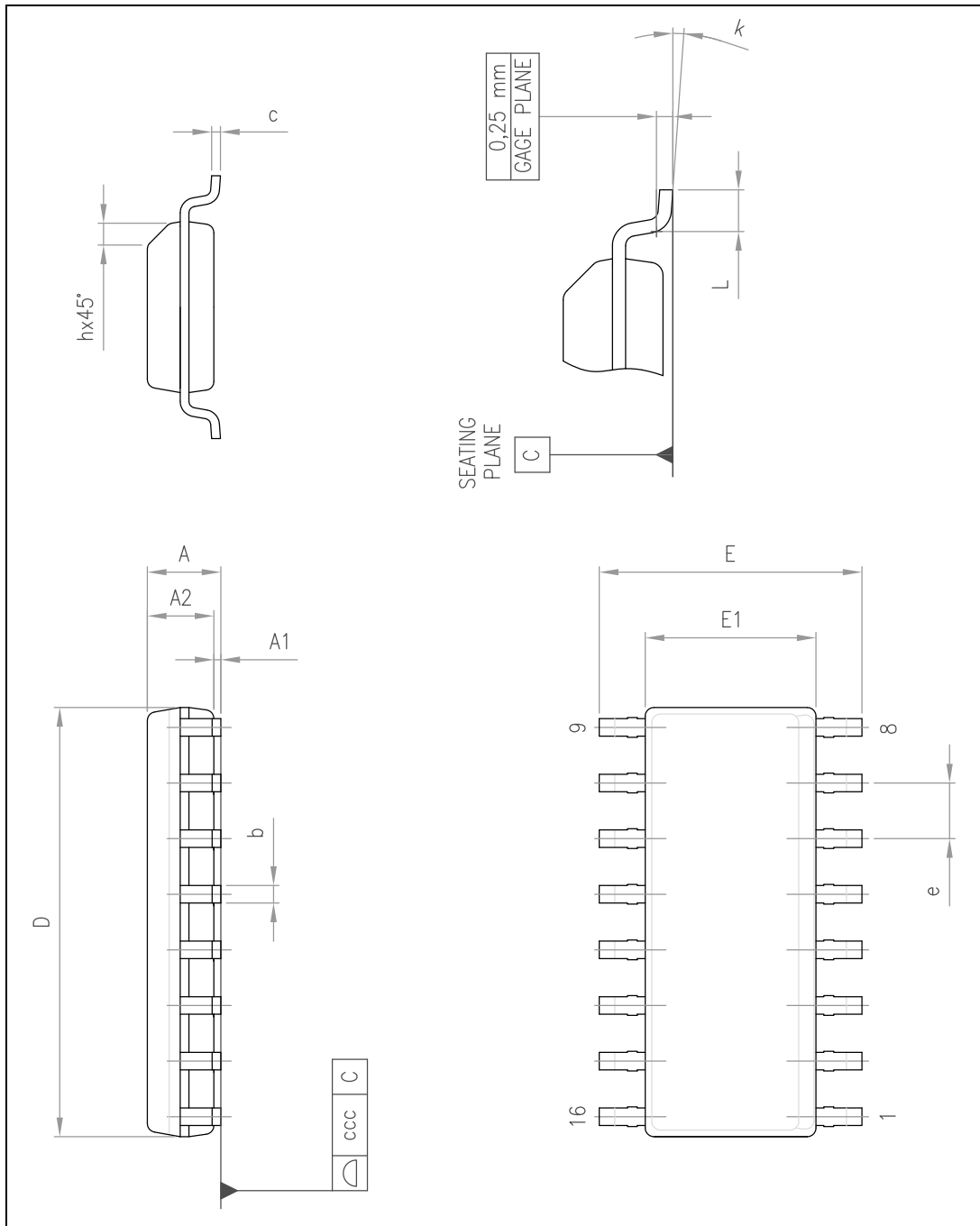

Table 11. SO16 Narrow mechanical data

Dimensions			
Ref.	Databook (mm.)		
	Min	Typ.	Max
A			1.75
A1	0.1		0.25
A2	1.25		
b	0.31		0.51
c	0.17		0.25
D	9.8	9.9	10
E	5.8	6	6.2
E1	3.8	3.9	4
e		1.27	
h	0.25		0.5
L	0.4		1.27
k	0		8
ccc			0.1

9 Revision history

Table 12. Document revision history

Date	Revision	Changes
14-Feb-2008	1	Initial release
19-Feb-2008	2	Updated: <i>Figure 1 on page 1, Figure 3 on page 4</i>
21-Jul-2008	3	Added new SO16 package
30-Sep-2008	4	Updated <i>Equation 9, Equation 10</i>
16-Jan-2009	5	Updated <i>Chapter 7.13 on page 27</i>
20-Jul-2009	6	Updated application paragraph in coverpage and <i>Table 8 on page 8</i>
14-Jun-2010	7	Updated <i>Figure 3 on page 4</i> and <i>Table 3 on page 4</i>
23-Jul-2013	8	Updated <i>Table 8: Controller section</i> . Minor text changes.
30-Aug-2013	9	Modified the footnote in <i>Table 8: Controller section</i> .
20-May-2014	10	Modified the title and the features in cover page. Updated <i>Section 3: Pin settings, Section 4.1: Maximum ratings, Section 4.3: Electrical characteristics</i> . Minor text changes.

Please Read Carefully:

Information in this document is provided solely in connection with ST products. STMicroelectronics NV and its subsidiaries ("ST") reserve the right to make changes, corrections, modifications or improvements, to this document, and the products and services described herein at any time, without notice.

All ST products are sold pursuant to ST's terms and conditions of sale.

Purchasers are solely responsible for the choice, selection and use of the ST products and services described herein, and ST assumes no liability whatsoever relating to the choice, selection or use of the ST products and services described herein.

No license, express or implied, by estoppel or otherwise, to any intellectual property rights is granted under this document. If any part of this document refers to any third party products or services it shall not be deemed a license grant by ST for the use of such third party products or services, or any intellectual property contained therein or considered as a warranty covering the use in any manner whatsoever of such third party products or services or any intellectual property contained therein.

UNLESS OTHERWISE SET FORTH IN ST'S TERMS AND CONDITIONS OF SALE ST DISCLAIMS ANY EXPRESS OR IMPLIED WARRANTY WITH RESPECT TO THE USE AND/OR SALE OF ST PRODUCTS INCLUDING WITHOUT LIMITATION IMPLIED WARRANTIES OF MERCHANTABILITY, FITNESS FOR A PARTICULAR PURPOSE (AND THEIR EQUIVALENTS UNDER THE LAWS OF ANY JURISDICTION), OR INFRINGEMENT OF ANY PATENT, COPYRIGHT OR OTHER INTELLECTUAL PROPERTY RIGHT.

ST PRODUCTS ARE NOT DESIGNED OR AUTHORIZED FOR USE IN: (A) SAFETY CRITICAL APPLICATIONS SUCH AS LIFE SUPPORTING, ACTIVE IMPLANTED DEVICES OR SYSTEMS WITH PRODUCT FUNCTIONAL SAFETY REQUIREMENTS; (B) AERONAUTIC APPLICATIONS; (C) AUTOMOTIVE APPLICATIONS OR ENVIRONMENTS, AND/OR (D) AEROSPACE APPLICATIONS OR ENVIRONMENTS. WHERE ST PRODUCTS ARE NOT DESIGNED FOR SUCH USE, THE PURCHASER SHALL USE PRODUCTS AT PURCHASER'S SOLE RISK, EVEN IF ST HAS BEEN INFORMED IN WRITING OF SUCH USAGE, UNLESS A PRODUCT IS EXPRESSLY DESIGNATED BY ST AS BEING INTENDED FOR "AUTOMOTIVE, AUTOMOTIVE SAFETY OR MEDICAL" INDUSTRY DOMAINS ACCORDING TO ST PRODUCT DESIGN SPECIFICATIONS. PRODUCTS FORMALLY ESCC, QML OR JAN QUALIFIED ARE DEEMED SUITABLE FOR USE IN AEROSPACE BY THE CORRESPONDING GOVERNMENTAL AGENCY.

Resale of ST products with provisions different from the statements and/or technical features set forth in this document shall immediately void any warranty granted by ST for the ST product or service described herein and shall not create or extend in any manner whatsoever, any liability of ST.

ST and the ST logo are trademarks or registered trademarks of ST in various countries.

Information in this document supersedes and replaces all information previously supplied.

The ST logo is a registered trademark of STMicroelectronics. All other names are the property of their respective owners.

© 2014 STMicroelectronics - All rights reserved

STMicroelectronics group of companies

Australia - Belgium - Brazil - Canada - China - Czech Republic - Finland - France - Germany - Hong Kong - India - Israel - Italy - Japan - Malaysia - Malta - Morocco - Philippines - Singapore - Spain - Sweden - Switzerland - United Kingdom - United States of America

www.st.com

