

## Dual D-type flip-flop

Datasheet - production data

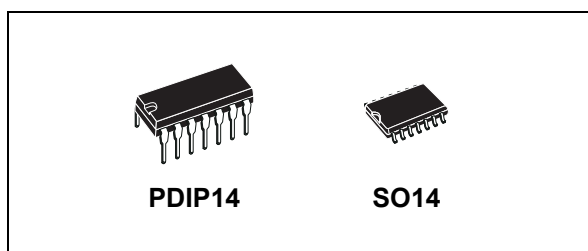

### Features

- Set-reset capability
- Static flip-flop operation - retains state indefinitely with clock level either “high” or “low”
- Medium speed operation 16 MHz (typ.), clock toggle rate at 10 V
- Standardized symmetrical output characteristics
- Quiescent current specified up to 20 V
- 5 V, 10 V, and 15 V parametric ratings
- Input leakage current  $I_l = 100$  nA (max.) at  $V_{DD} = 18$  V,  $T_A = 25$  °C
- 100 % tested for quiescent current
- ESD performance
  - HBM: 2 kV
  - MM: 200 V
  - CDM: 1 kV

### Applications

- Automotive
- Industrial
- Computer
- Consumer

### Description

The HCF4013 is a monolithic integrated circuit fabricated in metal oxide semiconductor technology available in PDIP14 and SO14 packages.

The HCF4013 consists of two identical, independent data type flip-flops. Each flip-flop has independent data, set, reset, and clock inputs, and Q and  $\bar{Q}$  outputs. This device can be used for shift register applications. It can also be used for counter and toggle applications by connecting  $\bar{Q}$  output to the data input.

The logic level present at the D input is transferred to the  $\bar{Q}$  output during the positive-going transition of the clock pulse. Setting or resetting is independent of the clock and is accomplished by a high level on the set or reset line, respectively.

**Table 1. Device summary table**

Order code	Temperature range	Package	Packing	Marking
HCF4013M013TR	-55 °C to +125 °C	SO14	Tape and reel	HCF4013
HCF4013YM013TR (1)	-40 °C to +125 °C	SO14 (automotive grade) <sup>(1)</sup>		HCF4013Y
HCF4013BEY	-55 °C to +125 °C	PDIP14	Tube	HCF4013BE

1. Qualification and characterization according to AEC Q100 and Q003 or equivalent, advanced screening according to AEC Q001 and Q002 or equivalent.

# Contents

<b>1</b>	<b>Pin information</b> .....	<b>3</b>
<b>2</b>	<b>Functional description</b> .....	<b>4</b>
<b>3</b>	<b>Electrical characteristics</b> .....	<b>5</b>
<b>4</b>	<b>Package information</b> .....	<b>10</b>
	4.1 PDIP14 package information .....	10
	4.2 SO14 package information .....	11
<b>5</b>	<b>Ordering information</b> .....	<b>12</b>
<b>6</b>	<b>Revision history</b> .....	<b>12</b>

# 1 Pin information

**Figure 1. Pin connections (top view)**

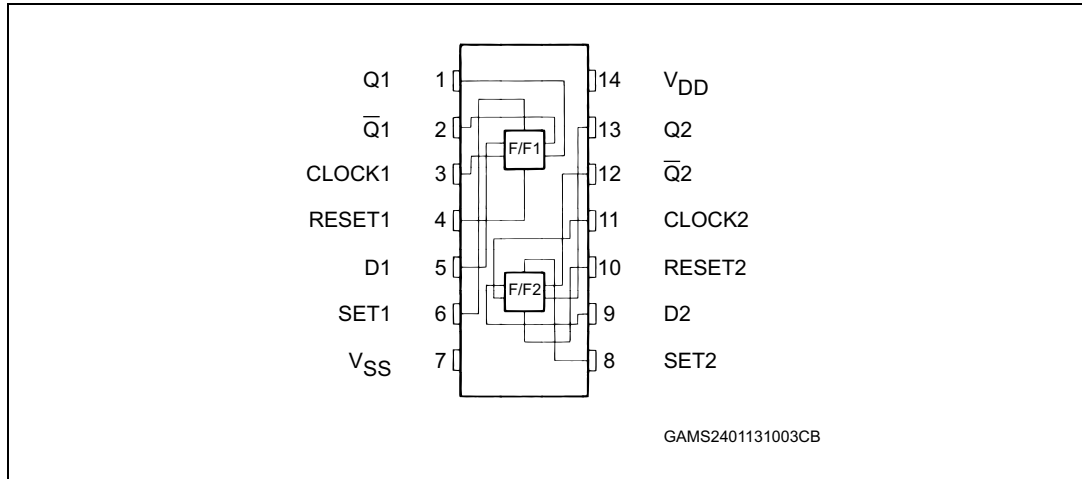
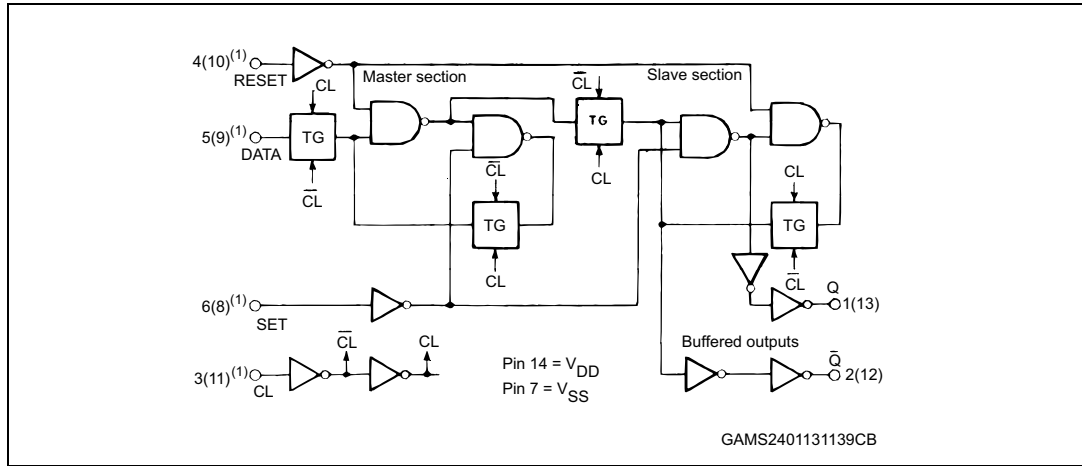

**Table 2. Pin description**

Pin no	Symbol	Name and function
3, 11	CLOCK1 CLOCK2	Clock inputs
4, 10	RESET1 RESET2	Reset inputs
6, 8	SET1, SET2	Set inputs
5, 9	D1, D2	Data inputs
1, 13	Q1, Q2	Data outputs
2, 12	Q $\bar{1}$ , Q $\bar{2}$	Data outputs
7	V $_{SS}$	Negative supply voltage
14	V $_{DD}$	Positive supply voltage

## 2 Functional description

Figure 2. Logic diagram



1. All inputs are protected by a COS/MOS protection network.

Table 3. Truth table

CLOCK <sup>(1)</sup>	D	RESET	SET	Q	$\bar{Q}$
$\text{L}$	L	L	L	L	H
$\text{L}$	H	L	L	H	L
$\text{H}$	X <sup>(2)</sup>	L	L	Q	$\bar{Q}$
X <sup>(2)</sup>	X <sup>(2)</sup>	H	L	L	H
X <sup>(2)</sup>	X <sup>(2)</sup>	L	H	H	L
X <sup>(2)</sup>	X <sup>(2)</sup>	H	H	H	H

1. Low level
2. Don't care

Figure 3. Input equivalent circuit

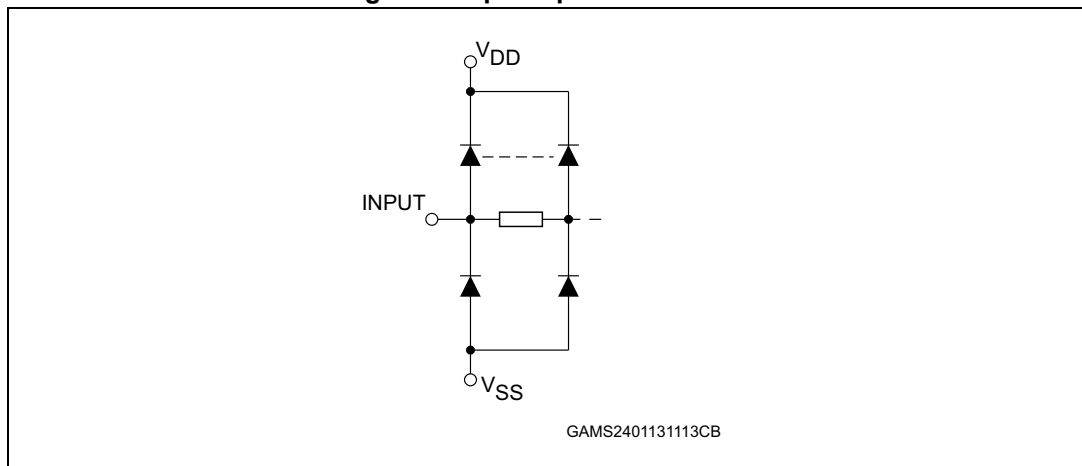

### 3 Electrical characteristics

Absolute maximum ratings are those values beyond which damage to the device may occur. Functional operation under these conditions is not implied. All voltage values are referred to  $V_{SS}$  pin voltage.

**Table 4. Absolute maximum ratings (AMR)**

Symbol	Parameter	Value	Unit
$V_{DD}$	Supply voltage	-0.5 to +22	V
$V_I$	DC input voltage	-0.5 to $V_{DD} + 0.5$	
$I_I$	DC input current	$\pm 10$	mA
$P_D$	Power dissipation per package	200	mW
	Power dissipation per output transistor	100	
$T_{op}$	Operating temperature	-55 to +125	°C
$T_{stg}$	Storage temperature	-65 to +150	

**Table 5. Recommended operating conditions**

Symbol	Parameter	Value	Unit
$V_{DD}$	Supply voltage	3 to 20	V
$V_I$	Input voltage	0 to $V_{DD}$	
$T_{op}$	Operating temperature	-55 to 125	°C

Table 6. DC specifications<sup>(1)</sup>

Sym.	Parameter	Test condition				Value						Unit	
		V <sub>I</sub> (V)	V <sub>O</sub> (V)	I <sub>O</sub>   (μA)	V <sub>DD</sub> (V)	T <sub>A</sub> = 25 °C			-40 to 85 °C		-55 to 125°C		
						Min.	Typ.	Max.	Min.	Max.	Min.		Max.
I <sub>L</sub>	Quiescent current	0/5			5		0.02	1		30		30	μA
		0/10			10		0.02	2		60		60	
		0/15			15		0.02	4		120		120	
		0/20			20		0.04	20		600		600	
V <sub>OH</sub>	High level output voltage	0/5		<1	5	4.95			4.95		4.95		V
		0/10		<1	10	9.95			9.95		9.95		
		0/15		<1	15	14.95			14.95		14.95		
V <sub>OL</sub>	Low level output voltage	5/0		<1	5		0.05			0.05		0.05	V
		10/0		<1	10		0.05			0.05		0.05	
		15/0		<1	15		0.05			0.05		0.05	
V <sub>IH</sub>	High level input voltage		0.5/4.5	<1	5	3.5			3.5		3.5		V
			1/9	<1	10	7			7		7		
			1.5/13.5	<1	15	11			11		11		
V <sub>IL</sub>	Low level input voltage		4.5/0.5	<1	5			1.5		1.5		1.5	V
			9/1	<1	10			3		3		3	
			13.5/1.5	<1	15			4		4		4	
I <sub>OH</sub>	Output drive current	0/5	2.5	<1	5	-1.36	-3.2		-1.15		-1.1		mA
		0/5	4.6	<1	5	-0.44	-1		-0.36		-0.36		
		0/10	9.5	<1	10	-1.1	-2.6		-0.9		-0.9		
		0/15	13.5	<1	15	-3.0	-6.8		-2.4		-2.4		
I <sub>OL</sub>	Output sink current	0/5	0.4	<1	5	0.44	1		0.36		0.36		mA
		0/10	0.5	<1	10	1.1	2.6		0.9		0.9		
		0/15	1.5	<1	15	3.0	6.8		2.4		2.4		
I <sub>I</sub>	Input leakage current	0/18	Any input		18		±10 <sup>-5</sup>	±0.1		±1		±1	μA
C <sub>I</sub>	Input capacitance		Any input				5	7.5					pF

1. The noise margin for both level "1" and "0" is: 1 V min. with V<sub>DD</sub> = 5 V, 2 V min. with V<sub>DD</sub> = 10 V, and 2.5 V min. with V<sub>DD</sub> = 15 V.



**Table 7. Dynamic electrical characteristics**  
 ( $T_{amb} = 25\text{ }^{\circ}\text{C}$ ,  $C_L = 50\text{ pF}$ ,  $R_L = 200\text{ k}\Omega$ ,  $t_r = t_f = 20\text{ ns}$ )

Symbol	Parameter	Test condition	Value <sup>(1)</sup>			Unit
		$V_{DD}$ (V)	Min.	Typ.	Max.	
$t_{TLH}, t_{THL}$	Propagation delay time (CLOCK to Q or Q outputs)	5		150	300	ns
		10		65	130	
		15		45	90	
$t_{PLH}$	Propagation delay time (SET to Q or RESET to Q)	5		150	300	
		10		65	130	
		15		45	90	
$t_{PHL}$	Propagation delay time (SET to Q or RESET to Q)	5		200	400	
		10		85	170	
		15		60	120	
$t_{THL}, t_{TLH}$	Transition time	5		100	200	
		10		50	100	
		15		40	80	
$f_{CL}^{(2)}$	Maximum clock input frequency	5	3.5	7		MHz
		10	8	16		
		15	12	24		
$t_W$	Clock pulse width	5	140	70		ns
		10	60	30		
		15	40	20		
	Set or reset pulse width	5	180	90		
		10	80	40		
		15	50	25		
$t_r, t_f^{(3)}$	Clock input rise or fall time	5			15	$\mu\text{s}$
		10			4	
		15			1	
$t_s$	Data setup time	5	40	20		ns
		10	20	10		
		15	15	7		

1. The typical temperature coefficient for all  $V_{DD}$  values is 0.3 %/°C.

2. Input tr, tf = 5 ns

3. If more than one unit is cascaded in a parallel clocked application, tr should be made less than or equal to the sum of the fixed propagation delay time at 15 pF and the transition time of the carry output driving stage for the estimated capacitive load.

Figure 4. Test circuit

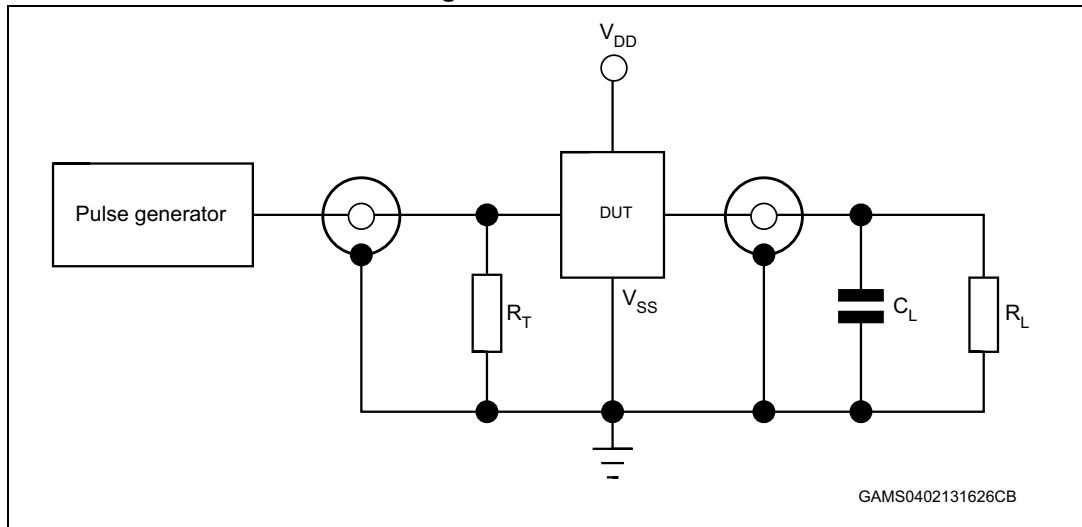

- Legend:  $C_L = 50 \text{ pF}$  or equivalent (includes jig and probe capacitance),  $R_L = 200 \text{ K}\Omega$ ,  $R_T = Z_{OUT}$  of pulse generator (typically  $50 \Omega$ )

Figure 5. Dn to Qn timings (50 % clock duty cycle)

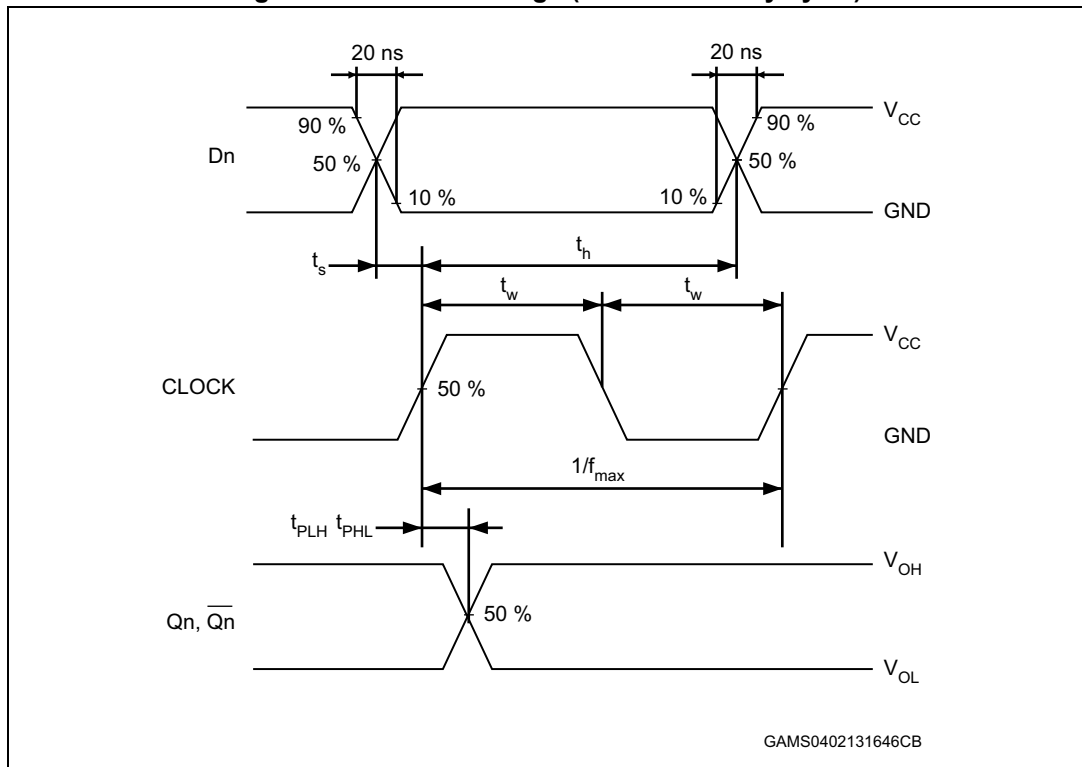
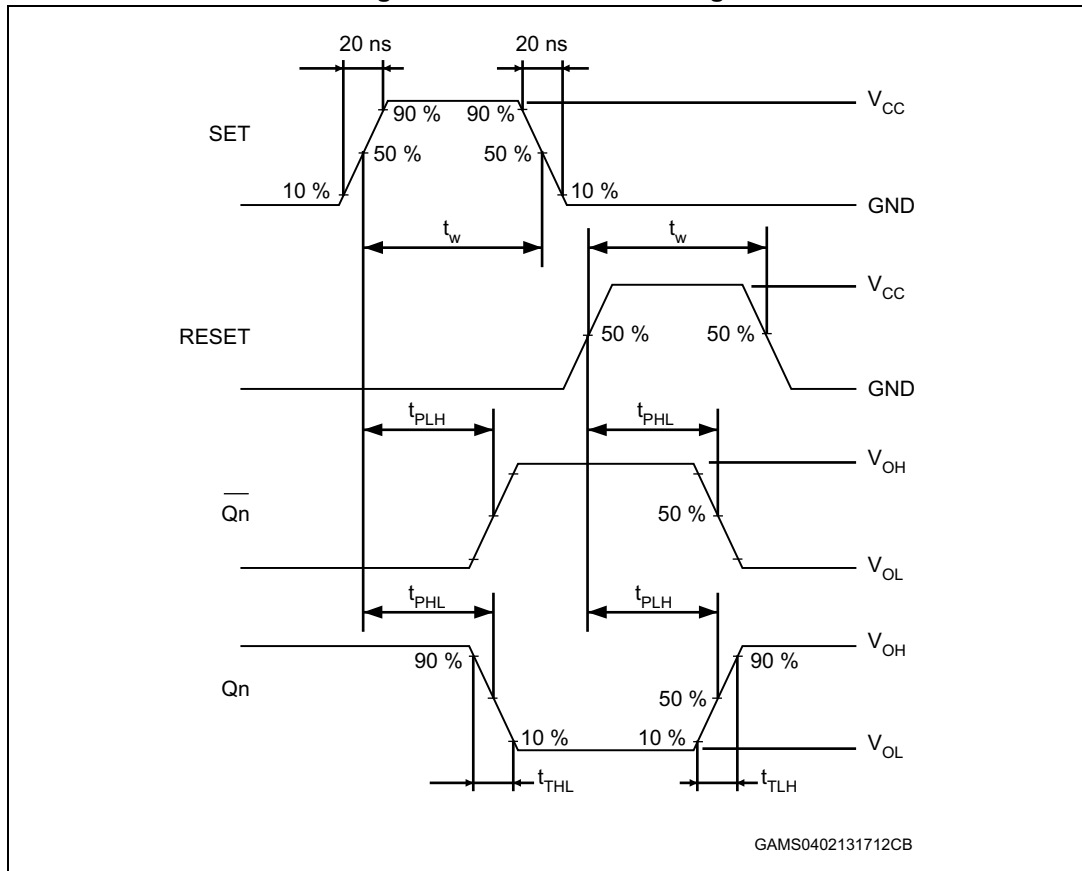

Figure 6. Set and reset timings



## 4 Package information

In order to meet environmental requirements, ST offers these devices in different grades of ECOPACK<sup>®</sup> packages, depending on their level of environmental compliance. ECOPACK<sup>®</sup> specifications, grade definitions and product status are available at: [www.st.com](http://www.st.com). ECOPACK<sup>®</sup> is an ST trademark.

### 4.1 PDIP14 package information

Figure 7. PDIP14 package mechanical drawing

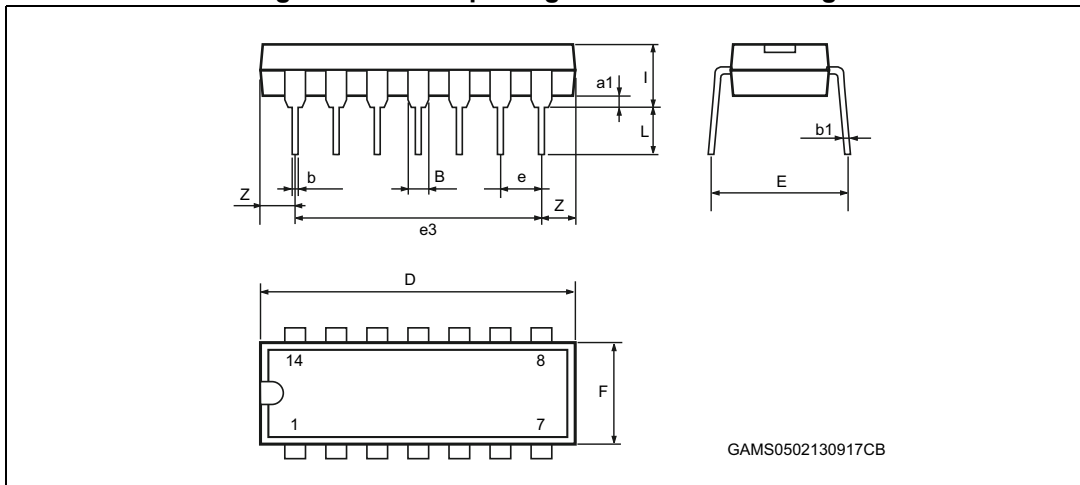

Table 8. PDIP14 package mechanical data

Ref	Dimensions					
	Millimeters			Inches		
	Min.	Typ.	Max.	Min.	Typ.	Max.
a1	0.51			0.020		
B	1.39		1.65	0.055		0.065
b		0.5			0.020	
b1		0.25			0.010	
D			20			0.787
E		8.5			0.335	
e		2.54			0.100	
e3		15.24			0.600	
F			7.1			0.280
l			5.1			0.201
L		3.3			0.130	
Z	1.27		2.54	0.050		0.100

## 4.2 SO14 package information

Figure 8. SO14 package mechanical drawing

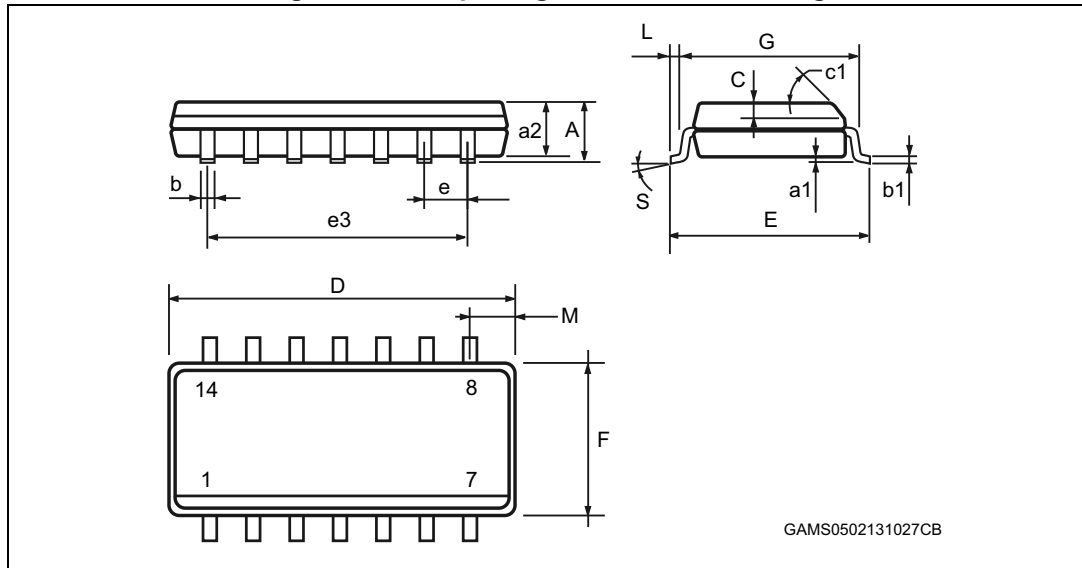

Table 9. SO14 package mechanical data

Ref	Dimensions					
	Millimeters			Inches		
	Min.	Typ.	Max.	Min.	Typ.	Max.
A			1.75			0.068
a1	0.1		0.2	0.003		0.007
a2			1.65			0.064
b	0.35		0.46	0.013		0.018
b1	0.19		0.25	0.007		0.010
C		0.5			0.019	
c1		45 °			45 °	
D	8.55		8.75	0.336		0.344
E	5.8		6.2	0.228		0.244
e		1.27			0.050	
e3		7.62			0.300	
F	3.8		4.0	0.149		0.157
G	4.6		5.3	0.181		0.208
L	0.5		1.27	0.019		0.050
M			0.68			0.026
S			8 °			8 °

## 5 Ordering information

**Table 10. Order codes**

Order code	Temperature range	Package	Packing	Marking
HCF4013M013TR	-55 ° C to +125 ° C	SO14	Tape and reel	HCF4013
HCF4013YM013TR(1)	-40 ° C to +125 ° C	SO14 (automotive grade) <sup>(1)</sup>		HCF4013Y
HCF4013BEY	-55 ° C to +125 ° C	PDIP14	Tube	HCF4013BE

1. Qualification and characterization according to AEC Q100 and Q003 or equivalent, advanced screening according to AEC Q001 and Q002 or equivalent.

## 6 Revision history

**Table 11. Document revision history**

Date	Revision	Changes
Sep-2001	1	Initial release.
18-Feb-2013	2	Document template and layout updated Removed "B" from part number Added ESD information to <a href="#">Features</a> Updated package names (PDIP-14 and SO-14 instead of DIP-14 and SOP-14). Added <a href="#">Applications</a> Added <a href="#">Device summary table</a> Updated symbol names in <a href="#">Table 7</a> Added <a href="#">Section 5: Ordering information</a>
30-Apr-2013	3	<a href="#">Features</a> : updated ESD information
30-May-2013	4	<a href="#">Features</a> : updated ESD information Updated footnote in <a href="#">Table 1</a> and <a href="#">Table 10</a>

**Please Read Carefully:**

Information in this document is provided solely in connection with ST products. STMicroelectronics NV and its subsidiaries ("ST") reserve the right to make changes, corrections, modifications or improvements, to this document, and the products and services described herein at any time, without notice.

All ST products are sold pursuant to ST's terms and conditions of sale.

Purchasers are solely responsible for the choice, selection and use of the ST products and services described herein, and ST assumes no liability whatsoever relating to the choice, selection or use of the ST products and services described herein.

No license, express or implied, by estoppel or otherwise, to any intellectual property rights is granted under this document. If any part of this document refers to any third party products or services it shall not be deemed a license grant by ST for the use of such third party products or services, or any intellectual property contained therein or considered as a warranty covering the use in any manner whatsoever of such third party products or services or any intellectual property contained therein.

**UNLESS OTHERWISE SET FORTH IN ST'S TERMS AND CONDITIONS OF SALE ST DISCLAIMS ANY EXPRESS OR IMPLIED WARRANTY WITH RESPECT TO THE USE AND/OR SALE OF ST PRODUCTS INCLUDING WITHOUT LIMITATION IMPLIED WARRANTIES OF MERCHANTABILITY, FITNESS FOR A PARTICULAR PURPOSE (AND THEIR EQUIVALENTS UNDER THE LAWS OF ANY JURISDICTION), OR INFRINGEMENT OF ANY PATENT, COPYRIGHT OR OTHER INTELLECTUAL PROPERTY RIGHT.**

**ST PRODUCTS ARE NOT AUTHORIZED FOR USE IN WEAPONS. NOR ARE ST PRODUCTS DESIGNED OR AUTHORIZED FOR USE IN: (A) SAFETY CRITICAL APPLICATIONS SUCH AS LIFE SUPPORTING, ACTIVE IMPLANTED DEVICES OR SYSTEMS WITH PRODUCT FUNCTIONAL SAFETY REQUIREMENTS; (B) AERONAUTIC APPLICATIONS; (C) AUTOMOTIVE APPLICATIONS OR ENVIRONMENTS, AND/OR (D) AEROSPACE APPLICATIONS OR ENVIRONMENTS. WHERE ST PRODUCTS ARE NOT DESIGNED FOR SUCH USE, THE PURCHASER SHALL USE PRODUCTS AT PURCHASER'S SOLE RISK, EVEN IF ST HAS BEEN INFORMED IN WRITING OF SUCH USAGE, UNLESS A PRODUCT IS EXPRESSLY DESIGNATED BY ST AS BEING INTENDED FOR "AUTOMOTIVE, AUTOMOTIVE SAFETY OR MEDICAL" INDUSTRY DOMAINS ACCORDING TO ST PRODUCT DESIGN SPECIFICATIONS. PRODUCTS FORMALLY ESCC, QML OR JAN QUALIFIED ARE DEEMED SUITABLE FOR USE IN AEROSPACE BY THE CORRESPONDING GOVERNMENTAL AGENCY.**

Resale of ST products with provisions different from the statements and/or technical features set forth in this document shall immediately void any warranty granted by ST for the ST product or service described herein and shall not create or extend in any manner whatsoever, any liability of ST.

ST and the ST logo are trademarks or registered trademarks of ST in various countries.

Information in this document supersedes and replaces all information previously supplied.

The ST logo is a registered trademark of STMicroelectronics. All other names are the property of their respective owners.

© 2013 STMicroelectronics - All rights reserved

STMicroelectronics group of companies

Australia - Belgium - Brazil - Canada - China - Czech Republic - Finland - France - Germany - Hong Kong - India - Israel - Italy - Japan - Malaysia - Malta - Morocco - Philippines - Singapore - Spain - Sweden - Switzerland - United Kingdom - United States of America

[www.st.com](http://www.st.com)

