



# Application Note: AN\_SY8003/SY8003A

## High Efficiency 5.5V, 3A continuous, 1MHz Synchronous Step Down Regulator

### General Description

The SY8003 and SY8003A are high-efficiency, high frequency synchronous step-down DC-DC regulator IC capable of delivering up to 3A output current. The SY8003 and SY8003A operate over a wide input voltage range from 2.7V to 5.5V and integrate main switch and synchronous switch with very low  $R_{DS(ON)}$  to minimize the conduction loss.

Low output voltage ripple and small external inductor and capacitor sizes are achieved with 1MHz switching frequency.

SY8003 and SY8003A integrate reliable short circuit and over-voltage protection.

### Features

- Low  $R_{DS(ON)}$  for internal switches (top/bottom): 110mΩ/80mΩ
- 3A continuous load current capability
- 2.7-5.5V input voltage range
- High switching frequency minimizes the external components: 1MHz
- Internal softstart limits the inrush current
- Reliable short circuit protection:  
SY8003: Latch off protection  
SY8003A: Hic-cup mode protection
- Reliable over-voltage protection:  
SY8003: Latch off protection  
SY8003A: No latch off protection
- 100% dropout operation
- RoHS Compliant and Halogen Free
- Compact package: DFN2X2-8.

### Ordering Information

SY8003 ( )  
 --- Temperature Code  
 --- Package Code  
 --- Optional Spec Code

Ordering Number	Package type	Note①
SY8003DFC	DFN2x2-8	
SY8003ADFC	DFN2x2-8	

### Applications

- LCD TV
- Set Top Box
- Net PC
- Mini-Notebook PC
- Access Point Router

### Typical Applications

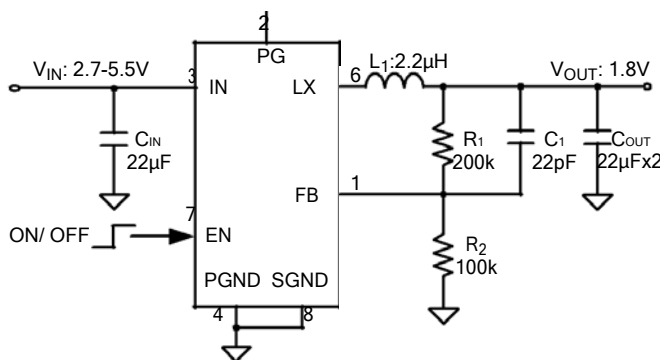

Figure 1. Schematic diagram

### Efficiency vs. Load Current

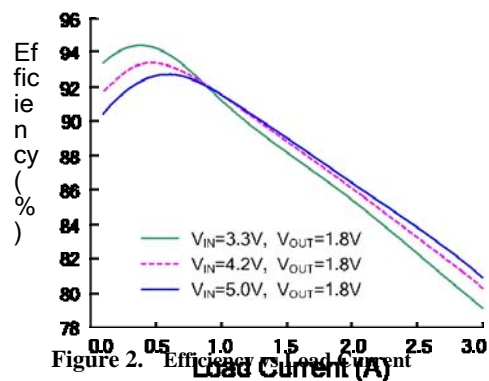

Figure 2. Efficiency vs. Load Current



SILERGY

# SY8003/SY8003A

## Pinout (top view)

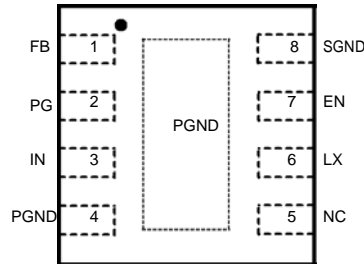

Part Number	Package type	Top Mark
SY8003DFC	DFN2x2-8	<b>JDxyz</b>
SY8003ADFC	DFN2x2-8	<b>KWxyz</b>

Note ① : x=year code, y=week code, z= lot number code.

Pin Name	Pin Number	Pin Description
EN	7	Enable control. Pull high to turn on. Do not float.
PGND	4/Exposed Paddle	Power ground pin.
SGND	8	Signal ground pin.
LX	6	Inductor pin. Connect this pin to the switching node of inductor.
IN	3	Power input pin. Decouple this pin to GND pin with at least 10μF ceramic cap.
PG	2	Power good indicator(Open drain output). Low if the output < 90% of regulation voltage or >120% regulation voltage; High otherwise. Connect a pull-up resistor to the input.
FB	1	Output Feedback Pin. Connect this pin to the center point of the output resistor divider (as shown in Figure 1) to program the output voltage: $V_{out}=0.6*(1+R_1/R_2)$ .
NC	5	No connection.

## Absolute Maximum Ratings (Note 1)

Supply Input Voltage	-0.3V to 6.0V
Enable, FB Voltage	- 0.3V to $V_{IN} + 0.6V$
LX Voltage	0.3V <sup>(*)</sup> to 6V <sup>(**)</sup>
Power Dissipation, PD @ TA = 25°C DFN2x2-8 ,	1W
Package Thermal Resistance (Note 2)	
$\theta_{JA}$	120°C/W
$\theta_{JC}$	8.2°C/W
Junction Temperature Range	150°C
Lead Temperature (Soldering, 10 sec.)	260°C
Storage Temperature Range	65°C to 150°C
<sup>(*)</sup> LX Voltage tested down to -5V<10ns	
<sup>(**)</sup> LX Voltage tested up to +7V<50ns	

## Recommended Operating Conditions (Note 3)

Supply Input Voltage	2.7V to 5.5V
Junction Temperature Range	40°C to 125°C
Ambient Temperature Range	-40°C to 85°C

Block Diagram

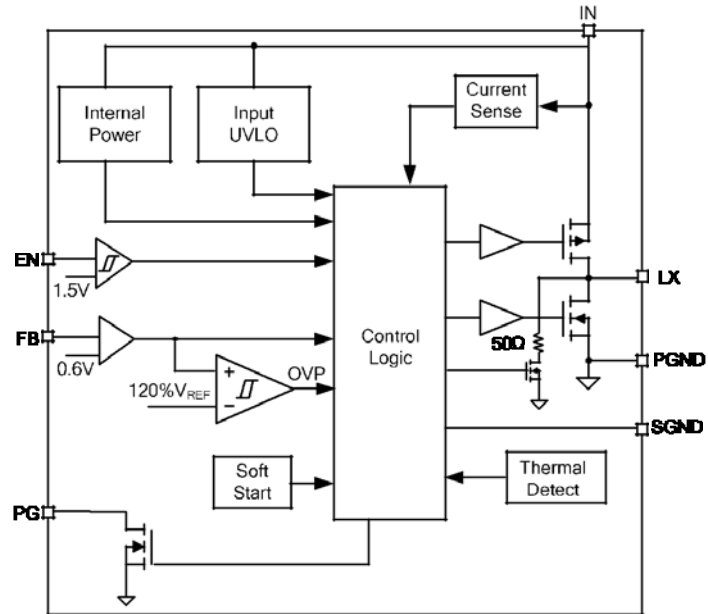

(SY8003)

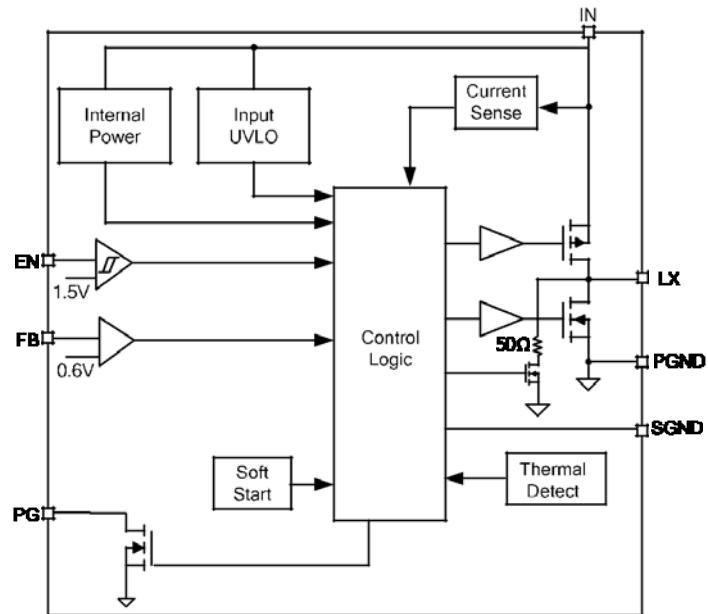

(SY8003A)



**Electrical Characteristics**

( $V_{IN} = 5V$ ,  $V_{OUT} = 2.5V$ ,  $L = 2.2\mu H$ ,  $C_{OUT} = 22\mu F$ ,  $T_A = 25^\circ C$ , unless otherwise specified)

Parameter	Symbol	Test Conditions	Min	Typ	Max	Unit
Input Voltage Range	$V_{IN}$		2.7		5.5	V
Quiescent Current	$I_Q$	$I_{OUT}=0$ , $V_{FB}=V_{REF} \cdot 105\%$		55		$\mu A$
Shutdown Current	$I_{SHDN}$	EN=0		0.1	1	$\mu A$
Feedback Reference Voltage	$V_{REF}$		0.588	0.6	0.612	V
FB Input Current	$I_{FB}$	$V_{FB} = V_{IN}$	-50		50	nA
PFET RON	$R_{DS(ON)P}$			110		m $\Omega$
NFET RON	$R_{DS(ON)N}$			80		m $\Omega$
PFET Current Limit	$I_{LIM}$		3.5			A
EN rising threshold	$V_{ENH}$		1.5			V
EN falling threshold	$V_{ENL}$				0.4	V
EN Leakage current	$I_{EN}$		-1		1	$\mu A$
Input UVLO threshold	$V_{UVLO}$				2.5	V
UVLO hysteresis	$V_{HYS}$			0.2		V
Oscillator Frequency	$f_{OSC}$	$I_{OUT}=500mA$	0.8	1	1.2	MHz
PG High Delay Time				0.1	1	$\mu s$
PG Rising Threshold	$V_{FB,HV}$			0.54		V
PG Under-voltage Threshold	$V_{FB,LV}$			0.54		V
PG Under-voltage Delay Time				20		$\mu s$
PG Over-voltage Threshold	$V_{FB,OV}$		0.69	0.72	0.75	V
Over-voltage Protection Threshold	$V_{OVP}$		0.69	0.72	0.75	V
Over-voltage Deglitch Timeout	$t_{OV}$		10	20	30	$\mu s$
Short Circuit Protection Latch Off Threshold	$V_{SCP}$	SY8003DFC		0.24		V
Short Circuit Protection Delay Time	$t_{DELAY-SC}$			20		$\mu s$
Min ON Time				75		ns
Max Duty Cycle			100			%
Soft Start Time	$t_{SS}$		0.84	1.2	1.56	ms
Output Discharge Switch On Resistance	$R_{DISCH}$			50		$\Omega$
Thermal Shutdown Temperature	$T_{SD}$			160		$^\circ C$

**Note 1:** Stresses beyond the “Absolute Maximum Ratings” may cause permanent damage to the device. These are stress ratings only. Functional operation of the device at these or any other conditions beyond those indicated in the operational sections of the specification is not implied. Exposure to absolute maximum rating conditions for extended periods may affect device reliability.

**Note 2:** Test condition: Device mounted on 2” x 2” FR-4 substrate PCB, 2oz copper, with minimum recommended pad on top layer and thermal vias to bottom layer ground plane.

**Note 3:** The device is not guaranteed to function outside its operating conditions.



SILERGY

# SY8003/SY8003A

## Typical Performance Characteristics

Efficiency vs. Load Current

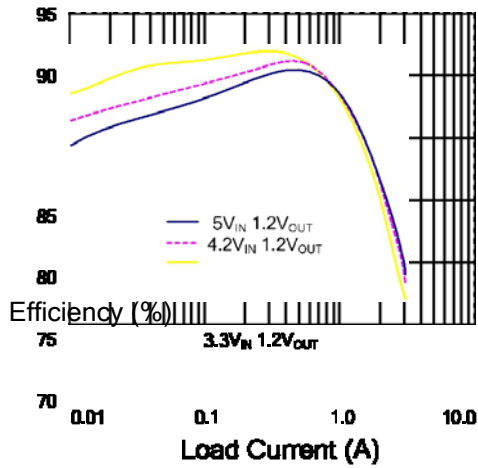

Efficiency vs. Load Current

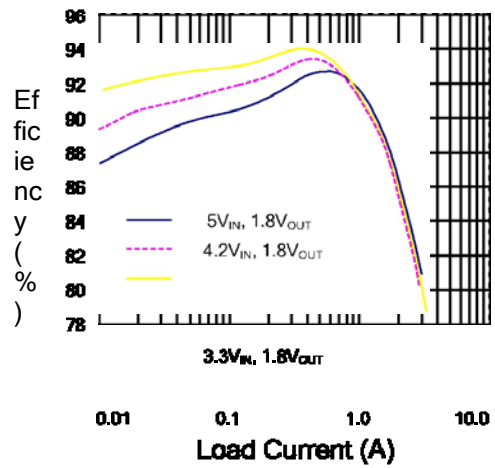

Efficiency vs. Load Current

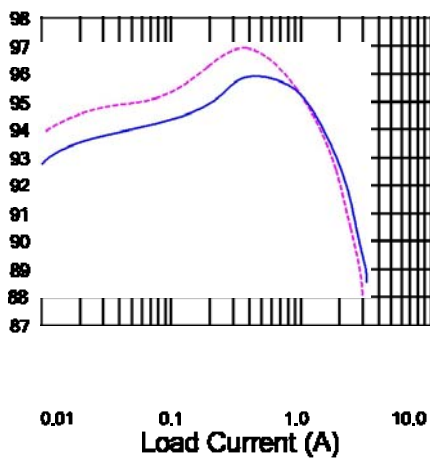

Efficiency (%)

Output Ripple

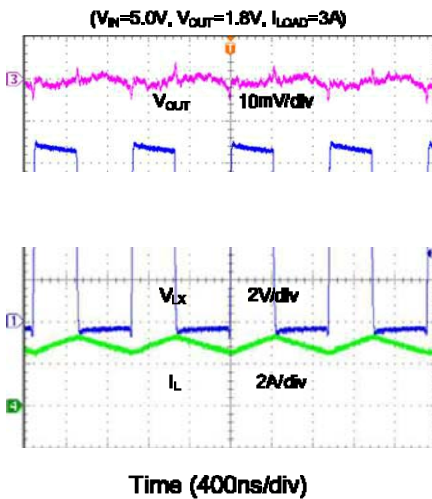

Startup from Enable  
(V<sub>IN</sub>=5.0V, V<sub>OUT</sub>=1.8V, I<sub>LOAD</sub>=3.0A)

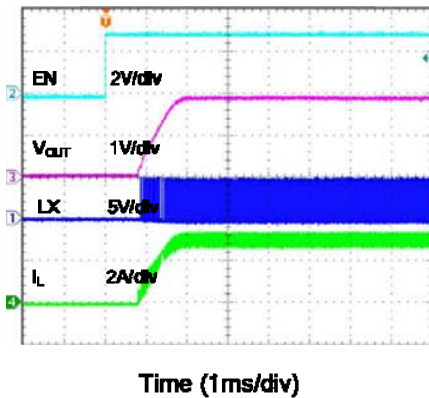

Shutdown from Enable  
(V<sub>IN</sub>=5.0V, V<sub>OUT</sub>=1.8V, I<sub>LOAD</sub>=3.0A)

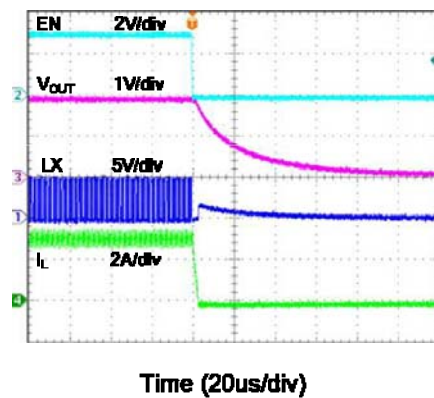



# SY8003/SY8003A

**Load Transient**  
 ( $V_{IN}=5.0V, V_{OUT}=1.8V, I_{LOAD}=0-1.5A$ )

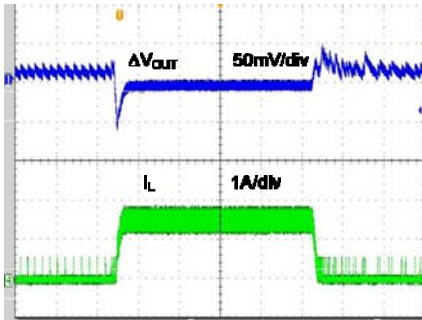

Time (100μs/div)

**Load Transient**  
 ( $V_{IN}=5.0V, V_{OUT}=1.8V, I_{LOAD}=0.3-3.0A$ )

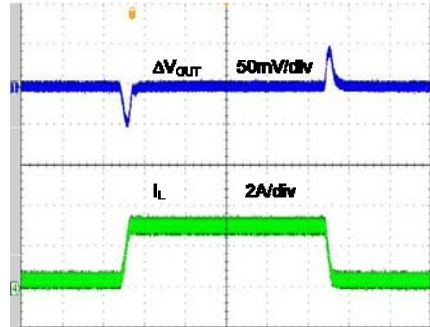

Time (100μs/div)

**Short Circuit Protection**  
 ( $V_{IN}=5.0V, V_{OUT}=1.8V, I_{LOAD}=0A$ -Short SY8003)

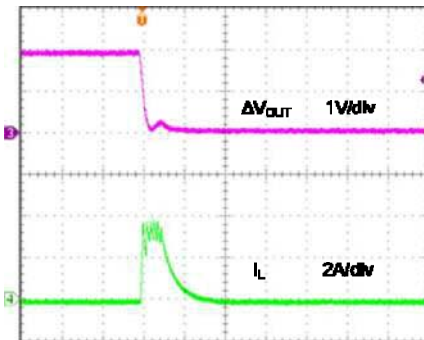

Time (40μs/div)

**Short Circuit Protection**  
 ( $V_{IN}=5.0V, V_{OUT}=1.8V, I_{LOAD}=3.0A$ -Short SY8003)

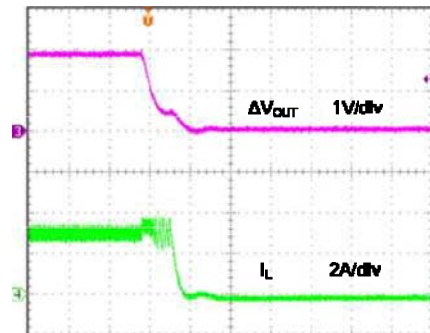

Time (40μs/div)

**Short Circuit Protection**  
 ( $V_{IN}=5.0V, V_{OUT}=1.8V, I_{LOAD}=0A$ -Short SY8003A)

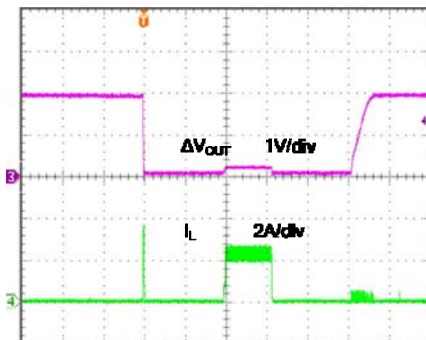

Time (2ms/div)

**Short Circuit Protection**  
 ( $V_{IN}=5.0V, V_{OUT}=1.8V, I_{LOAD}=3.0A$ -Short SY8003A)

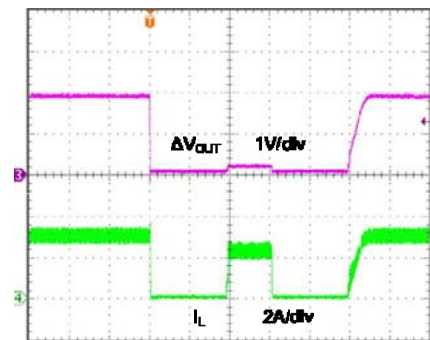

Time (2ms/div)



SILERGY

# SY8003/SY8003A

## Operation Principle

SY8003 is a synchronous buck regulator IC that integrates the PWM control, top and bottom switches on the same die to minimize the switching transition loss and conduction loss. With ultra low R<sub>DS(ON)</sub> power switches and proprietary PWM control, this regulator IC can achieve the highest efficiency and the highest switch frequency simultaneously to minimize the external inductor and capacitor size, and thus achieving the minimum solution footprint.

### Short Circuit Protection

(SY8003) After the soft start is over, if the output voltage falls below 40% of the regulation level, IC will turn off both power switches, entering short circuit protection. It will remain in this state until the IN or EN voltage is recycled.

(SY8003A) The frequency is folded back to about 30% of the nominal frequency and the current limit is folded back to 3.0A to prevent the inductor current from runaway and to reduce the power dissipation of the IC under short circuit conditions.

### Over-voltage Protection(SY8003 Only)

If the output voltage exceeds 120% of the regulation level for more than 20µs, IC will turn off both power switches and turn on the discharge switch, entering over-voltage protection. It will remain in this state until IN or EN voltage is recycled.

### Feedback resistor dividers R1 and R2:

Choose R<sub>1</sub> and R<sub>2</sub> to program the proper output voltage. To minimize the power consumption under light loads, it is desirable to choose large resistance values for both R<sub>1</sub> and R<sub>2</sub>. A value of between 10k and 1M is highly recommended for both resistors. If V<sub>OUT</sub> is 1.8V, R<sub>1</sub>=100k is chosen, then R<sub>2</sub> can be calculated to be 50k.

$$R_2 = \frac{0.6V}{V_{OUT} - 0.6V} \cdot R_1 (\Omega)$$

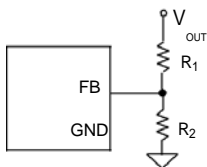

### Input capacitor C<sub>IN</sub>:

This ripple current through input capacitor is calculated as:

$$I_{CIN\_RMS} = I_{OUT} \times \sqrt{D(1-D)}$$

This formula has a maximum at V<sub>IN</sub>=2V<sub>OUT</sub> condition, where I<sub>CIN\_RMS</sub>=I<sub>OUT</sub>/2. This simple worst-case condition is commonly used for DC/DC design.

With the maximum load current at 3.0A. A typical X5R or better grade ceramic capacitor with 6.3V rating and more than 1 pcs 22µ F capacitor can handle this ripple current well. To minimize the potential noise problem, ceramic capacitor should really be placed close to the IN and GND pins. Care should be taken to minimize the loop area formed by CIN, and IN/GND pins

### Output capacitor C<sub>OUT</sub>:

The output capacitor is selected to handle the output ripple noise requirements. Both steady state ripple and transient requirements must be taken into consideration when selecting this capacitor. For the best performance, it is recommended to use X5R or better grade ceramic capacitor with 6.3V rating and greater than 22µF capacitance.

### Output inductor L:

There are several considerations in choosing this inductor.

- 1) Choose the inductance to provide the desired ripple current. It is suggested to choose the ripple current to be about 40% of the maximum output current. The inductance is calculated as:

$$L = \frac{V_{OUT} (1 - \frac{V_{OUT}}{V_{IN,MAX}})}{F_{SW} \times I_{OUT,MAX} \times 40\%}$$

where F<sub>sw</sub> is the switching frequency and I<sub>OUT,MAX</sub> is the maximum load current.

The SY8003 regulator IC is quite tolerant of different ripple current amplitude. Consequently, the final choice of inductance can be slightly off the calculation value without significantly impacting the performance.

- 2) The saturation current rating of the inductor must be selected to be greater than the peak inductor current under full load conditions.

$$I_{SAT,MIN} > I_{OUT,MAX} + \frac{V_{OUT} (1 - V_{OUT}/V_{IN,MAX})}{2 \cdot F_{SW} \cdot L}$$

- 3) The DCR of the inductor and the core loss at the switching frequency must be low enough to achieve the desired efficiency requirement. It is



SILERGY

## SY8003/SY8003A

desirable to choose an inductor with  $DCR < 50m\Omega$  to achieve a good overall efficiency.

### Enable Operation

Pulling the EN pin low ( $< 0.4V$ ) will shut down the device. During shut down mode, the SY8003 shutdown current drops to lower than  $0.1\mu A$ . Driving the EN pin high ( $> 1.5V$ ) will turn on the IC again.

### Load Transient Considerations:

The SY8003 regulator IC integrates the compensation components to achieve good stability and fast transient responses. In some applications, adding a  $22pF$  ceramic cap in parallel with  $R_1$  may further speed up the load transient responses and is thus recommended for applications with large load transient step requirements.

### Layout Design:

The layout design of SY8003 regulator is relatively simple. For the best efficiency and minimum noise problems, we should place the following components close to the IC:  $C_{IN}$ , L,  $R_1$  and  $R_2$ .

- 1) It is desirable to maximize the PCB copper area connecting to GND pin to achieve the best thermal and noise performance. If the board space allowed, a ground plane is highly desirable.
- 2)  $C_{IN}$  must be close to Pins IN and GND. The loop area formed by  $C_{IN}$  and GND must be minimized.

- 3) The PCB copper area associated with LX pin must be minimized to avoid the potential noise problem.
- 4) The components  $R_1$ ,  $R_2$ , and the trace connecting to the FB pin must NOT be adjacent to the LX net on the PCB layout to avoid the noise problem.
- 4) If the system chip interfacing with the EN pin has a high impedance state at shutdown mode and the IN pin is connected directly to a power source such as a LiIon battery, it is desirable to add a pull down  $1M\Omega$  resistor between the EN and GND pins to prevent the noise from falsely turning on the regulator at shutdown mode.

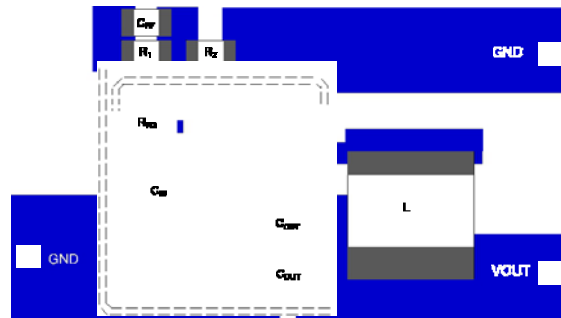

**DFN2x2-8 Package Outline**

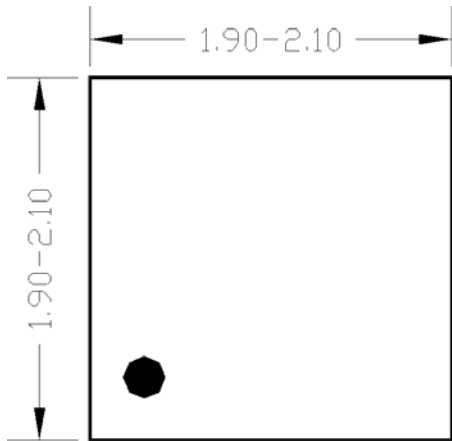

**Top View**

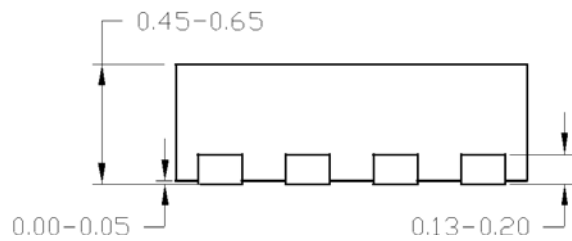

**Side View**

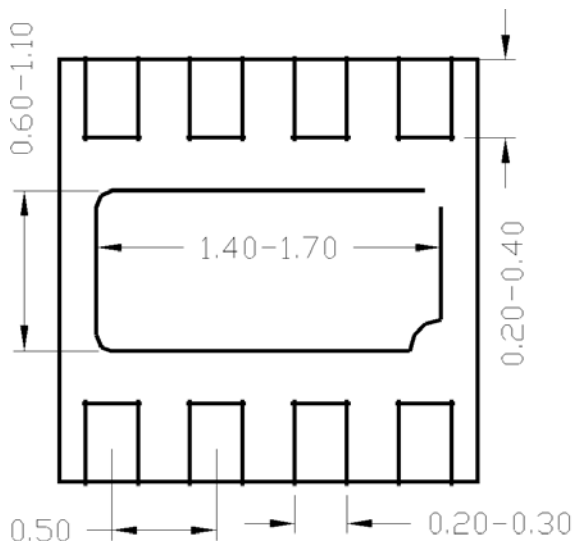

**Bottom View**

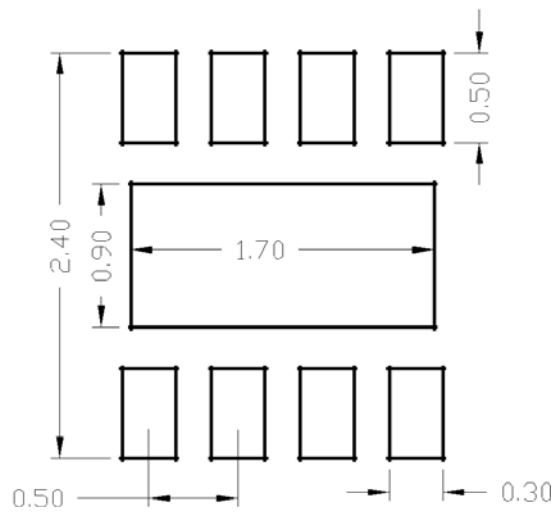

**PCB Layout (Reference Only)**

**Notes:** All dimension in MM  
 All dimension don't not include mold flash & metal burr

**Taping & Reel Specification**

**1. DFN2x2**

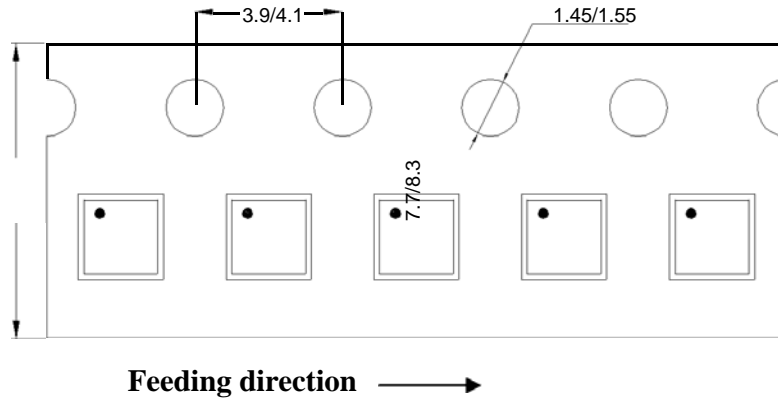

**2. Carrier Tape & Reel specification for packages**

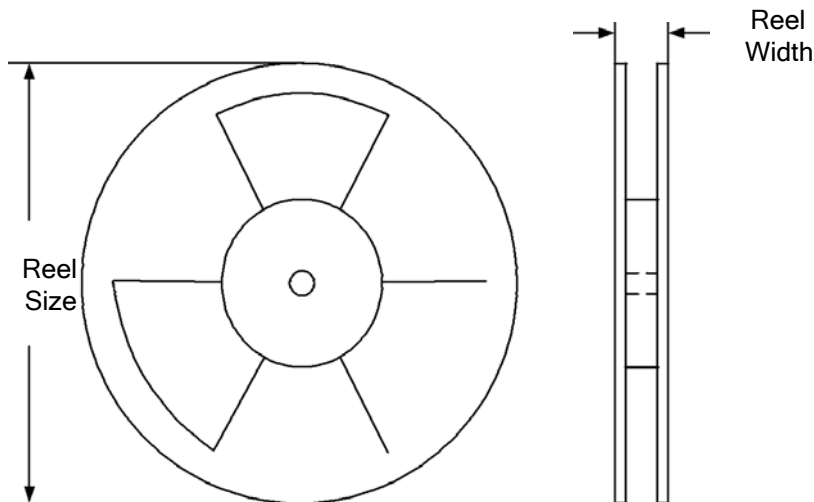

Package types	Tape width (mm)	Pocket pitch(mm)	Reel size (Inch)	Reel width(mm)	Trailer length(mm)	Leader length (mm)	Qty per reel
DFN2x2	8	4	7"	8.4	400	160	3000

**3. Others: NA**