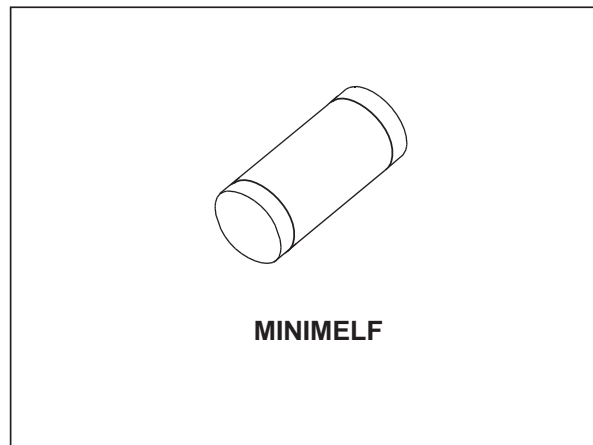

FEATURES

- V_{BO} : 32V
- Breakover voltage range: 28 to 36V

DESCRIPTION

Functioning as a trigger diode with a fixed voltage reference, the TMMDB3 can be used in conjunction with triacs for simplified gate control circuits or as a starting element in fluorescent lamp ballasts.

**ABSOLUTE MAXIMUM RATINGS** (limiting values)

Symbol	Parameter	Value	Unit
I_{TRM}	Repetitive peak on-state current $t_p = 20 \mu s$ $F = 120 \text{ Hz}$	2	A
T_{stg} T_j	Storage temperature range Operating junction temperature range	- 40 to + 125	°C

TMMDB3

ELECTRICAL CHARACTERISTICS (T_j = 25°C unless otherwise specified)

Symbol	Parameter	Test Conditions	Value	Unit	
V _{BO}	Breakover voltage *	C = 22nF **	MIN.	28	V
			TYP.	32	
			MAX.	36	
V _{BO1} - V _{BO2}	Breakover voltage symmetry	C = 22nF **	MAX.	± 3	V
ΔV	Dynamic breakover voltage *	V _{BO} and V _F at 10mA	MIN.	5	V
V _O	Output voltage *	see diagram 2 (R=20Ω)	MIN.	5	V
I _{BO}	Breakover current *	C = 22nF **	MAX.	50	μA
t _r	Rise time *	see diagram 3	MAX.	2	μs
I _R	Leakage current *	V _R = 0.5 V _{BO} max	MAX.	10	μA

* Applicable to both forward and reverse directions.

** Connected in parallel to the device.

ORDERING INFORMATION

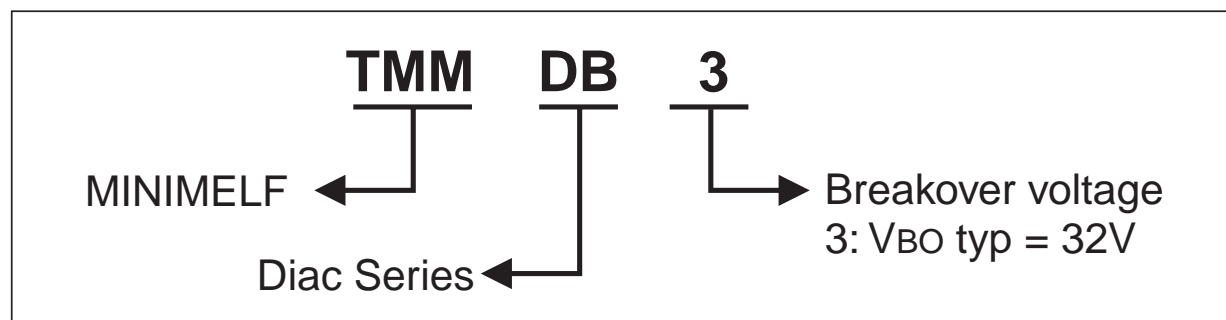

OTHER INFORMATION

Part Number	Marking	Weight	Base Quantity	Packing Mode
TMMDB3	(None)	0.04 g	2500	Tape & Reel

Diagram 1: Voltage - current characteristic curve.

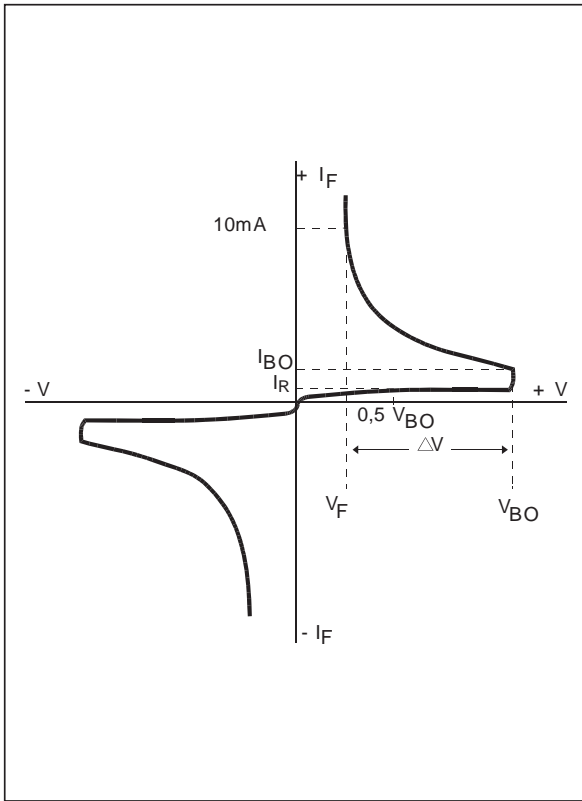

Diagram 2: Test circuit.

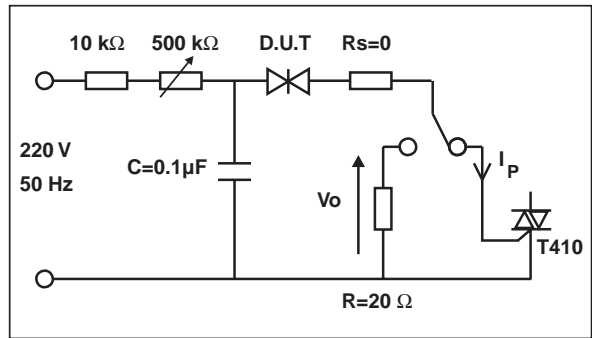

Diagram 3: Rise time measurement.

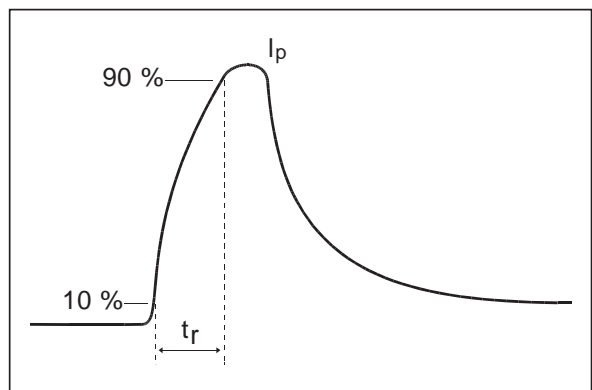

Fig. 1: Relative variation of VBO versus junction temperature (typical values)

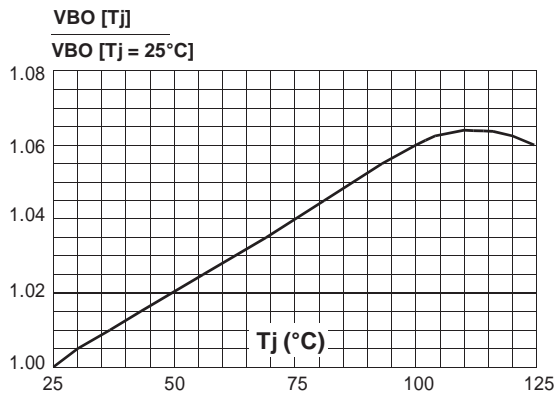

Fig. 2: Repetitive peak pulse current versus pulse duration (maximum values).

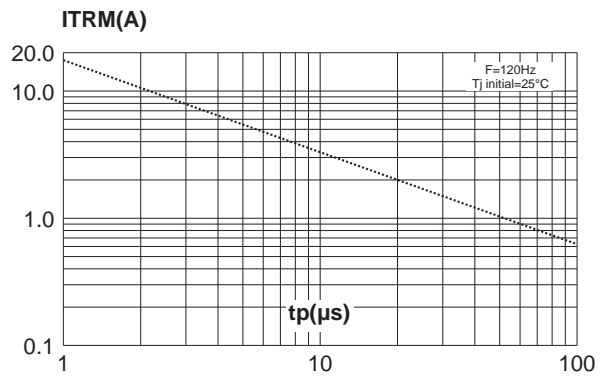
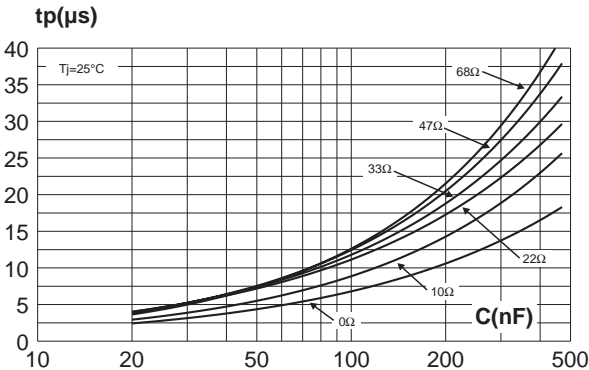

Fig. 3: Time duration while current pulse is higher 50mA versus C and Rs (typical values).



PACKAGE MECHANICAL DATA (in millimeters)
MINIMELF

REF.	DIMENSIONS					
	Millimeters			Inches		
	Min.	Typ.	Max.	Min.	Typ.	Max.
A	3.30	3.40	3.6	0.130	0.134	0.142
B	1.59	1.60	1.62	0.063	0.063	0.064
C	0.40	0.45	0.50	0.016	0.018	0.020
D		1.50			0.059	

FOOTPRINT

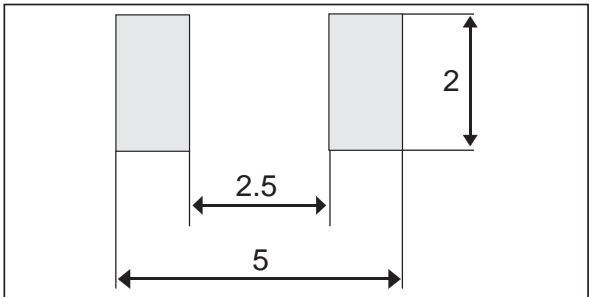

Information furnished is believed to be accurate and reliable. However, STMicroelectronics assumes no responsibility for the consequences of use of such information nor for any infringement of patents or other rights of third parties which may result from its use. No license is granted by implication or otherwise under any patent or patent rights of STMicroelectronics. Specifications mentioned in this publication are subject to change without notice. This publication supersedes and replaces all information previously supplied. STMicroelectronics products are not authorized for use as critical components in life support devices or systems without express written approval of STMicroelectronics.

The ST logo is a registered trademark of STMicroelectronics

© 2001 STMicroelectronics - Printed in Italy - All rights reserved.

STMicroelectronics GROUP OF COMPANIES

Australia - Brazil - China - Finland - France - Germany - Hong Kong - India - Italy - Japan - Malaysia
Malta - Morocco - Singapore - Spain - Sweden - Switzerland - United Kingdom - U.S.A.

<http://www.st.com>

