

4

3

2

1

THIS DRAWING IS UNPUBLISHED. RELEASED FOR PUBLICATION 2-1437565-7, 2-1437565-7
 © COPYRIGHT 2-1437565-7 ALL RIGHTS RESERVED.

LOC	DIST	REVISIONS			
P	LTR	DESCRIPTION	DATE	DWN	APVD
AD	00	V	REVISED PER ECO-15-002755	28FEB2015	NK RH

SPECIFICATIONS:

MATERIALS:

CASE: GLASS FILLED PPS, UL94V-0 BROWN
 COVER: STAINLESS STEEL
 ACTUATOR BUTTON: SEE TABLE - UL94V-0
 MOVING CONTACT: COPPER ALLOY, SILVER CLAD
 MOVING CONTACT: (1571563-1,-2,-7&-8), STAINLESS STEEL,
 AG CLAD OVER NICKEL
 FIXED CONTACT/TERMINAL, COPPER ALLOY-SILVER OVER NICKEL PLATE

ELECTRICAL:

MAX CONTACT RATING: 50MILLIAMPS@24V DC
 MIN CONTACT RATING: 10MICROAMPS@1V DC
 INITIAL CONTACT RESISTANCE: 100 MILLIOHMS MAX.
 INSULATION RESISTANCE: 100 MEGOHMS AT 100 VDC MIN.
 DIELECTRIC STRENGTH: 500 VAC 50/60 Hz FOR 1 MINUTE.
 LIFE EXPECTANCY: (SEE TABLE)

MECHANICAL:

ACTUATION FORCE: (SEE TABLE)
 ACTUATION TRAVEL: 0.25 +0.20/-0.10 [.010 +.008/-.004]

ENVIRONMENTAL:

OPERATING TEMPERATURE: -35°C TO +85°C
 STORAGE TEMPERATURE: -35°C TO +85°C
 SOLDER HEAT RESISTANCE PER 109-201, CONDITION B

SOLDERABILITY:

SPECIFICATION EIA-364-52, CLASS 1, CATEGORY 2

- 1 TAPE AND REEL PACKAGING PER EIA 481.
- 2 ALL MATERIALS AND FINISHES SHALL COMPLY WITH EU DIRECTIVE 2002/95/EC OF 27JAN2003 (ROHS)

6.00 [.236]
 $\phi 3.50$ [.138]

0.80±0.05 [.031±.002] 4X REF
 0.25 [.010]
 0.40 [.016] MAX.
 8.40 [.331] REF
 10.00 [.394]
 4.50±0.10 [.177±.004]
 1 3
 2 4
 0.10±0.05 [.004±.002]
 3.57 [.140]
 DIM."A"
 DIM."B"
 TERMINAL NUMBERS

FSM2JSMA AS SHOWN

2.10 [.083]
 3 1
 11.20 [.441]
 7.00 [.276]
 4 2
 1.40 [.055]
 3.10 [.122]
 5.86 [.231]

0.30±0.10 [.012±.004]
 0.70 [.028] 4X
 3.50 [.138]
 3.30 [.130]
 DIM B (7.01 [.276]) AND LONGER MODELS

()-INDICATES MOMENTARY POSITION		
CIRCUIT CHARACTERISTICS		
CONTACT POSITION	CIRCUIT DIAGRAM	
OFF	(ON)	1 3 2 4
1 - 3 2 - 4	2 4	

THIS DRAWING IS A CONTROLLED DOCUMENT.		DWN D.SARKISIAN 04MAY04	TE Connectivity	
DIMENSIONS: mm [INCHES]		CHK D.SARKISIAN 22APR94	NAME MICRO MINIATURE PUSHBUTTON SWITCH FSM JSM	
TOLERANCES UNLESS OTHERWISE SPECIFIED:		APVD D.SARKISIAN 22APR94	SIZE A2	CAGE CODE 00779
0 PLC ± - 1 PLC ± - 2 PLC ± 0.30 [.012] 3 PLC ± - 4 PLC ± - ANGLES ± 1°		PRODUCT SPEC APPLICATION SPEC	DRAWING NO C=2-1437565-7	RESTRICTED TO -
MATERIAL -	FINISH -	WEIGHT -	SCALE 8:1	SHEET 1 of 2
CUSTOMER DRAWING			REV V	

1471-9 (3/11)

2-1437565-7

A

THIS DRAWING IS UNPUBLISHED. RELEASED FOR PUBLICATION 2-1437565-7, 2-1437565-7
 © COPYRIGHT 2-1437565-7 ALL RIGHTS RESERVED.

LOC	DIST	REVISIONS					
AD	00	P	LTR	DESCRIPTION	DATE	DWN	APVD
		-		SEE SHEET 1		-	-

		100,000	WHITE	NYLON	260G±50G	12MM	24MM	13.00±0.10 [.512±.010]	9.40±0.10 [.370±.004]	FSM14JSMAATR	1571563-6
		100,000	WHITE	NYLON	260G±50G	-	-	13.00±0.10 [.512±.010]	9.40±0.10 [.370±.004]	FSM14JSMAA	1571563-5
OBSOLETE		100,000	BROWN	NYLON	100G±50G	-	-	13.00±0.10 [.512±.010]	9.40±0.10 [.370±.004]	FSM14JSML	1-1571563-0
		100,000	WHITE	NYLON	260G±50G	12MM	24MM	9.50±0.10 [.374±.004]	5.89±0.10 [.232±.004]	FSM8JSMAATR	1-1571563-4
OBSOLETE		100,000	WHITE	NYLON	260G±50G	-	-	9.50±0.10 [.374±.004]	5.89±0.10 [.232±.004]	FSM8JSMAA	1-1571563-3
		100,000	BLACK	PPS	160G±50G	12MM	24MM	9.50±0.10 [.374±.004]	5.89±0.10 [.232±.004]	FSM8JSMATR	1571563-9
		100,000	BLACK	PPS	160G±50G	-	-	9.50±0.10 [.374±.004]	5.89±0.10 [.232±.004]	FSM8JSMA	3-1437566-8
OBSOLETE		100,000	WHITE	NYLON	260G±50G	12MM	24MM	7.01±0.10 [.276±.004]	3.40±0.10 [.134±.004]	FSM6JSMAATR	1-1571563-2
OBSOLETE		100,000	WHITE	NYLON	260G±50G	-	-	7.01±0.10 [.276±.004]	3.40±0.10 [.134±.004]	FSM6JSMAA	1-1571563-1
		100,000	BLACK	PPS	160G±50G	12MM	24MM	7.01±0.10 [.276±.004]	3.40±0.10 [.134±.004]	FSM6JSMATR	5-1437565-0
		100,000	BLACK	PPS	160G±50G	-	-	7.01±0.10 [.276±.004]	3.40±0.10 [.134±.004]	FSM6JSMA	4-1437565-9
		1,000,000	VIOLET	NYLON	70G±30G	12MM	16MM	4.98±0.25 [.196±.010]	1.40±0.10 [.055±.004]	FSM4JSMXLTR	1571563-2
		1,000,000	VIOLET	NYLON	70G±30G	-	-	4.98±0.25 [.196±.010]	1.40±0.10 [.055±.004]	FSM4JSMXL	1571563-1
		100,000	WHITE	NYLON	260G±50G	12MM	16MM	4.98±0.25 [.196±.010]	1.40±0.10 [.055±.004]	FSM4JSMAATR	1571563-4
OBSOLETE		100,000	WHITE	NYLON	260G±50G	-	-	4.98±0.25 [.196±.010]	1.40±0.10 [.055±.004]	FSM4JSMAA	1571563-3
		100,000	BLACK	PPS	160G±50G	12MM	16MM	4.98±0.25 [.196±.010]	1.40±0.10 [.055±.004]	FSM4JSMATR	4-1437565-2
		100,000	BLACK	PPS	160G±50G	-	-	4.98±0.25 [.196±.010]	1.40±0.10 [.055±.004]	FSM4JSMA	4-1437565-1
		1,000,000	BLUE	NYLON	100G±30G	12MM	16MM	4.98±0.25 [.196±.010]	1.40±0.10 [.055±.004]	FSM4JSMLSTR	1571563-8
		1,000,000	BLUE	NYLON	100G±30G	-	-	4.98±0.25 [.196±.010]	1.40±0.10 [.055±.004]	FSM4JSMLS	1571563-7
		100,000	WHITE	NYLON	260G±50G	12MM	16MM	4.29±0.15 [.169±.006]	0.71±0.10 [.028±.004]	FSM2JSMAATR	2-1437565-9
		100,000	WHITE	NYLON	260G±50G	-	-	4.29±0.15 [.169±.006]	0.71±0.10 [.028±.004]	FSM2JSMAA	2-1437565-8
		100,000	GRAY	PPS	160G±50G	12MM	16MM	4.29±0.15 [.169±.006]	0.71±0.10 [.028±.004]	FSM2JSMATR	3-1437565-0
		100,000	GRAY	PPS	160G±50G	-	-	4.29±0.15 [.169±.006]	0.71±0.10 [.028±.004]	FSM2JSMA	2-1437565-7
		200,000	BROWN	PPS	100±50G	12MM	16MM	4.29±0.15 [.169±.006]	0.71±0.10 [.028±.004]	FSM2JSMLTR	1571527-2
		200,000	BROWN	PPS	100±50G	-	-	4.29±0.15 [.169±.006]	0.71±0.10 [.028±.004]	FSM2JSML	1571527-1
		LIFE CYCLE	ACTUATOR COLOR	ACTUATOR MATERIAL	ACTUATION FORCE	PITCH	TAPE WIDTH	DIM 'B'		DIM 'A'	
								T&B PART NUMBER		PART NUMBER	

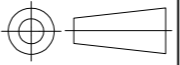
THIS DRAWING IS A CONTROLLED DOCUMENT.		DWN D.SARKISIAN 04MAY04	 TE Connectivity			
		CHK D.SARKISIAN 22APR94				
		APVD D.SARKISIAN 22APR94	NAME			
DIMENSIONS: mm [INCHES]		TOLERANCES UNLESS OTHERWISE SPECIFIED:	MICRO MINIATURE PUSHBUTTON SWITCH FSM JSM			
		0 PLC ± -	SIZE			
		1 PLC ± -	CAGE CODE			
		2 PLC ± 0.30[.012]	DRAWING NO			
		3 PLC ± -	RESTRICTED TO			
		4 PLC ± -	SCALE			
		ANGLES ± 1'	SHEET			
MATERIAL		FINISH	WEIGHT		REV	
			-		V	
CUSTOMER DRAWING			2-1437565-7			
			2 of 2			