

LM2623 General Purpose, Gated Oscillator Based, DC/DC Boost Converter

Check for Samples: [LM2623](#)

FEATURES

- Good Efficiency Over a Very Wide Load Range
- Very Low Output Voltage Ripple
- Small, Mini-SO-8 Package (Half the Footprint of Standard 8 pin SO Package)
- 1.09 mm Package Height
- Up to 2 MHz Switching Frequency
- .8V to 14V Operating Voltage
- 1.1V Start-up Voltage
- 1.24V - 14V Adjustable Output Voltage
- Up to 2A Load Current at low Output Voltages
- 0.17 Ω Internal MOSFET
- Up to 90% Regulator Efficiency
- 80 μ A Typical Operating Current (into V_{DD} pin of supply)

- <2.5 μ A Guaranteed Supply Current In Shutdown
- 4mm x 4mm Thermally Enhanced LLP Package Option

APPLICATIONS

- Cameras, Pagers and Cell Phones
- PDAs, Palmtop Computers, GPS devices
- White LED Drive, TFT or Scanned LCDs
- Flash Memory Programming
- Hand-Held Instruments
- 1, 2, 3 or 4 Cell Alkaline Systems
- 1, 2 or 3 Cell Lithium-ion Systems

DESCRIPTION

The LM2623 is a high efficiency, general purpose, step-up DC-DC switching regulator for battery-powered and low input voltage systems. It accepts an input voltage between .8 and 14 volts and converts it into a regulated output voltage between 1.24 and 14 volts. Efficiencies up to 90% are achievable with the LM2623.

In order to adapt to a number of applications, the LM2623 allows the designer to vary the output voltage, the operating frequency (300kHz to 2 MHz) and duty cycle (17% to 90%) to optimize the part's performance. The selected values can be fixed or can vary with battery voltage or input to output voltage ratio. The LM2623 uses a very simple, on/off regulation mode to produce good efficiency and stable operation over a wide operating range. It normally regulates by skipping switching cycles when it reaches the regulation limit (Pulse Frequency Modulation).

Note: Please read the "Non-Linear Effect" and "Choosing The Correct C3 Capacitor" sub-sections of the Design Procedure section of this data sheet, so that any challenges with designing with this part can be taken into account before a board design/layout is finalized.

For Alternative Solutions, See Also: LM2700, LM2622, LM2731, LM2733, and LM2621.



Please be aware that an important notice concerning availability, standard warranty, and use in critical applications of Texas Instruments semiconductor products and disclaimers thereto appears at the end of this data sheet.

All trademarks are the property of their respective owners.

Typical Application Circuit

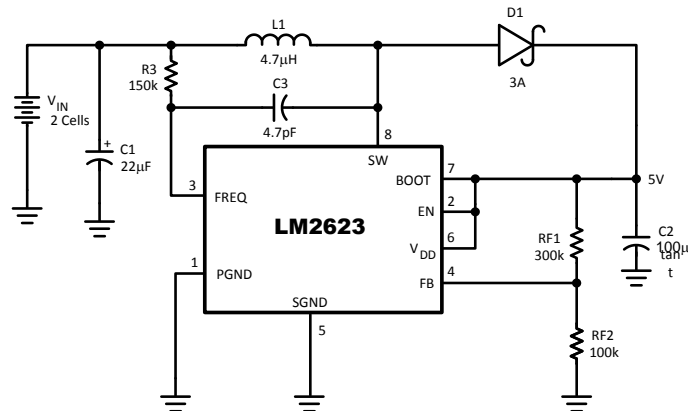

Connection Diagram

LLP Package

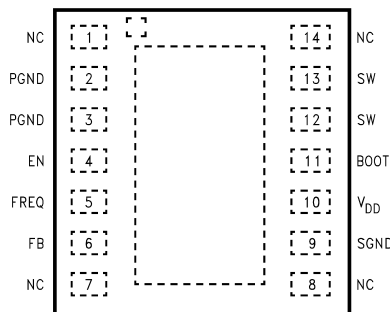

Figure 1. Top View

Mini SO-8 (MM) Package

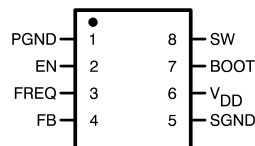

Figure 2. Top View

Pin Functions

Pin Description

LLP-14 Pin	MSOP-8 Pin	Name	Function
1		NC	No Connect
2, 3	1	PGND	Power Ground (LLP Pins 2 & 3 must be shorted together).
4	2	EN	Active-Low Shutdown Input
5	3	FREQ	Frequency Adjust. An external resistor connected between this pin and a voltage source sets the switching frequency of the LM2623.
6	4	FB	Output Voltage Feedback
7		NC	No Connect
8		NC	No connect
9	5	SGND	Signal Ground

Pin Description (continued)

LLP-14 Pin	MSOP-8 Pin	Name	Function
10	6	V _{DD}	Power Supply for Internal Circuitry
11	7	BOOT	Bootstrap Supply for the Gate Drive of Internal MOSFET Power Switch
12, 13	8	SW	Drain of the Internal MOSFET Power Switch. (LLP Pins 12 & 13 must be shorted together).
14		NC	No Connect
DAP		DAP	To be soldered to board for enhanced thermal dissipation. To be electrically isolated/floating.



These devices have limited built-in ESD protection. The leads should be shorted together or the device placed in conductive foam during storage or handling to prevent electrostatic damage to the MOS gates.

Absolute Maximum Ratings ⁽¹⁾

SW Pin Voltage	-0.5 V to 14.5V
BOOT, V _{DD} , EN and FB Pins	-0.5V to 10V
FREQ Pin	100μA
T _{Jmax} ⁽²⁾	150°C
Storage Temperature Range	-65°C to +150°C
Lead Temp. (Soldering, 5 sec)	260°C
Power Dissipation (T _A =25°C) ⁽²⁾	500mW
ESD Rating ⁽³⁾	2kV

- (1) Absolute maximum ratings indicate limits beyond which damage to the device may occur. Electrical specifications do not apply when operating the device outside of its rated operating conditions.
- (2) The maximum power dissipation must be derated at elevated temperatures and is dictated by T_{Jmax} (maximum junction temperature), θ_{JA} (junction to ambient thermal resistance), and T_A (ambient temperature). The maximum allowable power dissipation at any temperature is P_{dmax} = (T_{Jmax} - T_A) / θ_{JA} or the number given in the Absolute Maximum Ratings, whichever is lower.
- (3) The human body model is a 100 pF capacitor discharged through a 1.5 kΩ resistor into each pin. For Pin 8 (SW) the ESD rating is 1.0 kV.

Operating Conditions ⁽¹⁾

V _{DD} Pin	3V to 5V
FB, EN Pins	0 to V _{DD}
BOOT Pin	0 to 10V
Ambient Temperature (T _A)	-40°C to +85°C

- (1) Absolute maximum ratings indicate limits beyond which damage to the device may occur. Electrical specifications do not apply when operating the device outside of its rated operating conditions.

Electrical Characteristics

Limits in standard typeface are for $T_J = 25^\circ\text{C}$, and limits in **boldface** type apply over the full operating temperature range of -40°C to $+85^\circ\text{C}$. Unless otherwise specified: $V_{DD} = V_{OUT} = 3.3\text{V}$.

Symbol	Parameter	Condition	Typ	Min	Max	Units
V_{DD_ST}	Start-Up Supply Voltage 25°C	$I_{LOAD} = 0\text{mA}$ ⁽¹⁾			1.1	V
V_{IN_OP}	Minimum Operating Supply Voltage (once started)	$I_{LOAD} = 0\text{mA}$	0.65		.8	V
V_{FB}	FB Pin Voltage		1.24	1.2028	1.2772	V
V_{OUT_MAX}	Maximum Output Voltage		14			V
η	Efficiency	$V_{IN} = 3.6\text{V}; V_{OUT} = 5\text{V}; I_{LOAD} = 500\text{mA}$	87			%
		$V_{IN} = 2.5\text{V}; V_{OUT} = 3.3\text{V}; I_{LOAD} = 200\text{mA}$	87			
D	Switch Duty Cycle		17			%
I_{DD}	Operating Quiescent Current ⁽²⁾	FB Pin > 1.3V; EN Pin at V_{DD}	80		110	μA
I_{SD}	Shutdown Quiescent Current ⁽³⁾	V_{DD} , BOOT and SW Pins at 5.0V; EN Pin < 200mV	0.01		2.5	μA
I_{CL}	Switch Peak Current Limit	LM2623A	2.85	2.2		A
I_C	Switch Peak Current Limit	LM2623		1.2		A
R_{DS_ON}	MOSFET Switch On Resistance		0.17		0.26	Ω
θ_{JA}	Thermal Resistance	MM Package, Junction to Ambient ⁽⁴⁾	240			$^\circ\text{C/W}$
θ_{JA}	Thermal Resistance	LLP Package, Junction to Ambient ⁽⁴⁾ ⁽⁵⁾	40			$^\circ\text{C/W}$
θ_{JA}	Thermal Resistance	LLP Package, Junction to Ambient ⁽⁴⁾ ⁽⁶⁾	56			$^\circ\text{C/W}$
Enable Section						
V_{EN_LO}	EN Pin Voltage Low ⁽⁷⁾				0.15V_{DD}	V
V_{EN_HI}	EN Pin Voltage High ⁽⁷⁾			0.7V_{DD}		V

- (1) V_{DD} tied to Boot and EN pins. Frequency pin tied to V_{DD} through 121K resistor. $V_{DD_ST} = V_{DD}$ when start-up occurs. V_{IN} is $V_{DD} + D1$ voltage (usually 10-50 mV at start-up)
- (2) This is the current into the V_{DD} pin.
- (3) This is the total current into pins V_{DD} , BOOT, SW and FREQ.
- (4) The maximum power dissipation must be derated at elevated temperatures and is dictated by T_{jmax} (maximum junction temperature), θ_{JA} (junction to ambient thermal resistance), and T_A (ambient temperature). The maximum allowable power dissipation at any temperature is $P_{dmax} = (T_{jmax} - T_A) / \theta_{JA}$ or the number given in the Absolute Maximum Ratings, whichever is lower.
- (5) Junction to ambient thermal resistance (θ_{JA}) is taken from a thermal modeling result, performed under the conditions and guidelines set forth in the JEDEC standard JESD51-17. The test board is a 4 layer FR-4 board measuring 102mm x 76mm x 1.6mm with a 3 x 2 array of thermal vias. The ground plane on the board is 50mm x 50 mm. Thickness of copper layers are 36mm/18mm/18mm/36mm (1.5oz/10z/1oz/1.5oz). Ambient temperature in simulation is 22°C , still air. Power dissipation is 1W. (The DAP is soldered.) For more information on LLP thermal topics, as well as LLP mounting and soldering specifications please refer to **Application Note 1187: Leadless Leadframe Package (LLP)**.
- (6) Exposed DAP soldered to an exposed 1sq. inch area of 1 oz. copper. Thermal resistance can be decreased by using more copper are to dissipate heat.
- (7) When the EN pin is below V_{EN_LO} , the regulator is shut down; when it is above V_{EN_HI} , the regulator is operating.

Typical Performance Characteristics

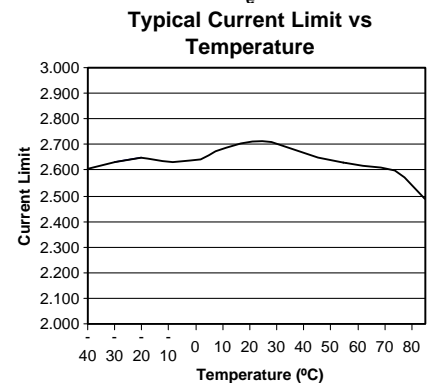
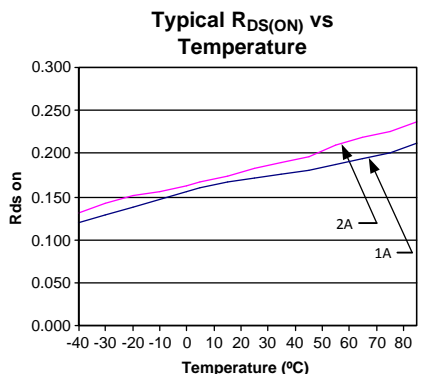
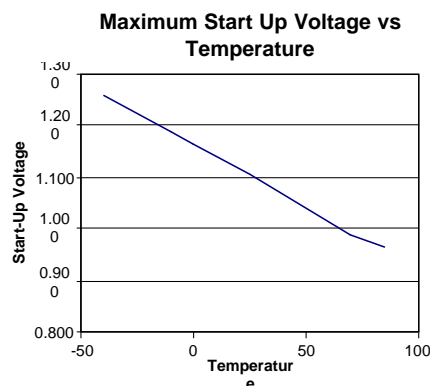
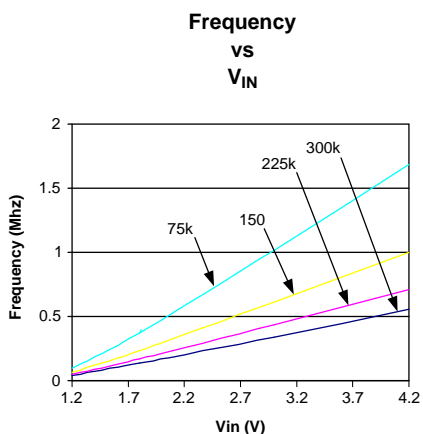
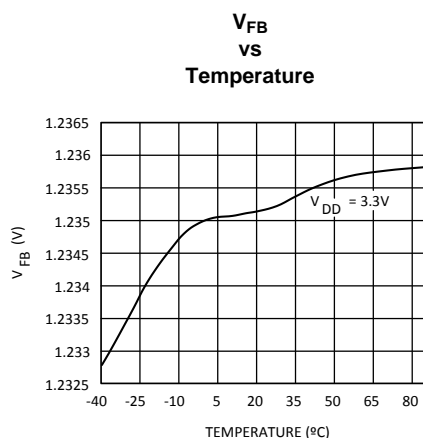
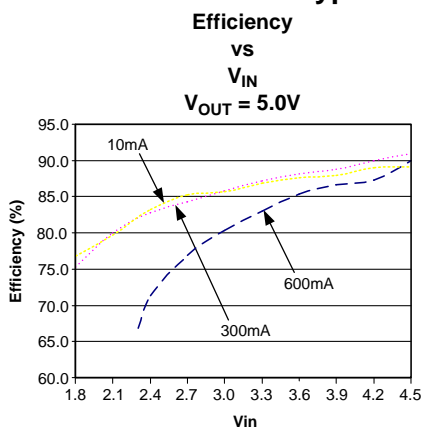

Detailed Description

OPERATING PRINCIPLE

The LM2623 is designed to provide step-up DC-DC voltage regulation in battery-powered and low-input voltage systems. It combines a step-up switching regulator, N-channel power MOSFET, built-in current limit, thermal limit, and voltage reference in a single 8-pin MSOP package [Figure 3](#). The switching DC-DC regulator boosts an input voltage between .8V and 14V to a regulated output voltage between 1.24V and 14V. The LM2623 starts from a low 1.1V input and remains operational down to below .8V.

This device is optimized for use in cellular phones and other applications requiring a small size, low profile, as well as low quiescent current for maximum battery life during stand-by and shutdown. A high-efficiency gated-oscillator topology offers an output of up to 2A at low output voltages.

Additional features include a built-in peak switch current limit, and thermal protection circuitry.

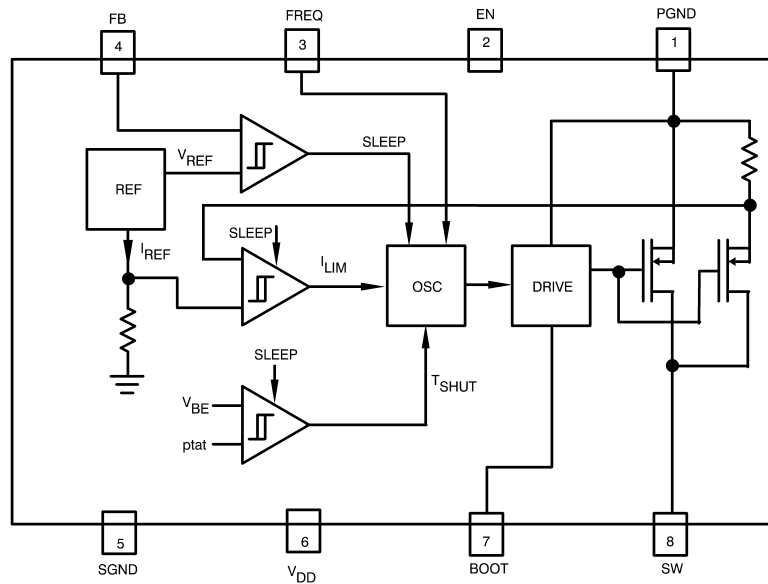

Figure 3. Functional Diagram

GATED OSCILLATOR CONTROL SCHEME

The on/off regulation mode of the LM2623, along with its ultra-low quiescent current, results in good efficiency over a very wide load range. The internal oscillator frequency can be programmed using an external resistor to be constant or vary with the battery voltage. Adding a capacitor to program the frequency allows the designer to adjust the duty cycle and optimize it for the application. Adding a resistor in addition to the capacitor allows the duty cycle to dynamically compensate for changes to the input/output voltage ratio. We call this a Ratio Adaptive Gated Oscillator circuit. See the Application Notes for sample application circuits. Using the correct RC components to adjust the oscillator allows the part to run with low ripple and high efficiency over a wide range of loads and input/output voltages.

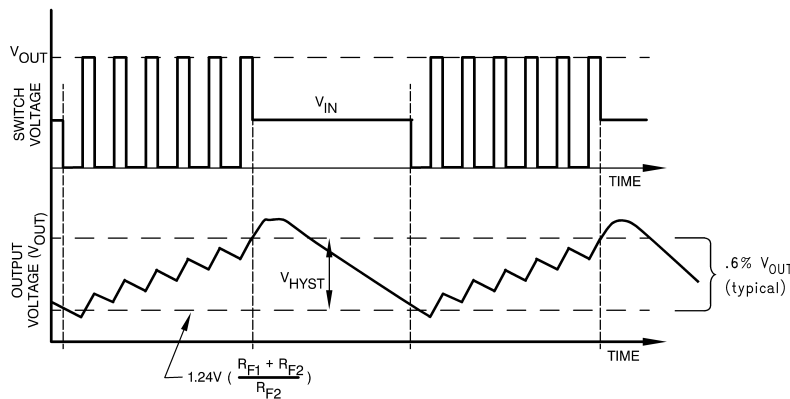

Figure 4. Typical Step-Up Regulator Waveforms

PULSE FREQUENCY MODULATION (PFM)

Pulse Frequency Modulation is typically accomplished by switching continuously until the voltage limit is reached and skipping cycles after that to just maintain it. This results in a somewhat hysteretic mode of operation. The coil stores more energy each cycle as the current ramps up to high levels. When the voltage limit is reached, the system usually overshoots to a higher voltage than required, due to the stored energy in the coil (see figure 2). The system will also undershoot somewhat when it starts switching again because it has depleted all the stored energy in the coil and needs to store more energy to reach equilibrium with the load. Larger output capacitors

and smaller inductors reduce the ripple in these situations. The frequency being filtered, however, is not the basic switching frequency. It is a lower frequency determined by the load, the input/output voltage and the circuit parameters. This mode of operation is useful in situations where the load variation is significant. Power managed computer systems, for instance, may vary from zero to full load while the system is on and this is usually the preferred regulation mode for such systems.

CYCLE TO CYCLE PFM

When the load doesn't vary over a wide range (like zero to full load), ratio adaptive circuit techniques can be used to achieve cycle to cycle PFM regulation and lower ripple (or smaller output capacitors). The key to success here is matching the duty cycle of the circuit closely to what is required by the input to output voltage ratio. This ratio then needs to be dynamically adjusted for input voltage changes (usually caused by batteries running down). The chosen ratio should allow most of the energy in each switching cycle to be delivered to the load and only a small amount to be stored. When the regulation limit is reached, the overshoot will be small and the system will settle at an equilibrium point where it adjusts the off time in each switching cycle to meet the current requirements of the load. The off time adjustment is done by exceeding the regulation limit during each switching cycle and waiting until the voltage drops below the limit again to start the next switching cycle. The current in the coil never goes to zero like it frequently does in the hysteretic operating mode of circuits with wide load variations or duty cycles that aren't matched to the input/output voltage ratio. Optimizing the duty cycle for a given set of input/output voltages conditions can be done by using the circuit values in the Application Notes.

LOW VOLTAGE START-UP

The LM2623 can start-up from voltages as low as 1.1 volts. On start-up, the control circuitry switches the N-channel MOSFET continuously until the output reaches 3 volts. After this output voltage is reached, the normal step-up regulator feedback and gated oscillator control scheme take over. Once the device is in regulation, it can operate down to below .8V input, since the internal power for the IC can be boot-strapped from the output using the V_{dd} pin.

SHUT DOWN

The LM2623 features a shutdown mode that reduces the quiescent current to less than a guaranteed 2.5uA over temperature. This extends the life of the battery in battery powered applications. During shutdown, all feedback and control circuitry is turned off. The regulator's output voltage drops to one diode drop below the input voltage. Entry into the shutdown mode is controlled by the active-low logic input pin EN (pinh- 2). When the logic input to this pin is pulled below .15V_{dd}, the device goes into shutdown mode. The logic input to this pin should be above .7V_{dd} for the device to work in normal stepup mode.

INTERNAL CURRENT LIMIT AND THERMAL PROTECTION

An internal cycle-by-cycle current limit serves as a protection feature. This is set high enough (2.85A typical, approximately 4A maximum) so as not to come into effect during normal operating conditions. An internal thermal protection circuit disables the MOSFET power switch when the junction temperature (T_J) exceeds about 160°C. The switch is re-enabled when T_J drops below approximately 135°C.

Design Procedure

NON-LINEAR EFFECT

The LM2623 is very similar to the LM2621. The LM2623 is based on the LM2621, except for the fact that the LM2623 takes advantage of a non-linear effect that allows for the duty cycle to be programmable. The C3 capacitor is used to dump charge on the FREQ pin in order to manipulate the duty cycle of the internal oscillator. The part is being tricked to behave in a certain manner, in the effort to make this Pulse Frequency Modulated (PFM) boost switching regulator behave as a Pulse Width Modulated (PWM) boost switching regulator.

CHOOSING THE CORRECT C3 CAPACITOR

The C3 capacitor allows for the duty cycle of the internal oscillator to be programmable. Choosing the correct C3 capacitor to get the appropriate duty cycle for a particular application circuit is a trial and error process. The non-linear effect that C3 produces is dependent on the input voltage and output voltage values. The correct C3 capacitor for particular input and output voltage values cannot be calculated. Choosing the correct C3 capacitance is best done by trial and error, in conjunction with the checking of the inductor peak current to make sure your not too close to the current limit of the device. As the C3 capacitor value increases, so does the duty cycle. And conversely as the C3 capacitor value decreases, the duty cycle decreases. An incorrect choice of the C3 capacitor can result in the part prematurely tripping the current limit and/or double pulsing, which could lead to the output voltage not being stable.

SETTING THE OUTPUT VOLTAGE

The output voltage of the step-up regulator can be set by connecting a feedback resistive divider made of R_{F1} and R_{F2} . The resistor values are selected as follows:

$$R_{F1} = R_{F2} * [(V_{OUT}/ 1.24) - 1] \quad (1)$$

A value of 50k to 100k is suggested for R_{F2} . Then, R_{F1} can be selected using the above equation.

V_{DD} SUPPLY

The V_{DD} supply must be between 3 to 5 volts for the LM2623. This voltage can be bootstrapped from a much lower input voltage by simply connecting the V_{DD} pin to V_{OUT}. In the event that the V_{DD} supply voltage is not a low ripple voltage source (less than 200 millivolts), it may be advisable to use an RC filter to clean it up. Excessive ripple on V_{DD} may reduce the efficiency.

SETTING THE SWITCHING FREQUENCY

The switching frequency of the oscillator is selected by choosing an external resistor (R3) connected between V_{IN} and the FREQ pin. See the graph titled "Frequency vs V_{IN}" in the Typical Performance Characteristics section of the data sheet for choosing the R3 value to achieve the desired switching frequency. A high switching frequency allows the use of very small surface mount inductors and capacitors and results in a very small solution size. A switching frequency between 300kHz and 2MHz is recommended.

OUTPUT DIODE SELECTION

A Schottky diode should be used for the output diode. The forward current rating of the diode should be higher than the peak input current, and the reverse voltage rating must be higher than the output voltage. Do not use ordinary rectifier diodes, since slow switching speeds and long recovery times cause the efficiency and the load regulation to suffer. [Table 1](#) shows a list of the diode manufacturers.

LLP PACKAGE DEVICES

The LM2623 is offered in the 14 lead LLP surface mount package to allow for increased power dissipation compared to the MSOP-8. For details of the thermal performance as well as mounting and soldering specifications, refer to **Application Note AN-1187**.

Table 1. Suggested Manufacturers List

Inductors	Capacitors	Diodes
Coilcraft Tel: (800) 322-2645 Fax: (708) 639-1469	Sprague/ Vishay Tel: (207) 324-4140 Fax: (207) 324-7223	Motorola Tel: (800) 521-6274 Fax: (602) 244-6609
Coiltronics Tel: (407) 241-7876 Fax: (407) 241-9339	Kemet Tel: (864) 963-6300 Fax: (864) 963-6521	International Rectifier (IR) Tel: (310) 322-3331 Fax: (310) 322-3332
Pulse Engineering Tel: (619) 674-8100 Fax: (619) 674-8262	Nichicon Tel: (847) 843-7500 Fax: (847) 843-2798	General Semiconductor Tel: (516) 847-3222 Fax: (516) 847-3150

PACKAGING INFORMATION

Orderable Device	Status (1)	Package Type	Package Drawing	Pins	Package Qty	Eco Plan (2)	Lead/Ball Finish	MSL Peak Temp (3)	Samples (Requires Login)
LM2623ALD	ACTIVE	WSON	NHE	14	1000	TBD	CU SNPB	Level-1-235C-UNLIM	
LM2623ALD/NOPB	ACTIVE	WSON	NHE	14	1000	Green (RoHS & no Sb/Br)	CU SN	Level-3-260C-168 HR	
LM2623AMM	ACTIVE	VSSOP	DGK	8	1000	TBD	CU SNPB	Level-1-260C-UNLIM	
LM2623AMM/NOPB	ACTIVE	VSSOP	DGK	8	1000	Green (RoHS & no Sb/Br)	CU SN	Level-1-260C-UNLIM	
LM2623AMMX	ACTIVE	VSSOP	DGK	8	3500	TBD	CU SNPB	Level-1-260C-UNLIM	
LM2623AMMX/NOPB	ACTIVE	VSSOP	DGK	8	3500	Green (RoHS & no Sb/Br)	CU SN	Level-1-260C-UNLIM	
LM2623LD	ACTIVE	WSON	NHE	14	1000	TBD	CU SNPB	Level-1-235C-UNLIM	
LM2623LD/NOPB	ACTIVE	WSON	NHE	14	1000	Green (RoHS & no Sb/Br)	CU SN	Level-3-260C-168 HR	
LM2623LDX	ACTIVE	WSON	NHE	14	4500	TBD	CU SNPB	Level-1-235C-UNLIM	
LM2623LDX/NOPB	ACTIVE	WSON	NHE	14	4500	Green (RoHS & no Sb/Br)	CU SN	Level-3-260C-168 HR	
LM2623MM	ACTIVE	VSSOP	DGK	8	1000	TBD	CU SNPB	Level-1-260C-UNLIM	
LM2623MM/NOPB	ACTIVE	VSSOP	DGK	8	1000	Green (RoHS & no Sb/Br)	CU SN	Level-1-260C-UNLIM	
LM2623MMX	ACTIVE	VSSOP	DGK	8	3500	TBD	CU SNPB	Level-1-260C-UNLIM	
LM2623MMX/NOPB	ACTIVE	VSSOP	DGK	8	3500	Green (RoHS & no Sb/Br)	CU SN	Level-1-260C-UNLIM	

(1) The marketing status values are defined as follows:

ACTIVE: Product device recommended for new designs.

LIFEBUY: TI has announced that the device will be discontinued, and a lifetime-buy period is in effect.

NRND: Not recommended for new designs. Device is in production to support existing customers, but TI does not recommend using this part in a new design.

PREVIEW: Device has been announced but is not in production. Samples may or may not be available.

OBSELETE: TI has discontinued the production of the device.

(2) Eco Plan - The planned eco-friendly classification: Pb-Free (RoHS), Pb-Free (RoHS Exempt), or Green (RoHS & no Sb/Br) - please check <http://www.ti.com/productcontent> for the latest availability information and additional product content details.

TBD: The Pb-Free/Green conversion plan has not been defined.

Pb-Free (RoHS): TI's terms "Lead-Free" or "Pb-Free" mean semiconductor products that are compatible with the current RoHS requirements for all 6 substances, including the requirement that lead not exceed 0.1% by weight in homogeneous materials. Where designed to be soldered at high temperatures, TI Pb-Free products are suitable for use in specified lead-free processes.

Pb-Free (RoHS Exempt): This component has a RoHS exemption for either 1) lead-based flip-chip solder bumps used between the die and package, or 2) lead-based die adhesive used between the die and leadframe. The component is otherwise considered Pb-Free (RoHS compatible) as defined above.

Green (RoHS & no Sb/Br): TI defines "Green" to mean Pb-Free (RoHS compatible), and free of Bromine (Br) and Antimony (Sb) based flame retardants (Br or Sb do not exceed 0.1% by weight in homogeneous material)

⁽³⁾ MSL, Peak Temp. -- The Moisture Sensitivity Level rating according to the JEDEC industry standard classifications, and peak solder temperature.

Important Information and Disclaimer:The information provided on this page represents TI's knowledge and belief as of the date that it is provided. TI bases its knowledge and belief on information provided by third parties, and makes no representation or warranty as to the accuracy of such information. Efforts are underway to better integrate information from third parties. TI has taken and continues to take reasonable steps to provide representative and accurate information but may not have conducted destructive testing or chemical analysis on incoming materials and chemicals. TI and TI suppliers consider certain information to be proprietary, and thus CAS numbers and other limited information may not be available for release.

In no event shall TI's liability arising out of such information exceed the total purchase price of the TI part(s) at issue in this document sold by TI to Customer on an annual basis.

TAPE AND REEL INFORMATION

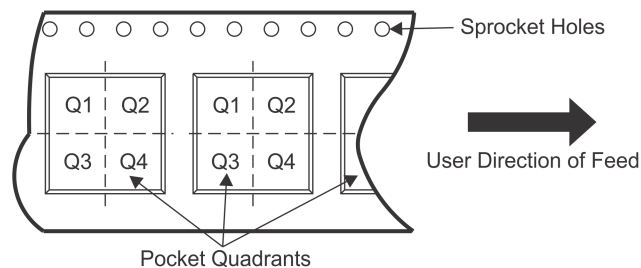
QUADRANT ASSIGNMENTS FOR PIN 1 ORIENTATION IN TAPE

*All dimensions are nominal

Device	Package Type	Package Drawing	Pins	SPQ	Reel Diameter (mm)	Reel Width W1 (mm)	A0 (mm)	B0 (mm)	K0 (mm)	P1 (mm)	W (mm)	Pin1 Quadrant
LM2623ALD	WSOP	NHE	14	1000	178.0	12.4	4.3	4.3	1.3	8.0	12.0	Q1
LM2623ALD/NOPB	WSOP	NHE	14	1000	178.0	12.4	4.3	4.3	1.3	8.0	12.0	Q1
LM2623AMM	VSSOP	DGK	8	1000	178.0	12.4	5.3	3.4	1.4	8.0	12.0	Q1
LM2623AMM/NOPB	VSSOP	DGK	8	1000	178.0	12.4	5.3	3.4	1.4	8.0	12.0	Q1
LM2623AMMX	VSSOP	DGK	8	3500	330.0	12.4	5.3	3.4	1.4	8.0	12.0	Q1
LM2623AMMX/NOPB	VSSOP	DGK	8	3500	330.0	12.4	5.3	3.4	1.4	8.0	12.0	Q1
LM2623LD	WSOP	NHE	14	1000	178.0	12.4	4.3	4.3	1.3	8.0	12.0	Q1
LM2623LD/NOPB	WSOP	NHE	14	1000	178.0	12.4	4.3	4.3	1.3	8.0	12.0	Q1
LM2623LDX	WSOP	NHE	14	4500	330.0	12.4	4.3	4.3	1.3	8.0	12.0	Q1
LM2623LDX/NOPB	WSOP	NHE	14	4500	330.0	12.4	4.3	4.3	1.3	8.0	12.0	Q1
LM2623MM	VSSOP	DGK	8	1000	178.0	12.4	5.3	3.4	1.4	8.0	12.0	Q1
LM2623MM/NOPB	VSSOP	DGK	8	1000	178.0	12.4	5.3	3.4	1.4	8.0	12.0	Q1
LM2623MMX	VSSOP	DGK	8	3500	330.0	12.4	5.3	3.4	1.4	8.0	12.0	Q1
LM2623MMX/NOPB	VSSOP	DGK	8	3500	330.0	12.4	5.3	3.4	1.4	8.0	12.0	Q1

TAPE AND REEL BOX DIMENSIONS

*All dimensions are nominal

Device	Package Type	Package Drawing	Pins	SPQ	Length (mm)	Width (mm)	Height (mm)
LM2623ALD	WSON	NHE	14	1000	203.0	190.0	41.0
LM2623ALD/NOPB	WSON	NHE	14	1000	203.0	190.0	41.0
LM2623AMM	VSSOP	DGK	8	1000	203.0	190.0	41.0
LM2623AMM/NOPB	VSSOP	DGK	8	1000	203.0	190.0	41.0
LM2623AMMX	VSSOP	DGK	8	3500	349.0	337.0	45.0
LM2623AMMX/NOPB	VSSOP	DGK	8	3500	349.0	337.0	45.0
LM2623LD	WSON	NHE	14	1000	203.0	190.0	41.0
LM2623LD/NOPB	WSON	NHE	14	1000	203.0	190.0	41.0
LM2623LDX	WSON	NHE	14	4500	349.0	337.0	45.0
LM2623LDX/NOPB	WSON	NHE	14	4500	358.0	343.0	63.0
LM2623MM	VSSOP	DGK	8	1000	203.0	190.0	41.0
LM2623MM/NOPB	VSSOP	DGK	8	1000	203.0	190.0	41.0
LM2623MMX	VSSOP	DGK	8	3500	349.0	337.0	45.0
LM2623MMX/NOPB	VSSOP	DGK	8	3500	349.0	337.0	45.0

DGK (S-PDSO-G8)

PLASTIC SMALL-OUTLINE PACKAGE

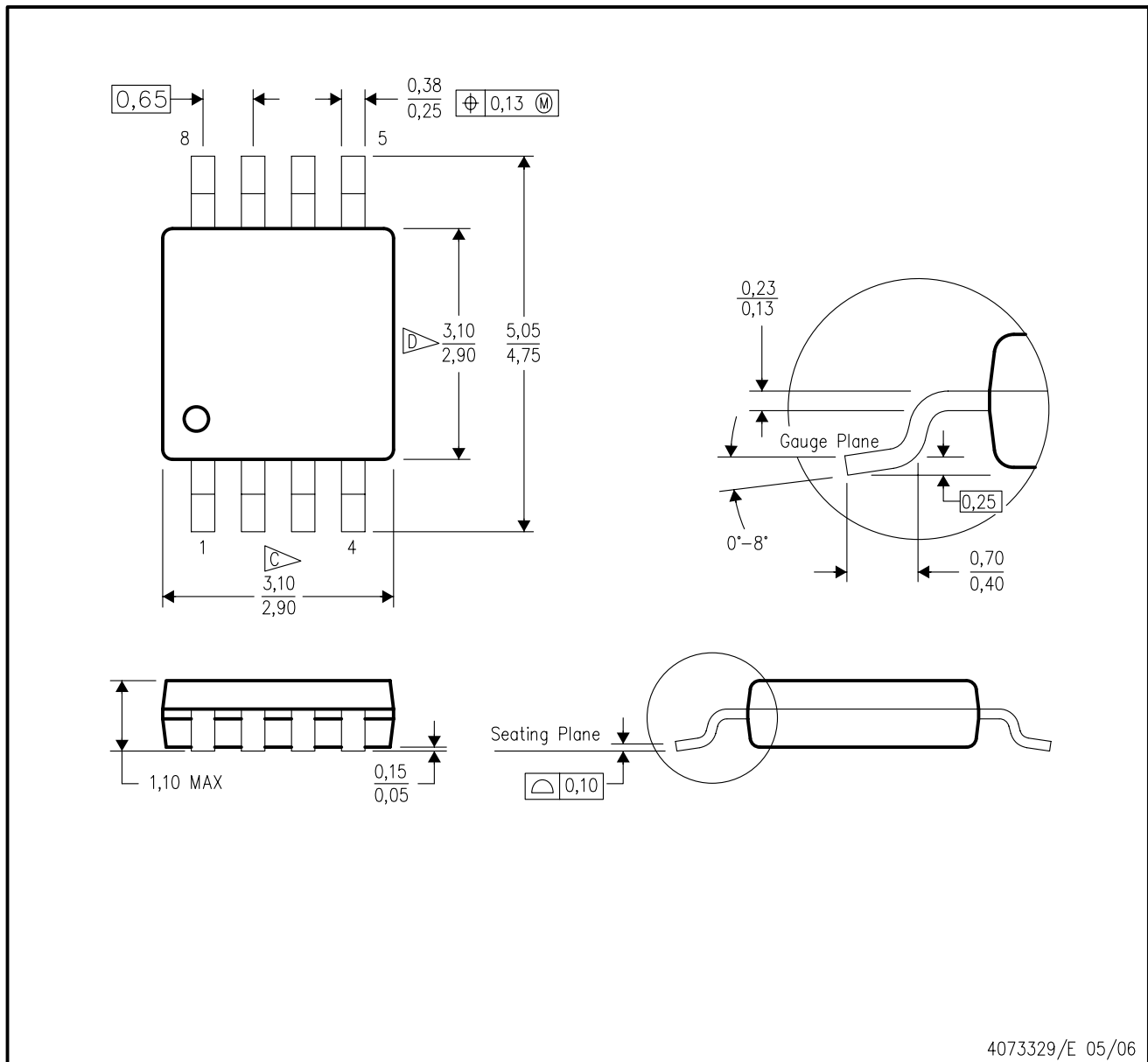

4073329/E 05/06

- NOTES:
- A. All linear dimensions are in millimeters.
 - B. This drawing is subject to change without notice.
 - C. Body length does not include mold flash, protrusions, or gate burrs. Mold flash, protrusions, or gate burrs shall not exceed 0.15 per end.
 - D. Body width does not include interlead flash. Interlead flash shall not exceed 0.50 per side.
 - E. Falls within JEDEC MO-187 variation AA, except interlead flash.

NHE0014A

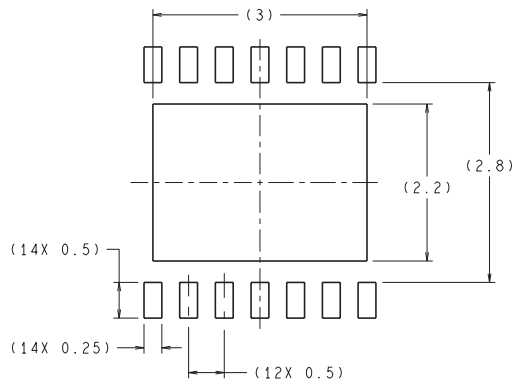

RECOMMENDED LAND PATTERN
1:1 RATION WITH PKG SOLDER PADS

DIMENSIONS ARE IN MILLIMETERS

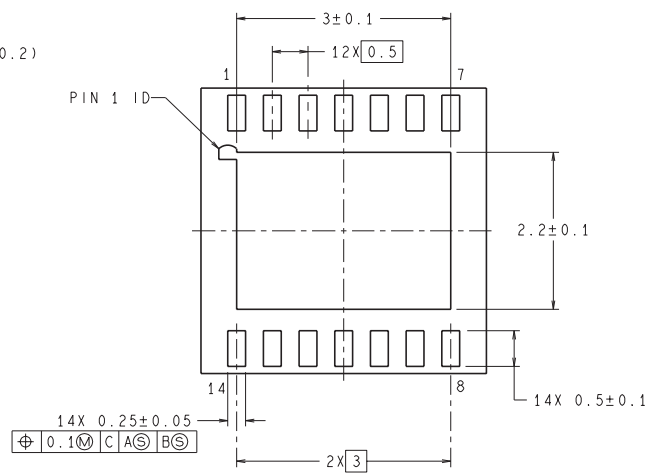
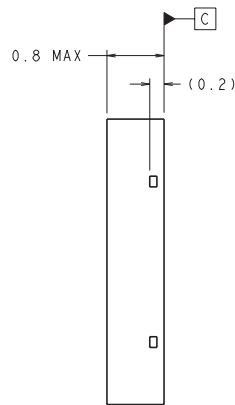
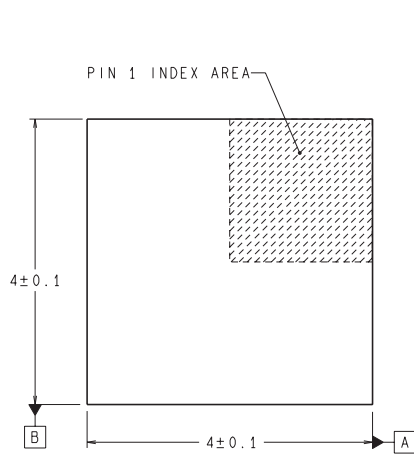

LDA14A (REV A)

IMPORTANT NOTICE

Texas Instruments Incorporated and its subsidiaries (TI) reserve the right to make corrections, enhancements, improvements and other changes to its semiconductor products and services per JESD46, latest issue, and to discontinue any product or service per JESD48, latest issue. Buyers should obtain the latest relevant information before placing orders and should verify that such information is current and complete. All semiconductor products (also referred to herein as "components") are sold subject to TI's terms and conditions of sale supplied at the time of order acknowledgment.

TI warrants performance of its components to the specifications applicable at the time of sale, in accordance with the warranty in TI's terms and conditions of sale of semiconductor products. Testing and other quality control techniques are used to the extent TI deems necessary to support this warranty. Except where mandated by applicable law, testing of all parameters of each component is not necessarily performed.

TI assumes no liability for applications assistance or the design of Buyers' products. Buyers are responsible for their products and applications using TI components. To minimize the risks associated with Buyers' products and applications, Buyers should provide adequate design and operating safeguards.

TI does not warrant or represent that any license, either express or implied, is granted under any patent right, copyright, mask work right, or other intellectual property right relating to any combination, machine, or process in which TI components or services are used. Information published by TI regarding third-party products or services does not constitute a license to use such products or services or a warranty or endorsement thereof. Use of such information may require a license from a third party under the patents or other intellectual property of the third party, or a license from TI under the patents or other intellectual property of TI.

Reproduction of significant portions of TI information in TI data books or data sheets is permissible only if reproduction is without alteration and is accompanied by all associated warranties, conditions, limitations, and notices. TI is not responsible or liable for such altered documentation. Information of third parties may be subject to additional restrictions.

Resale of TI components or services with statements different from or beyond the parameters stated by TI for that component or service voids all express and any implied warranties for the associated TI component or service and is an unfair and deceptive business practice. TI is not responsible or liable for any such statements.

Buyer acknowledges and agrees that it is solely responsible for compliance with all legal, regulatory and safety-related requirements concerning its products, and any use of TI components in its applications, notwithstanding any applications-related information or support that may be provided by TI. Buyer represents and agrees that it has all the necessary expertise to create and implement safeguards which anticipate dangerous consequences of failures, monitor failures and their consequences, lessen the likelihood of failures that might cause harm and take appropriate remedial actions. Buyer will fully indemnify TI and its representatives against any damages arising out of the use of any TI components in safety-critical applications.

In some cases, TI components may be promoted specifically to facilitate safety-related applications. With such components, TI's goal is to help enable customers to design and create their own end-product solutions that meet applicable functional safety standards and requirements. Nonetheless, such components are subject to these terms.

No TI components are authorized for use in FDA Class III (or similar life-critical medical equipment) unless authorized officers of the parties have executed a special agreement specifically governing such use.

Only those TI components which TI has specifically designated as military grade or "enhanced plastic" are designed and intended for use in military/aerospace applications or environments. Buyer acknowledges and agrees that any military or aerospace use of TI components which have **not** been so designated is solely at the Buyer's risk, and that Buyer is solely responsible for compliance with all legal and regulatory requirements in connection with such use.

TI has specifically designated certain components as meeting ISO/TS16949 requirements, mainly for automotive use. In any case of use of non-designated products, TI will not be responsible for any failure to meet ISO/TS16949.

Products

Audio	www.ti.com/audio
Amplifiers	amplifier.ti.com
Data Converters	dataconverter.ti.com
DLP® Products	www.dlp.com
DSP	dsp.ti.com
Clocks and Timers	www.ti.com/clocks
Interface	interface.ti.com
Logic	logic.ti.com
Power Mgmt	power.ti.com
Microcontrollers	microcontroller.ti.com
RFID	www.ti-rfid.com
OMAP Applications Processors	www.ti.com/omap
Wireless Connectivity	www.ti.com/wirelessconnectivity

Applications

Automotive and Transportation	www.ti.com/automotive
Communications and Telecom	www.ti.com/communications
Computers and Peripherals	www.ti.com/computers
Consumer Electronics	www.ti.com/consumer-apps
Energy and Lighting	www.ti.com/energy
Industrial	www.ti.com/industrial
Medical	www.ti.com/medical
Security	www.ti.com/security
Space, Avionics and Defense	www.ti.com/space-avionics-defense
Video and Imaging	www.ti.com/video

TI E2E Community

e2e.ti.com