



2K x 16 Dual-Port Static RAM

Features

- True dual-ported memory cells which allow simultaneous reads of the same memory location
- 2K x 16 organization
- 0.65-micron CMOS for optimum speed/power
- High-speed access: 25/35/55 ns
- Low operating power: $I_{CC} = 150 \text{ mA (typ.)}$
- Fully asynchronous operation
- Master CY7C133 expands data bus width to 32 bits or more using slave CY7C143
- BUSY input flag on CY7C133; BUSY output flag on CY7C143
- Available in 68-pin PLCC
- Pin-compatible and functionally equivalent to IDT7133 and IDT7143

Functional Description

The CY7C133 and CY7C143 are high-speed CMOS 2K by 16 dual-port static RAMs. Two ports are provided permitting independent access to any location in memory. The CY7C133 can be utilized as either a stand-alone 16-bit dual-port static RAM or as a master dual-port RAM in conjunction with the CY7C143 slave dual-port device in systems requiring 32-bit or greater word widths. It is the solution to applications requiring shared or buffered data, such as cache memory for DSP, bit-slice, or multiprocessor designs.

Each port has independent control pins; Chip Enable (\overline{CE}), Write Enable (R/\overline{W}_{UB} , R/\overline{W}_{LB}), and Output Enable (\overline{OE}). BUSY signals that the port is trying to access the same location currently being accessed by the other port. An automatic power-down feature is controlled independently on each port by the Chip Enable (\overline{CE}) pin.

The CY7C133 and CY7C143 are available in 68-pin PLCC.

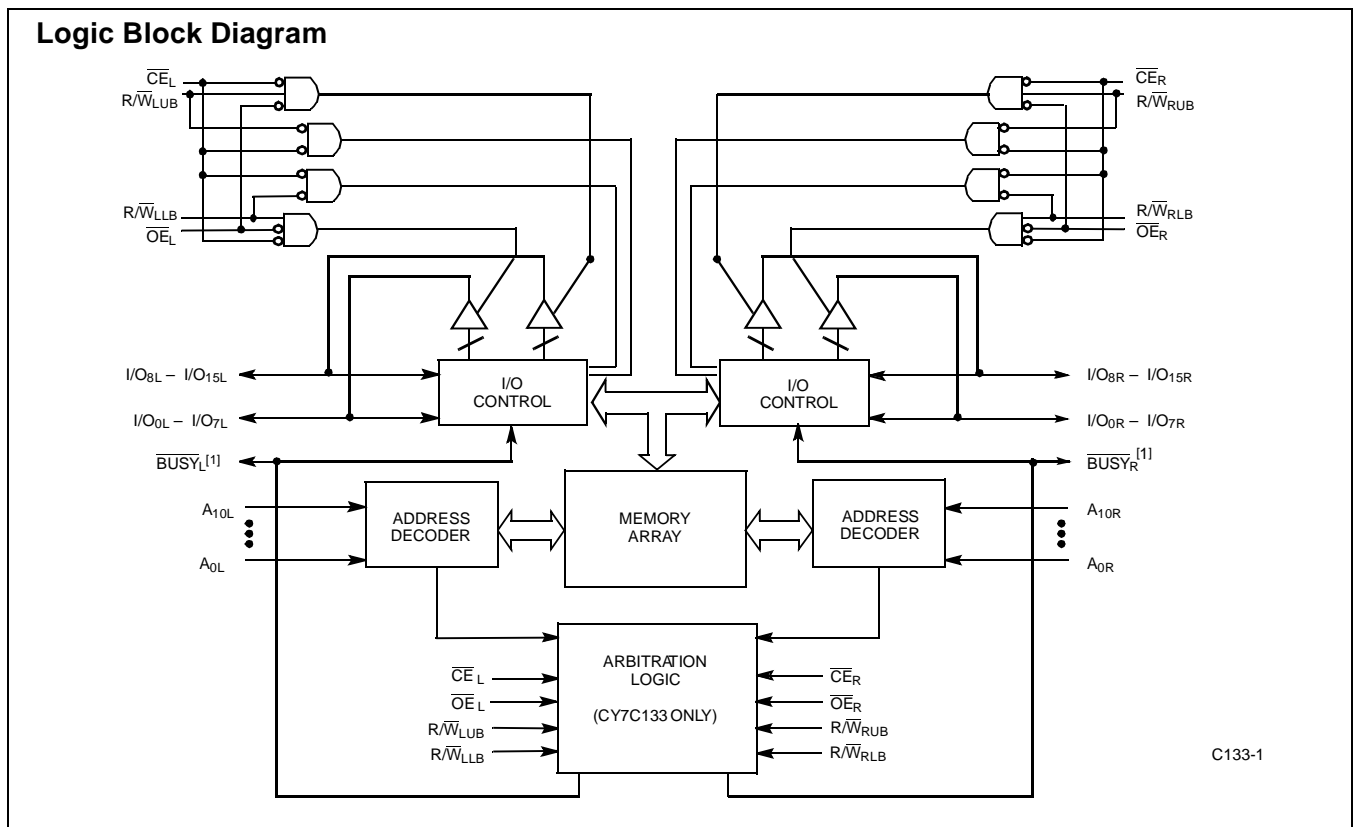

Note:

1. CY7C133 (Master): \overline{BUSY} is open drain output and requires pull-up resistor. CY7C143 (Slave): \overline{BUSY} is input.

Electrical Characteristics Over the Operating Range

Parameter	Description	Test Conditions	7C133-25 7C143-25			Unit
			Min.	Typ.	Max.	
V _{OH}	Output HIGH Voltage	V _{CC} = Min., I _{OH} = -4.0 mA	2.4			V
V _{OL}	Output LOW Voltage	I _{OL} = 4.0 mA			0.4	V
		I _{OL} = 16.0 mA ^[2]			0.5	
V _{IH}	Input HIGH Voltage		2.2			V
V _{IL}	Input LOW Voltage				0.8	V
I _{IX}	Input Leakage Current	GND ≤ V _I ≤ V _{CC}	-5		+5	μA
I _{OZ}	Output Leakage Current	GND ≤ V _O ≤ V _{CC} , Output Disabled	-5		+5	μA
I _{OS}	Output Short Circuit Current ^[3,4]	V _{CC} = Max., V _{OUT} = GND			-200	mA
I _{CC}	V _{CC} Operating Supply Current	$\overline{CE} = V_{IL}$, Outputs Open, f = f _{MAX} ^[5]	Com'l	170	250	mA
			Ind.	170	290	
I _{SB1}	Standby Current Both Ports, TTL Inputs	\overline{CE}_L and $\overline{CE}_R \geq V_{IH}$, f = f _{MAX} ^[5]	Com'l	40	60	mA
			Ind.	40	75	
I _{SB2}	Standby Current One Port, TTL Inputs	\overline{CE}_L or $\overline{CE}_R \geq V_{IH}$, Active Port Outputs Open, f = f _{MAX} ^[5]	Com'l	100	140	mA
			Ind.	100	160	
I _{SB3}	Standby Current Both Ports, CMOS Inputs	Both Ports \overline{CE}_L and $\overline{CE}_R \geq V_{CC} - 0.2V$, V _{IN} ≥ V _{CC} - 0.2V or V _{IN} ≤ 0.2V, f = 0	Com'l	3	15	mA
			Ind.	3	15	
I _{SB4}	Standby Current One Port, CMOS Inputs	One Port \overline{CE}_L or $\overline{CE}_R \geq V_{CC} - 0.2V$, V _{IN} ≥ V _{CC} - 0.2V or V _{IN} ≤ 0.2V, Active Port Outputs Open, f = f _{MAX} ^[5]	Com'l	90	120	mA
			Ind.	90	140	

Notes:

2. \overline{BUSY} pin only.
3. Duration of the short circuit should not exceed 30 seconds.
4. Tested initially and after any design or process changes that may affect these parameters.
5. At f=f_{MAX}, address and data inputs are cycling at the maximum frequency of read cycle of 1/t_{RC} and using AC Test Waveforms input levels of GND to 3V.

Electrical Characteristics Over the Operating Range (continued)

Parameter	Description	Test Conditions	7C133-35 7C143-35			7C133-55 7C143-55			Unit	
			Min.	Typ.	Max.	Min.	Typ.	Max.		
V _{OH}	Output HIGH Voltage	V _{CC} = Min., I _{OH} = -4.0 mA	2.4			2.4			V	
V _{OL}	Output LOW Voltage	I _{OL} = 4.0 mA			0.4			0.4	V	
		I _{OL} = 16.0 mA ^[2]			0.5			0.5		
V _{IH}	Input HIGH Voltage		2.2			2.2			V	
V _{IL}	Input LOW Voltage				0.8			0.8	V	
I _{Ix}	Input Leakage Current	GND ≤ V _I ≤ V _{CC}	-5		+5	-5		+5	μA	
I _{OZ}	Output Leakage Current	GND ≤ V _O ≤ V _{CC} , Output Disabled	-5		+5	-5		+5	μA	
I _{OS}	Output Short Circuit Current ^[3,4]	V _{CC} = Max., V _{OUT} = GND			-200			-200	mA	
I _{CC}	V _{CC} Operating Supply Current	$\overline{CE} = V_{IL}$, Outputs Open, f = f _{MAX} ^[5]	Com'l		160	230		150	220	mA
			Ind.		160	260		150	250	
I _{SB1}	Standby Current Both Ports, TTL Inputs	\overline{CE}_L and $\overline{CE}_R \geq V_{IH}$, f = f _{MAX} ^[5]	Com'l		30	50		20	40	mA
			Ind.		30	65		20	55	
I _{SB2}	Standby Current One Port, TTL Inputs	\overline{CE}_L or $\overline{CE}_R \geq V_{IH}$, Active Port Outputs Open, f = f _{MAX} ^[5]	Com'l		85	125		75	110	mA
			Ind.		85	140		75	125	
I _{SB3}	Standby Current Both Ports, CMOS Inputs	Both Ports \overline{CE}_L and $\overline{CE}_R \geq V_{CC} - 0.2V$, V _{IN} ≥ V _{CC} - 0.2V or V _{IN} ≤ 0.2V, f = 0	Com'l		3	15		3	15	mA
			Ind.		3	15		3	15	
I _{SB4}	Standby Current One Port, CMOS Inputs	One Port \overline{CE}_L or $\overline{CE}_R \geq V_{CC} - 0.2V$, V _{IN} ≥ V _{CC} - 0.2V or V _{IN} ≤ 0.2V, Active Port Outputs Open, f = f _{MAX} ^[5]	Com'l		80	105		70	90	mA
			Ind.		80	120		70	105	

Capacitance^[4]

Parameter	Description	Test Conditions	Max.	Unit
C _{IN}	Input Capacitance	T _A = 25°C, f = 1 MHz, V _{CC} = 5.0V	10	pF
C _{OUT}	Output Capacitance		10	pF

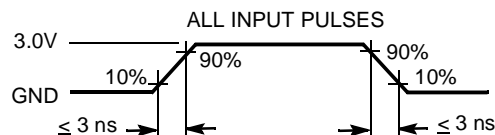
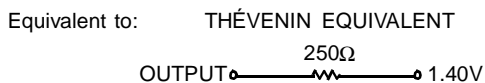
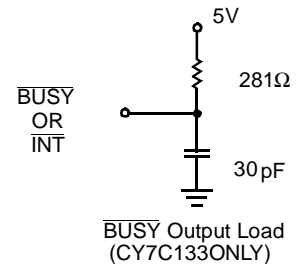
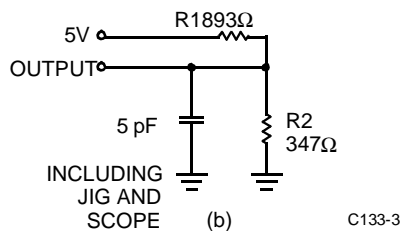
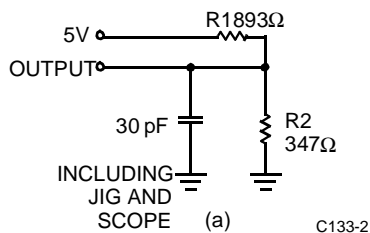
AC Test Loads and Waveforms

C133-4

Switching Characteristics Over the Operating Range^[6]

Parameter	Description	7C133-25 7C143-25		7C133-35 7C143-35		7C133-55 7C143-55		Unit
		Min.	Max.	Min.	Max.	Min.	Max.	
READ CYCLE								
t _{RC}	Read Cycle Time	25		35		55		ns
t _{AA}	Address to Data Valid ^[7]		25		35		55	ns
t _{OHA}	Data Hold from Address Change	0		0		0		ns
t _{ACE}	\overline{CE} LOW to Data Valid ^[7]		25		35		55	ns
t _{DOE}	\overline{OE} LOW to Data Valid ^[7]		20		25		30	ns
t _{LZOE}	\overline{OE} LOW to Low Z ^[8, 9, 10]	3		3		3		ns
t _{HZOE}	\overline{OE} HIGH to High Z ^[8, 9, 10]		15		20		25	ns
t _{LZCE}	\overline{CE} LOW to Low Z ^[8, 9, 10]	3		5		5		ns
t _{HZCE}	\overline{CE} HIGH to High Z ^[8, 9, 10]		15		20		20	ns
t _{PU}	\overline{CE} LOW to Power-Up ^[10]	0		0		0		ns
t _{PD}	\overline{CE} HIGH to Power-Down ^[10]		25		25		25	ns
WRITE CYCLE^[11]								
t _{WC}	Write Cycle Time	25		35		55		ns
t _{SCE}	\overline{CE} LOW to Write End	20		25		40		ns
t _{AW}	Address Set-Up to Write End	20		25		40		ns
t _{HA}	Address Hold from Write End	2		2		2		ns
t _{SA}	Address Set-Up to Write Start	0		0		0		ns
t _{PWE}	R \overline{W} Pulse Width	20		25		35		ns
t _{SD}	Data Set-Up to Write End	15		20		20		ns
t _{HD}	Data Hold from Write End	0		0		0		ns
t _{HZWE}	R \overline{W} LOW to High Z ^[9, 10]		15		20		20	ns
t _{LZWE}	R \overline{W} HIGH to Low Z ^[9, 10]	0		0		0		ns

Notes:

6. Test conditions assume signal transition times of 5 ns or less, timing reference levels of 1.5V, input pulse levels of 0 to 3.0V and output loading of the specified I_{OL}/I_{OH} and 30-pF load capacitance.
7. AC Test Conditions use V_{OH} = 1.6V and V_{OL} = 1.4V.
8. At any given temperature and voltage condition for any given device, t_{LZCE} is less than t_{HZCE} and t_{LZOE} is less than t_{HZOE}.
9. t_{LZCE}, t_{LZWE}, t_{HZOE}, t_{LZOE}, t_{HZCE} and t_{HZWE} are tested with C_L = 5 pF as in part (b) of AC Test Loads. Transition is measured ±500 mV from steady state voltage.
10. This parameter is guaranteed but not tested.
11. The internal write time of the memory is defined by the overlap of \overline{CS} LOW and R \overline{W} LOW. Both signals must be LOW to initiate a write and either signal can terminate a write by going HIGH. The data input set-up and hold timing should be referenced to the rising edge of the signal that terminates the write.

Switching Characteristics Over the Operating Range^[6] (continued)

Parameter	Description	7C133-25 7C143-25		7C133-35 7C143-35		7C133-55 7C143-55		Unit
		Min.	Max.	Min.	Max.	Min.	Max.	
BUSY/INTERRUPT TIMING (For Master CY7C133)								
t_{BLA}	\overline{BUSY} Low from Address Match		25		35		50	ns
t_{BHA}	\overline{BUSY} High from Address Mismatch		20		30		40	ns
t_{BLC}	\overline{BUSY} Low from \overline{CE} LOW		20		25		35	ns
t_{BHC}	\overline{BUSY} High from \overline{CE} HIGH		20		20		30	ns
t_{WDD}	Write Pulse to Data Delay ^[12]		50		60		80	ns
t_{DDD}	Write Data Valid to Read Data Valid ^[12]		35		45		55	ns
t_{BDD}	\overline{BUSY} High to Valid Data ^[13]		Note 13		Note 13		Note 13	ns
t_{PS}	Arbitration Priority Set Up Time ^[14]	5		5		5		ns
BUSY TIMING (For Slave CY7C143)								
t_{WB}	Write to \overline{BUSY} ^[15]	0		0		0		ns
t_{WH}	Write Hold After \overline{BUSY} ^[16]	20		25		30		ns
t_{WDD}	Write Pulse to Data Delay ^[17]		50		60		80	ns
t_{DDD}	Write Data Valid to Read Data Valid ^[17]		35		45		55	ns

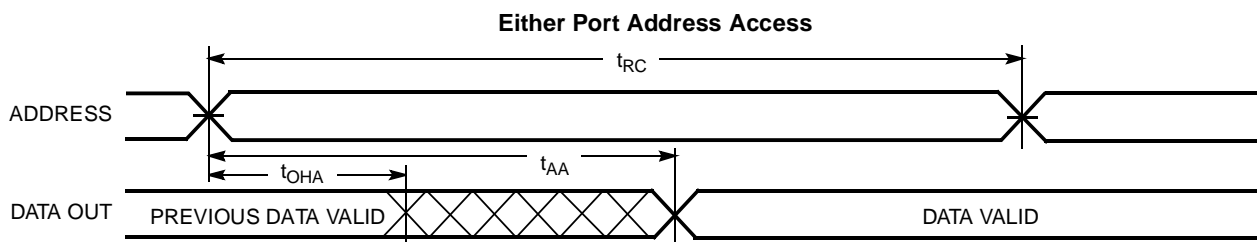
Switching Waveforms
Read Cycle No.1 ^[18, 19]

C133-5

Notes:

12. Port-to-port delay through RAM cells from writing port to reading port. Refer to timing waveform of "Read with \overline{BUSY} , Master: CY7C133."
13. t_{BDD} is a calculated parameter and is greater of $0, t_{WDD} - t_{WP}$ (actual) or $t_{DDD} - t_{DW}$ (actual).
14. To ensure that the earlier of the two ports wins.
15. To ensure that write cycle is inhibited during contention.
16. To ensure that a write cycle is completed after contention.
17. Port-to-port delay through RAM cells from writing port to reading port. Refer to timing waveform of "Read with Port-to-port Delay."
18. R/W is HIGH for read cycle.
19. Device is continuously selected, $\overline{CE} = V_{IL}$ and $\overline{OE} = V_{IL}$.

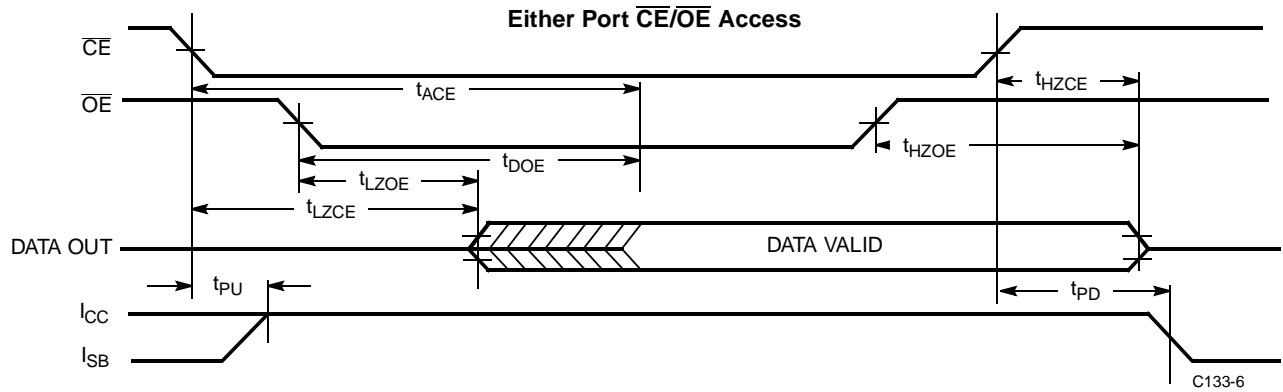
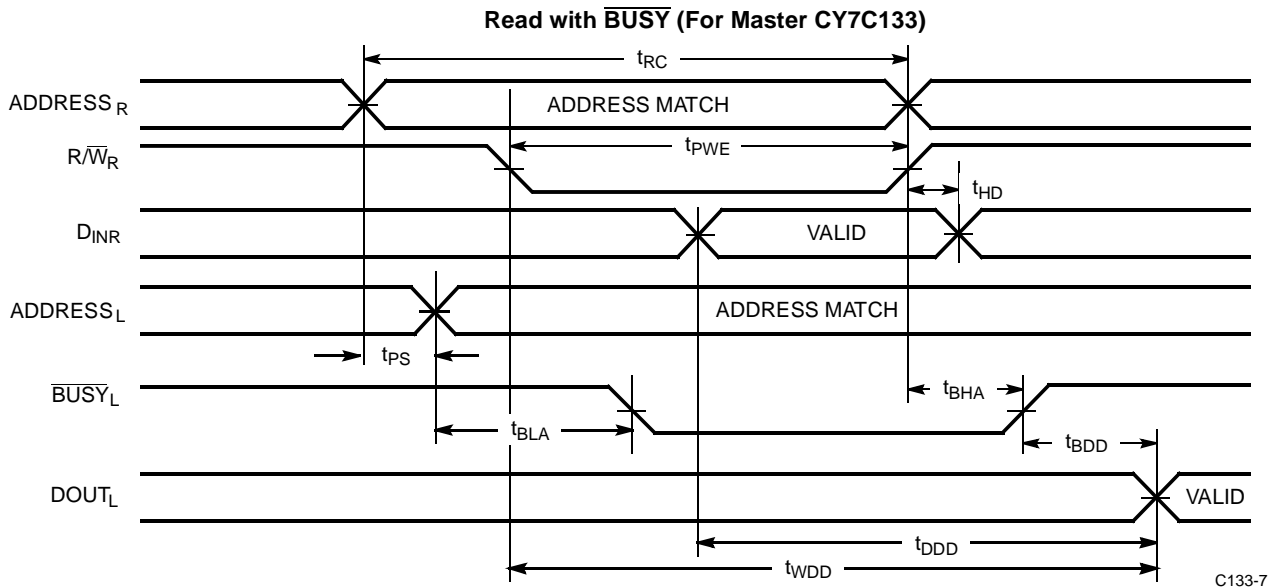
Switching Waveforms (continued)
Read Cycle No. 2 ^[18, 20]

Read Cycle No. 3 ^[19]

Note:
20. Address valid prior to or coincidence with \overline{CE} transition LOW.

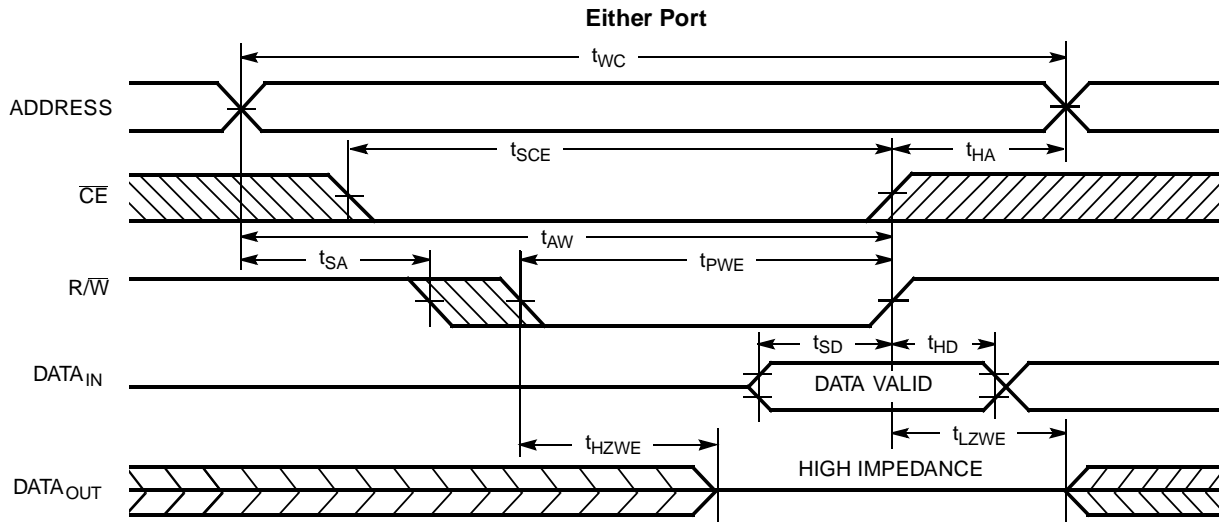
Switching Waveforms (continued)

Write Cycle No. 2 (R/W Three-States Data I/Os—Either Port) [20, 25]

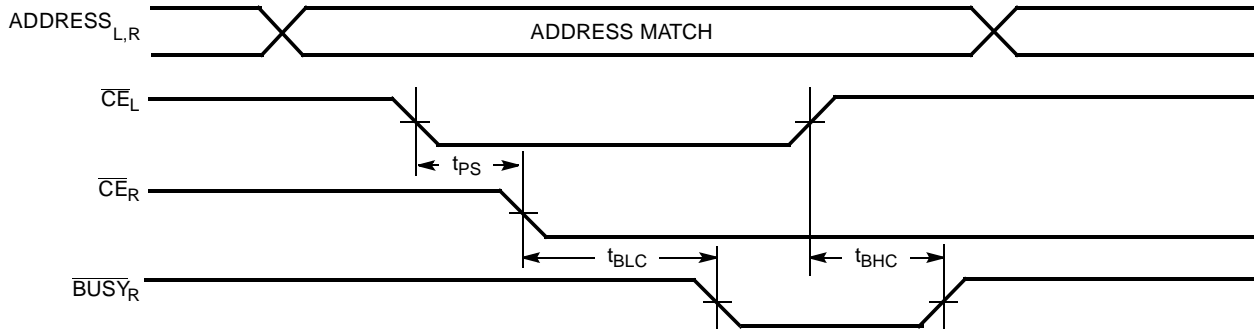
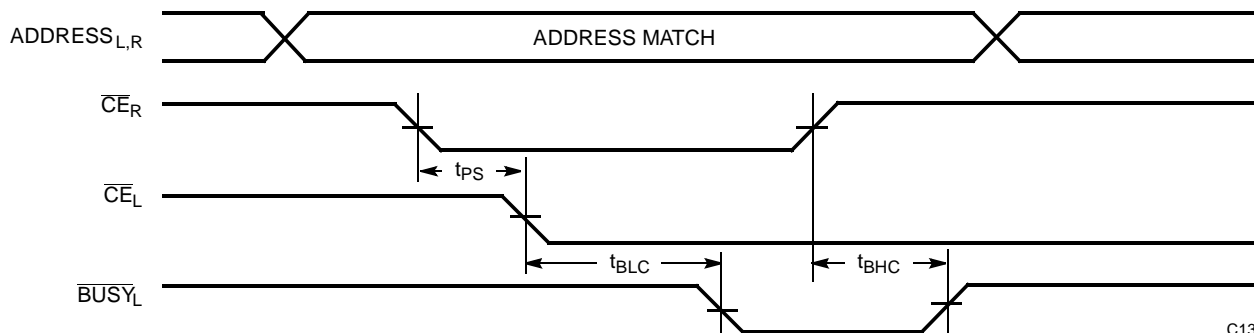
C133-10

Busy Timing Diagram No. 1 (\overline{CE} Arbitration)
 \overline{CE}_L Valid First:

 \overline{CE}_R Valid First:

C133-11

Note:

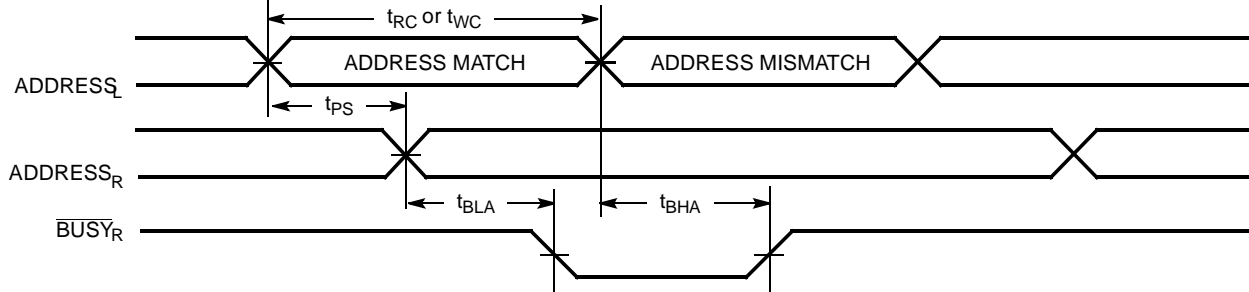
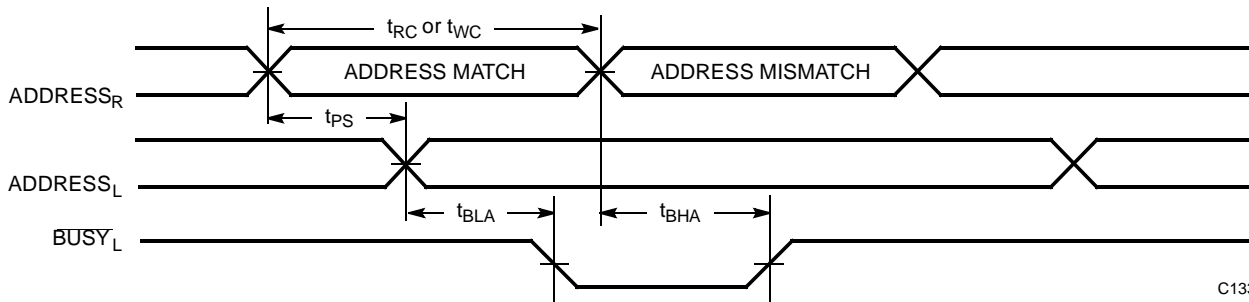
25. If the CE LOW transition occurs simultaneously with or after the R/W LOW transition, the outputs remain in the high-impedance state.

Switching Waveforms (continued)
Busy Timing Diagram No. 2 (Address Arbitration)
Left Address Valid First:

Right Address Valid First:

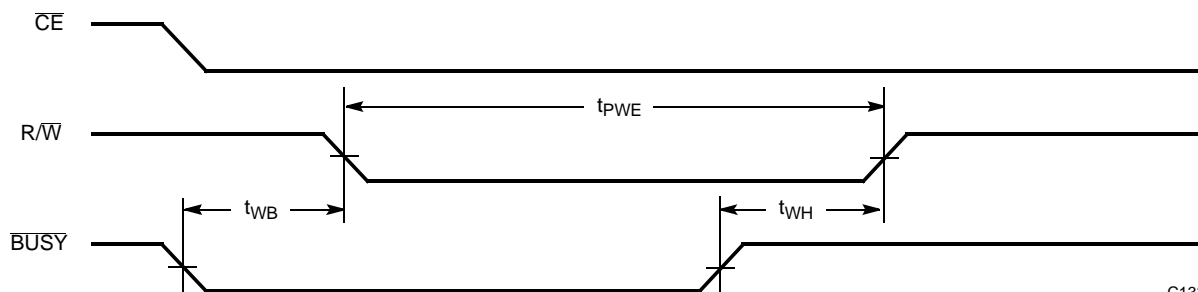
C133-12

Busy Timing Diagram No. 3
Write with $\overline{\text{BUSY}}$ (For Slave CY7C143)

C133-13

Architecture

The CY7C133 (master) and CY7C143 (slave) consist of an array of 2K words of 16 bits each of dual-port RAM cells, I/O and address lines, and control signals (\overline{CE} , \overline{OE} , R/\overline{W}). These control pins permit independent access for reads or writes to any location in memory. To handle simultaneous writes/reads to the same location, a \overline{BUSY} pin is provided on each port. The CY7C133 and CY7C143 have an automatic power-down feature controlled by \overline{CE} . Each port is provided with its own output enable control (\overline{OE}), which allows data to be read from the device.

Functional Description

Write Operation

Data must be set up for a duration of t_{SD} before the rising edge of R/\overline{W} in order to guarantee a valid write. A write operation is controlled by either the R/\overline{W} pin (see Write Cycle No. 1 waveform) or the \overline{CE} pin (see Write Cycle No. 2 waveform). Two R/\overline{W} pins (R/\overline{W}_{UB} and R/\overline{W}_{LB}) are used to separate the upper and lower bytes of IO. Required inputs for non-contention operations are summarized in Table 1.

If a location is being written to by one port and the opposite port attempts to read that location, a port-to-port flow-through delay must occur before the data is read on the output; otherwise the data read is not deterministic. Data will be valid on the port t_{DD} after the data is presented on the other port.

Read Operation

When reading the device, the user must assert both the \overline{OE} and \overline{CE} pins. Data will be available t_{ACE} after \overline{CE} or t_{DOE} after \overline{OE} is asserted.

Busy

The CY7C133 (master) provides on-chip arbitration to resolve simultaneous memory location access (contention). Table 2 shows a summary of conditions where \overline{BUSY} is asserted. If both ports' \overline{CE} s are asserted and an address match occurs within t_{PS} of each other, the busy logic will determine which port has access. If t_{PS} is violated, one port will definitely gain permission to the location, but which one is not predictable. \overline{BUSY} will be asserted t_{BLA} after an address match or t_{BLC} after \overline{CE} is taken LOW. The results of all eight arbitration possibilities are summarized in Table 3. \overline{BUSY} is an open drain output and requires a pull-up resistor.

One master and as many slaves as necessary may be connected in parallel to expand the data bus width in 16 bit increments. The \overline{BUSY} output of the master is connected to the \overline{BUSY}

input of the slave. Writing to slave devices must be delayed until after the \overline{BUSY} input has settled (t_{BLC} or t_{BLA}). Otherwise, the slave chip may begin a write cycle during a contention situation.

Flow-Through Operation

The CY7C133/143 has a flow-through architecture that facilitates repeating (actually extending) an operation when a \overline{BUSY} is received by a losing port. The \overline{BUSY} signal should be interpreted as a NOT READY. If a \overline{BUSY} to a port is active, the port should wait for \overline{BUSY} to go inactive, and then extend the operation it was performing for another cycle. The timing diagram titled, "Timing waveform with port to port delay" illustrates the case where the right port is writing to an address and the left port reads the same address. The data that the right port has just written flows through to the left, and is valid either t_{DD} after the falling edge of the write strobe of the left port, or t_{DD} after the data being written becomes stable.

Data Retention Mode

The CY7C133/143 is designed with battery backup in mind. Data retention voltage and supply current are guaranteed over temperature. The following rules insure data retention:

1. Chip enable (\overline{CE}) must be held HIGH during data retention, within V_{CC} to $V_{CC} - 0.2V$.
2. \overline{CE} must be kept between $V_{CC} - 0.2V$ and 70% of V_{CC} during the power-up and power-down transitions.
3. The RAM can begin operation $>t_{RC}$ after V_{CC} reaches the minimum operating voltage (4.5 volts).

Timing

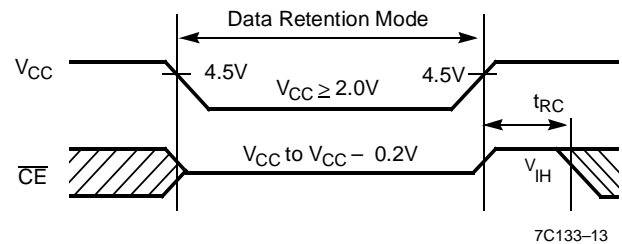

Parameter	Test Conditions ^[26]	Max.	Unit
I_{CCDR1}	@ $V_{CCDR} = 2V$	1.5	mA

Note:

26. $\overline{CE} = V_{CC}$, $V_{in} = GND$ to V_{CC} , $T_A = 25^\circ C$. This parameter is guaranteed but not tested.

Table 1. Non-Contending Read/Write Control

Control				I/O		Operation
R/W _{LB}	R/W _{UB}	CE	OE	I/O ₀ -I/O ₈	I/O ₉ -I/O ₁₇	
X	X	H	X	High Z	High Z	Deselected: Power-Down
L	L	L	X	Data In	Data In	Write to Both Bytes
L	H	L	L	Data In	Data Out	Write Lower Byte, Read Upper Byte
H	L	L	L	Data Out	Data In	Read Lower Byte, Write Upper Byte
L	H	L	H	Data In	High Z	Write to Lower Byte
H	L	L	H	High Z	Data In	Write to Upper Byte
H	H	L	L	Data Out	Data Out	Read to Both Bytes
H	H	L	H	High Z	High Z	High Impedance Outputs

Table 2. Address BUSY Arbitration

Inputs			Outputs		Function
CE _L	CE _R	Address _L Address _R	BUSY _L	BUSY _R	
X	X	No Match	H	H	Normal
H	X	Match	H	H	Normal
X	H	Match	H	H	Normal
L	L	Match	Note 27	Note 27	Write Inhibit ^[28]

Notes:

27. The loser of the port arbitration will receive BUSY = "L" (BUSY_L or BUSY_R = "L"). BUSY_L and BUSY_R cannot both be LOW simultaneously.
 28. Writes are inhibited to the left port when BUSY_L is LOW. Writes are inhibited to the right port when BUSY_R is LOW.

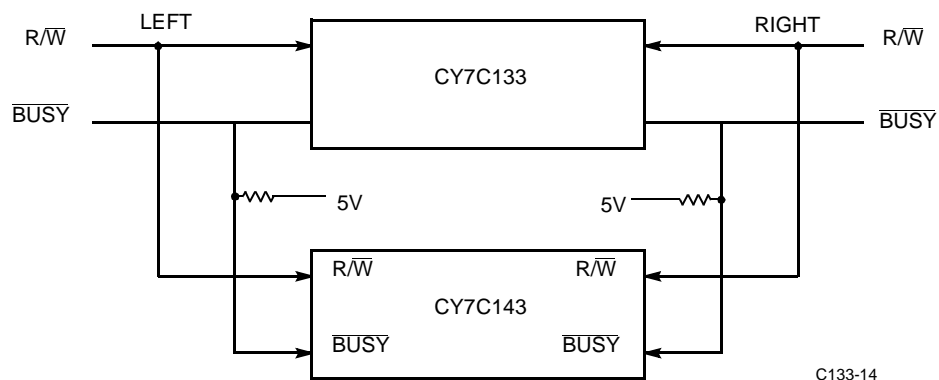
32-Bit Master/Slave Dual-Port Memory Systems

C133-14

Table 3. Arbitration Results

Case	Port		Winning Port	Result
	Left	Right		
1	Read	Read	L	Both ports read
2	Read	Read	R	Both ports read
3	Read	Write	L	L port reads OK R port write inhibited
4	Read	Write	R	R port writes OK L port data may be invalid
5	Write	Read	L	L port writes OK R port data may be invalid
6	Write	Read	R	R port reads OK L port write inhibited
7	Write	Write	L	L port writes OK R port write inhibited
8	Write	Write	R	R port writes OK L port write inhibited

Ordering Information
2K x16 Master Dual-Port SRAM

Speed (ns)	Ordering Code	Package Name	Package Type	Operating Range
25	CY7C133-25JC	J81	68-Lead Plastic Leaded Chip Carrier	Commercial
	CY7C133-25JI	J81	68-Lead Plastic Leaded Chip Carrier	Industrial
35	CY7C133-35JC	J81	68-Lead Plastic Leaded Chip Carrier	Commercial
	CY7C133-35JI	J81	68-Lead Plastic Leaded Chip Carrier	Industrial
55	CY7C133-55JC	J81	68-Lead Plastic Leaded Chip Carrier	Commercial
	CY7C133-55JI	J81	68-Lead Plastic Leaded Chip Carrier	Industrial

2K x16 Slave Dual-Port SRAM

Speed (ns)	Ordering Code	Package Name	Package Type	Operating Range
25	CY7C143-25JC	J81	68-Lead Plastic Leaded Chip Carrier	Commercial
	CY7C143-25JI	J81	68-Lead Plastic Leaded Chip Carrier	Industrial
35	CY7C143-35JC	J81	68-Lead Plastic Leaded Chip Carrier	Commercial
	CY7C143-35JI	J81	68-Lead Plastic Leaded Chip Carrier	Industrial
55	CY7C143-55JC	J81	68-Lead Plastic Leaded Chip Carrier	Commercial
	CY7C143-55JI	J81	68-Lead Plastic Leaded Chip Carrier	Industrial

Document #: 38-00414-B

Package Diagram

68-Lead Plastic Leaded Chip Carrier J81

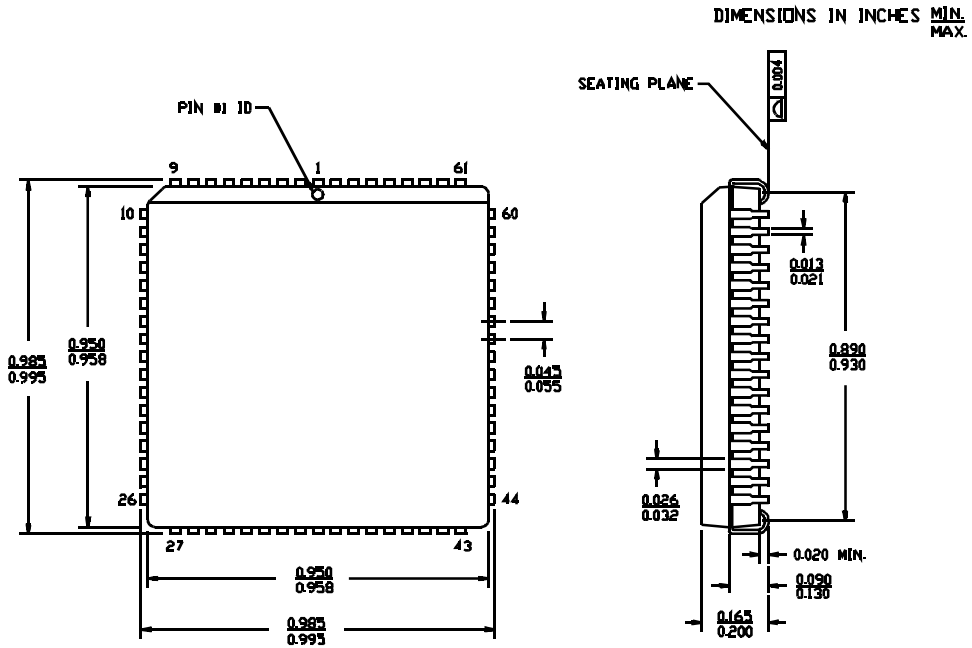

51-85005-A