

Motor driver for CD-ROMs

BA6665FM

The BA6665FM is a CD-ROM spindle motor driver supporting reverse-rotation preventing circuit. It incorporates power save circuit, thermal shut down circuit, FG output, hall bias, etc. The 3-phasefull-wave pseudo linear driving system achieves high-performance and multi-function.

●Applications

CD-ROM / RW, DVD-ROM

●Features

- 1) 3-phase, full-wave pseudo linear driving system
- 2) Built in power save
- 3) Built in thermal shut down circuit
- 4) Built in current limit circuit
- 5) Built in Hall Bias circuit
- 6) Built in FG-output (3 phase parallel output)
- 7) With switching function of regular / reverse rotations

●Absolute maximum ratings (Ta=25°C)

Parameter	Symbol	Limits	Unit
Supply voltage	V _{CC}	7	V
Supply voltage	V _M	15	V
Power dissipation	P _d	2200*1	mW
Operate.temp.range	T _{opr}	-20~+75	°C
Strage.temp.range	T _{stg}	-55~+150	°C
Junction temp.	T _{jmax}	150	°C
Maximum o.current	I _{OUT}	1300*2	mA

70mm×70mm×1.6mm glass epoxy board.

*1 Derating in done at 17.6mW / °C for operating above Ta=25°C.

*2 Do not, however exceed Pd, ASO and T_j=150°C.

●Recommended operating conditions (Ta=25°C)

Parameter	Symbol	Min.	Typ.	Max.	Unit
Operating supply voltage range	V _{CC}	4.5	–	5.5	V
	V _M	3.0	–	14.0	

Optical disc ICs

●Block diagram

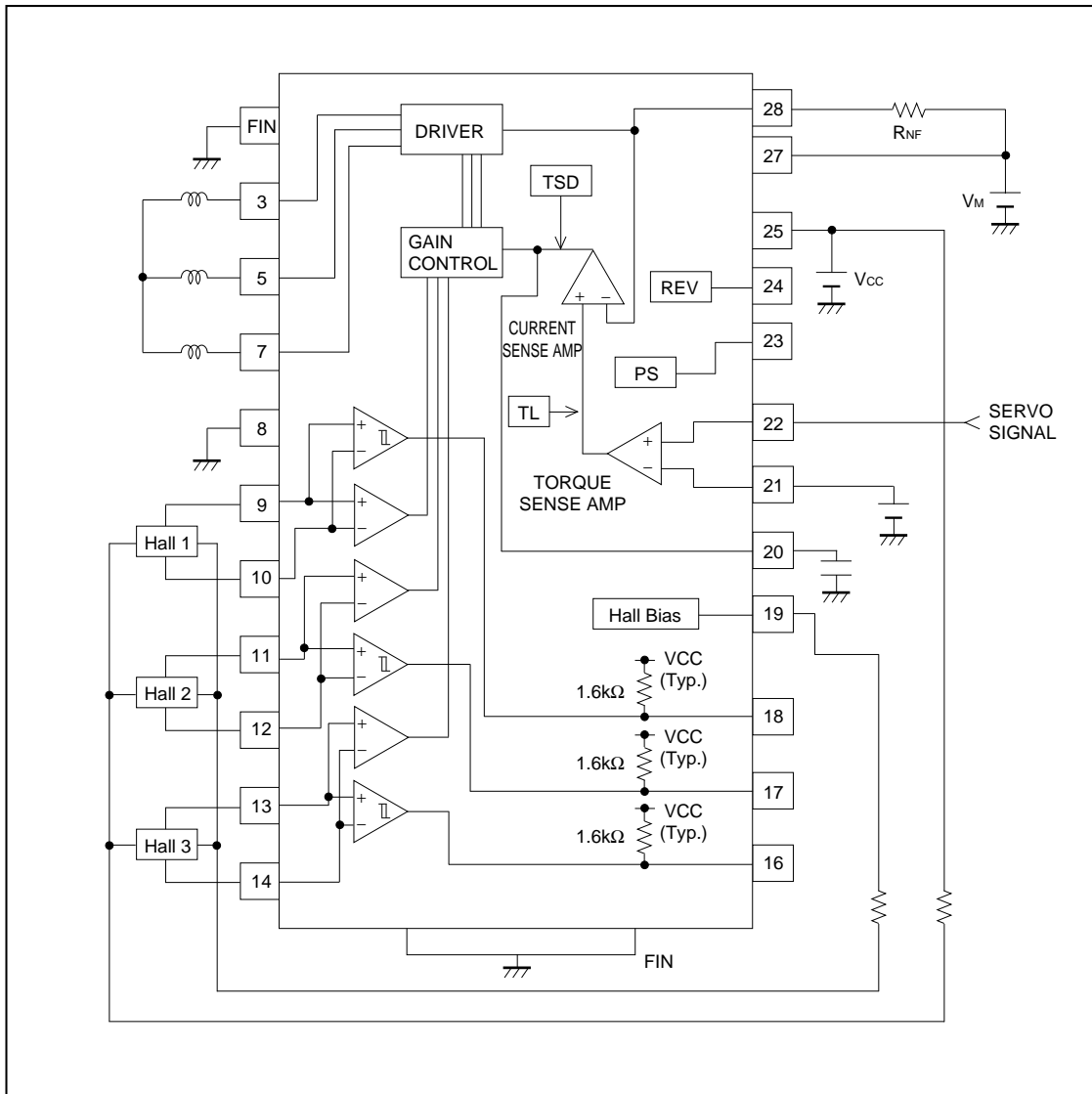

Optical disc ICs

●Pin descriptions

Pin No.	Pin Name	Function
1	N.C.	N.C.
2	N.C.	N.C.
3	A ₃	Output3 for motor
4	N.C.	N.C.
5	A ₂	Output2 for motor
6	N.C.	N.C.
7	A ₁	Output1 for motor
8	GND	GND
9	H ₁ ⁺	Hall input Amp1. positive input
10	H ₁ ⁻	Hall input Amp1. negative input
11	H ₂ ⁺	Hall input Amp2. positive input
12	H ₂ ⁻	Hall input Amp2. negative input
13	H ₃ ⁺	Hall input Amp3. positive input
14	H ₃ ⁻	Hall input Amp3. negative input
15	N.C.	N.C.
16	FG3	FG3 signal output terminal
17	FG2	FG2 signal output terminal
18	FG1	FG1 signal output terminal
19	V _H	Hall bias
20	C _{NF}	Capacitor connection pin for phase compensation
21	E _{CR}	Torque control standard voltage input terminal
22	E _C	Torque control voltage input terminal
23	PS	START / STOP switch
24	R _{EV}	Reverse terminal
25	V _{CC}	Power supply for signal division
26	N.C.	N.C.
27	V _M	Power supply for driver
28	R _{NF}	Terminal connection for current sensing resistor
FIN	FIN	GND

Optical disc ICs

●Electrical characteristics (unless otherwise noted, Ta=25°C, Vcc=5V, VM=12V)

Parameter	Symbol	Min.	Typ.	Max.	Unit	Conditions	Test Circuit
〈TOTAL〉							
Circuit current1	Icc1	–	0	0.2	mA	At power save ON	Fig.1
Circuit current2	Icc2	–	4.7	7.1	mA	At power save OFF	Fig.1
〈POWER SAVE〉							
ON voltage range	V _{PSON}	2.5	–	–	V		Fig.2
OFF voltage range	V _{PSOFF}	–	–	1.0	V		Fig.2
〈HALL BIAS〉							
Hall bias voltage	V _{HB}	0.5	0.9	1.5	V	I _{HB} =10mA	
〈HALL AMP〉							
Input bias current	I _{HA}	–	0.7	3.0	μA		Fig.3
In-phase input voltage range	V _{HAR}	1.5	–	4.0	V		Fig.3
Minimum input level	V _{INH}	50	–	–	mVpp		Fig.3
H ₃ hysteresis level	V _{HYS}	10	20	40	mV		Fig.6
〈TORQUE CONTROL〉							
Input voltage range	E _c , E _{CR}	0	–	5	V	E _c , E _{CR} =0.5V~3.3V	
Offset voltage –	E _{COFF –}	–70	–40	–10	mV	E _{CR} =1.65V	Fig.5
Offset voltage +	E _{COFF +}	10	40	70	mV	E _{CR} =1.65V	Fig.5
Input current	E _{CIN}	–	0.5	2.0	μA	E _c =E _{CR} =1.65V	
Input-output Gain	G _{EC}	0.56	0.7	0.84	A / V	E _c =1.3, 1.5V 1.8, 2.0V R _{NF} =0.5Ω	Fig.5
〈FG〉							
FG output voltage H	V _{FGH}	4.5	4.9	5.0	V	I _{FG} =–20μA	Fig.6
FG output voltage L	V _{FGL}	0	0.25	0.4	V	I _{FG} =3mA	Fig.6
〈OUTPUT〉							
Saturation voltage H	V _{OH}	–	1.0	1.5	V	I _o =–600mA	Fig.4
Saturation voltage L	V _{OL}	–	0.4	0.8	V	I _o =600mA	Fig.4
Pre-drive current	I _{VMP}	–	35	70	mA	E _c =5V output open	Fig.6
Torque limit current	I _{TL}	560	700	840	mA	R _{NF} =0.5Ω	Fig.2
〈REVERSE〉							
ON voltage range	V _{RSON}	2.5	–	–	V		
OFF voltage range	V _{RSOFF}	–	–	1.0	V		

Optical disc ICs

● Measurement circuit

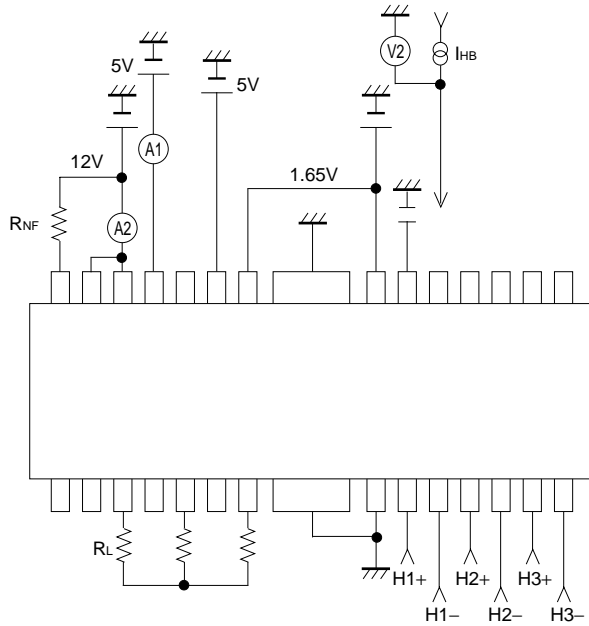

ICC1 : Value of 'A1'
 VPS=0 [V]
 $H1+ \sim H3+ = (1/2) \times VCC + 0.1$ [V]
 $H1- \sim H3- = (1/2) \times VCC$ [V]

ICC2 : Value of 'A2'
 VPS=5 [V]
 $H1+ \sim H3+ = (1/2) \times VCC + 0.1$ [V]
 $H1- \sim H3- = (1/2) \times VCC$ [V]

VHB : Value of 'V2'
 VPS=5 [V]
 IHB=10 [mA]

Fig.1 Circuit current Hall bias voltage) Test Circuit

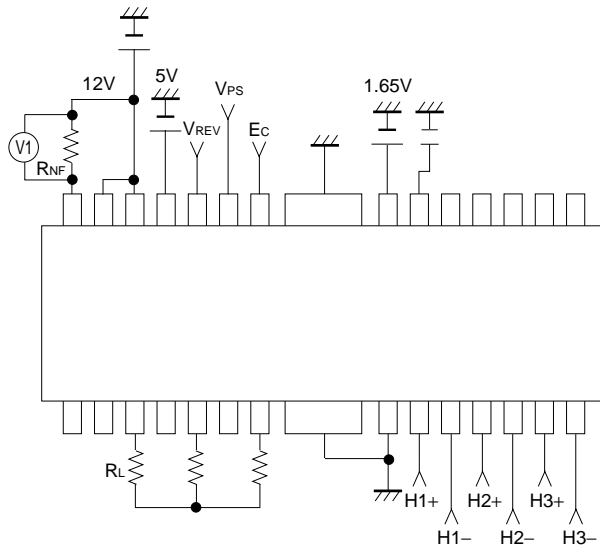

VPSON : Range of 'VPS' that output pins become input-output table. (Input condition 1-6)

VPSONOFF : Range of 'VPS' that output pins become open. (Input condition 1-6)

VRSON : Range of 'VREV' that output pins become input-output table. (Input condition 1-6)
 VPS=5 [V] EC=0 [V]

VRSONOFF : Range of 'VREV' that output pins become open. (Input condition 1-6)
 VPS=5 [V] EC=0 [V]

ITL : (Value of 'V1') / 0.5
 VPS=5 [V] EC=0 [V]
 (Input condition 1-6)

PS ON/OFF range REV ON/OFF range) Test Circuit
 Torque limit current

Optical disc ICs

Input-output table

Pin No.	Input conditions						Output						Test point (Regular)
							Regular			Reverse			
	9	10	11	12	13	14	7	5	3	7	5	3	
	H1+	H1-	H2+	H2-	H3+	H3-	A1	A2	A3	A1	A2	A3	
Condition 1	L	M	H	M	M	M	H	L	L	L	H	H	7pin HI
Condition 2	H	M	L	M	M	M	L	H	H	H	L	L	7pin Low
Condition 3	M	M	L	M	H	M	L	H	L	H	L	H	5pin HI
Condition 4	M	M	H	M	L	M	H	L	H	L	H	L	5pin Low
Condition 5	H	M	M	M	L	M	L	L	H	H	H	L	3pin HI
Condition 6	L	M	M	M	H	M	H	H	L	L	L	H	3pin Low

Cautions 1 : Regular EC<ECR REV = L, EC>ECR REV=H

Reverse EC<ECR REV = L,

Input voltage : Hi = 2.6V

Mid = 2.5V

Low = 2.4V

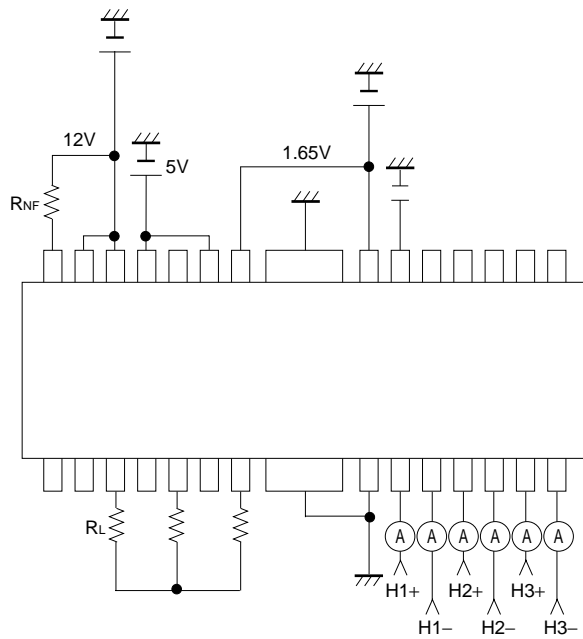

IHA : Value of 'A1' ($Hn^+=4.0V, Hn^-=2.5V$)
 Value of 'A2' ($Hn^+=2.5V, Hn^-=4.0V$)
 $n=1, 2, 3$

VHAR : Hall voltage range that output pins become input-output table.

VINH : Hall input level that output pins become input-output table.
 $|Hn^+ - Hn^-| \quad Hn^-=2.5V \quad (n=1, 2, 3)$

Fig.3 Input bias current
 In-phase input voltage range
 Hall minimum input level) Test Circuit

Optical disc ICs

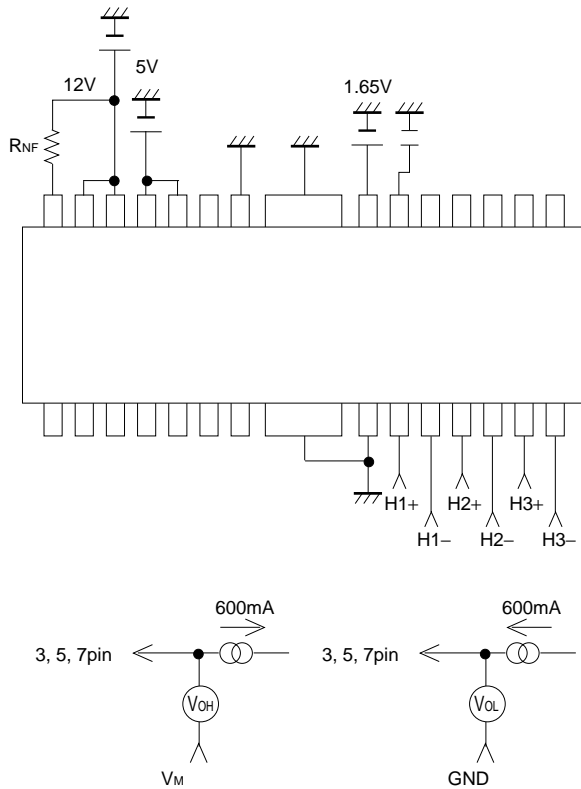

VOH : In case output measurement pin='H'
by input condition and IO=-600mA,
value of 'VOH'. (VM-RNF short)

VOL : In case output measurement pin='L'
by input condition and IO=600mA,
value of 'VOL'.

Fig.4 Output saturation voltage H) Test Circuit
Output saturation voltage L)

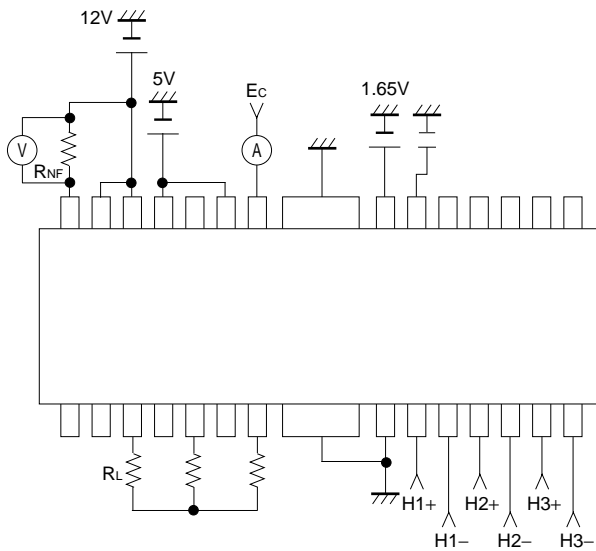

EC : Torque control operating. range.

ECOFF+, ECOFF- : Offset voltage at ECR=1.65V that
value of 'V' become 3mV.

ECIN : Value of 'A' at EC=ECR=2.5V

GEC : Value of 'V' at EC=1.3V→V1
Value of 'V' at EC=1.5V→V2
Value of 'V' at EC=1.8V→V3
Value of 'V' at EC=2.0V→V4

$GEC = \frac{(V1 - V2)}{(1.5 - 1.3)} / RNF$
 $GEC = \frac{(V4 - V3)}{(2.0 - 1.8)} / RNF$
RNF=0.5Ω

Fig.5 Torque offset voltage) Test Circuit
Input-output gain)

Optical disc ICs

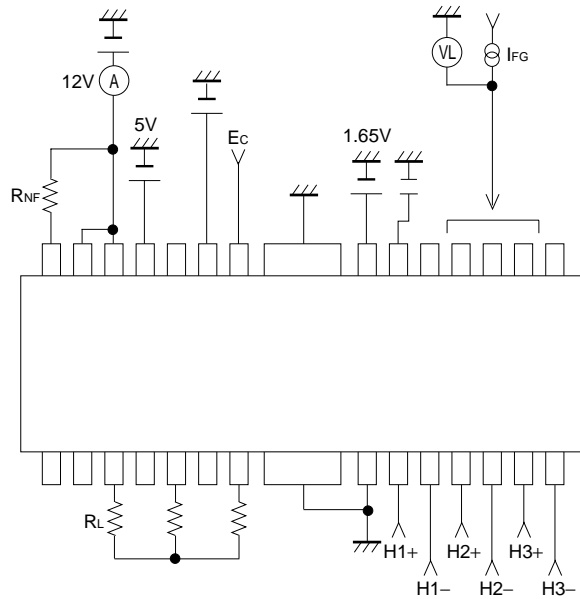

VHYS : Difference H_n^+ from H_n^- that
 FG1 / FG2 / FG3 voltage change. (n=1, 2, 3)
 EC=ECR=1.65V

IVMp : value of 'A'
 Output open
 (Input condition 1-6)
 EC=5V, ECR=2.5V

VFGL : Value of 'FG-OUTPUT-VOLTAGE'
 at IFG=3mA ($H_n^+=L$)

VFGH : Value of 'FG-OUTPUT-VOLTAGE'
 at IFG=-20 μ A ($H_n^+=H$)

Fig.6 Hall hysteresis level
 Pre-drive current
 FG output voltage H
 FG output voltage L) Test Circuit

●Electrical characteristic curves

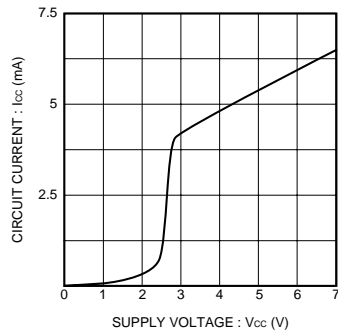

Fig.7 Circuit Current

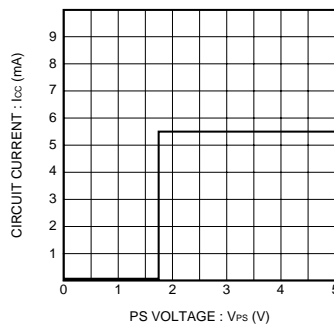

Fig.8 PS Threshold voltage

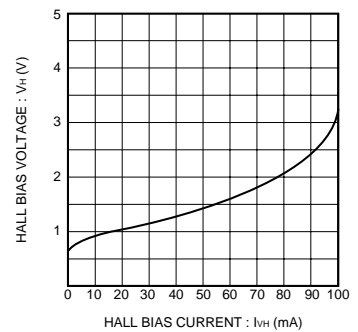

Fig.9 Hall Bias voltage

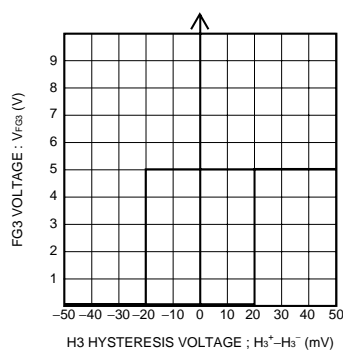

Fig.10 H3 Hysteresis Level

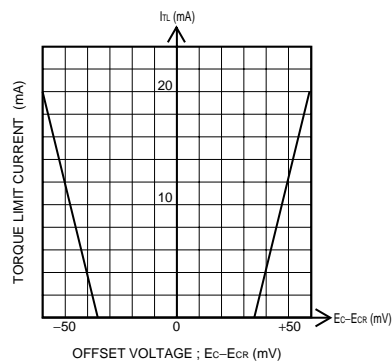

Fig.11 Torque Control Offset voltage

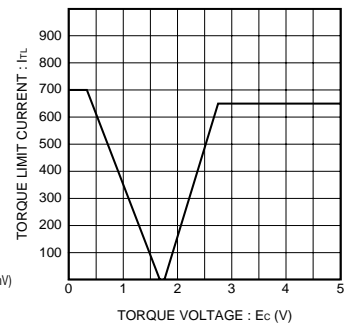

Fig.12 Torque Limit Current

Optical disc ICs

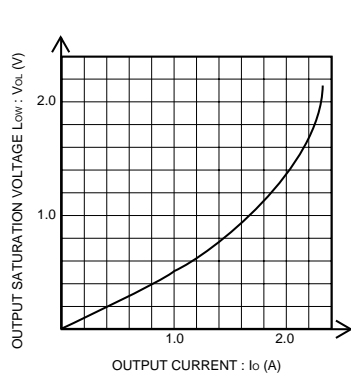

Fig.14 Output Saturation voltage Low

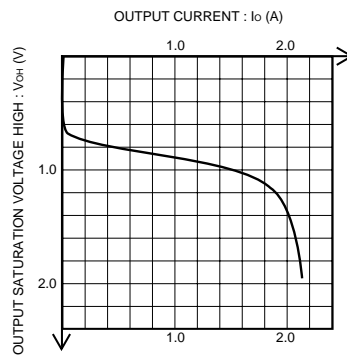

Fig.13 Output Saturation voltage HI

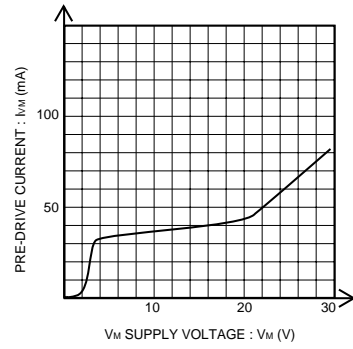

Fig.15 Pre-drive Current

●External dimensions (Units : mm)

