

Features

- Passive Line Termination (PLT) for MT8910 DSLIC
- High precision trimmed resistors
- Excellent resistor matching required to meet longitudinal balance as specified in ANSI-T1.601
- Compact SIL package

Applications

- Pair gain system
- ISDN NT1 and NT2 interfaces
- Digital multiplexers and concentrators
- ISDN U-interface terminals

ISSUE 1

August 1991

Ordering Information

MH89101 6 Pin SIL Package

0°C to +70°C
Description

The MH89101 is a thick film hybrid device which is used in conjunction with the MT8910 to perform two to four wire conversion and analog signal conditioning on the received 2B1Q signal.

The signal conditioning is necessary to enable the DSLIC to interface to the Digital Subscriber Line as defined in ANSI T1.601-1988. The precanceller block will perform two to four wire conversion and provide adequate isolation between transmit and receive paths.

The small size and the precise resistor matching on the hybrid makes it suitable for line card or terminals which use the MT8910 2B1Q U-Interface Transceiver.

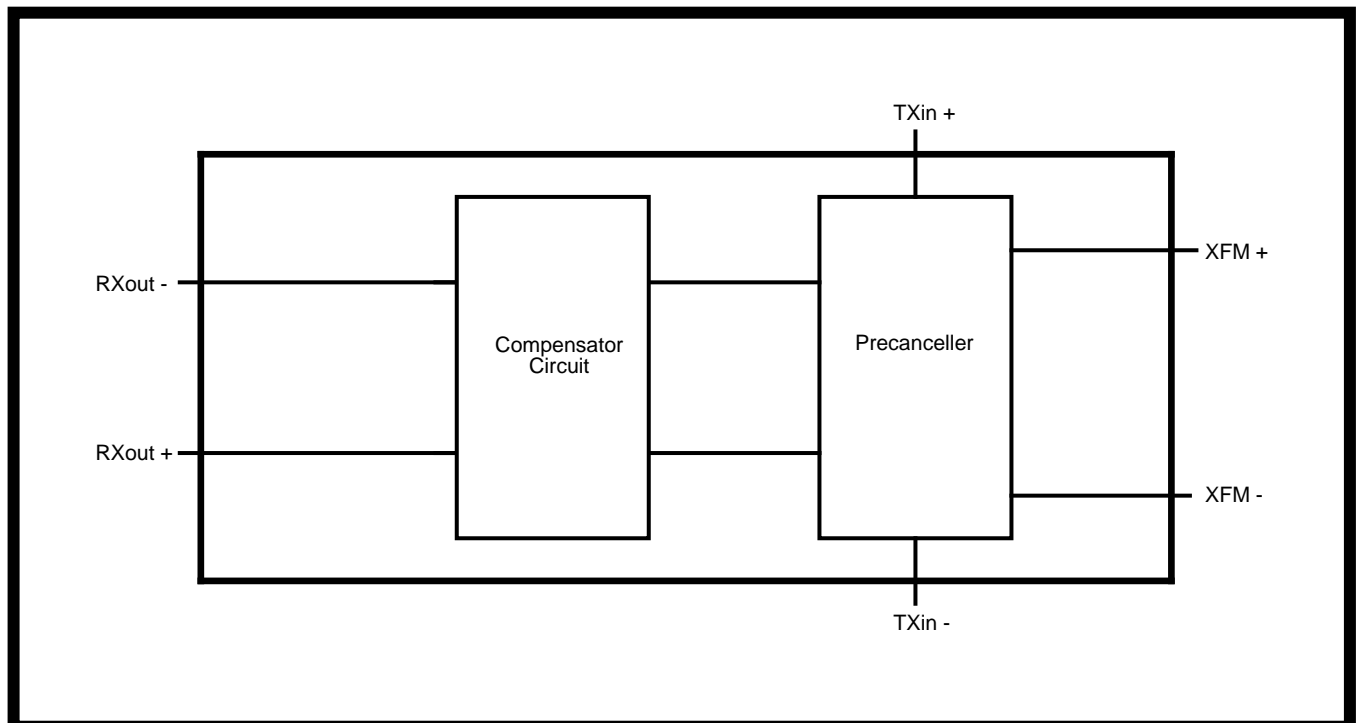
Figure 1 - Functional Block Diagram

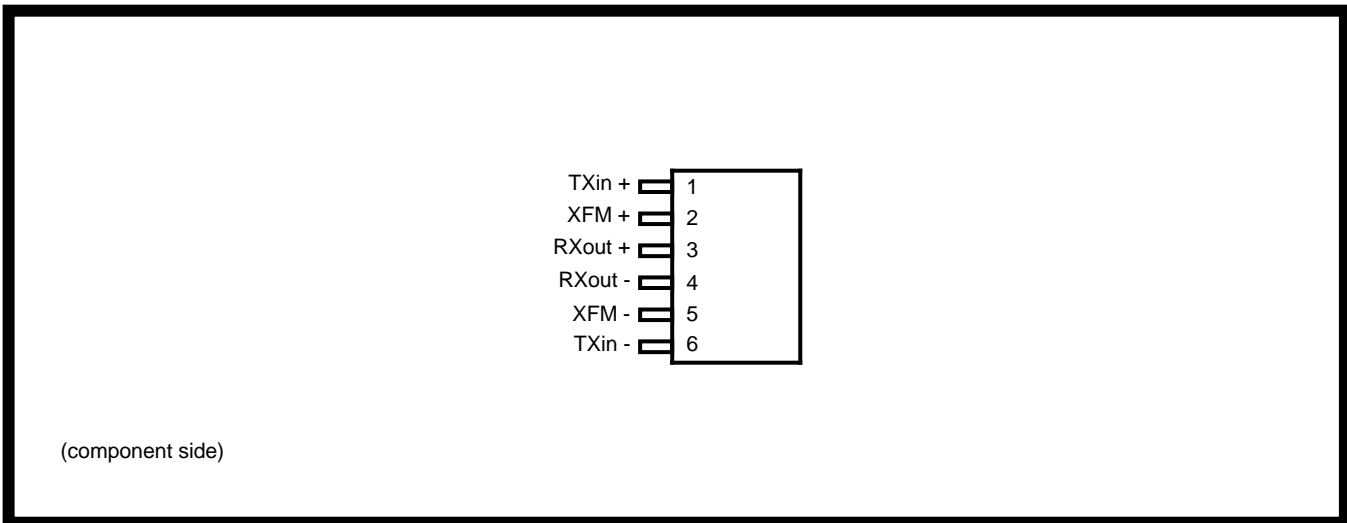

Figure 2 - Pin Connections

Pin Description

Pin #	Name	Description
1	TX _{in+}	Transmit Line Signal Input. Must be connected to the L _{out+} output of the DSLIC.
2	XFM+	Transformer. Node of the 2 to 4 wire converter which must be connected to the primary of the line transformer.
3	RX _{out+}	Receive Line Signal Output. Output of the compensator circuit which must be connected to the L _{in+} input of the DSLIC.
4	RX _{out-}	Receive Line Signal Output. Output of the compensator circuit which must be connected to the L _{in-} input of the DSLIC.
5	XFM-	Transformer. Node of the 2 to 4 wire converter which must be connected to the primary of the line transformer.
6	TX _{in-}	Transmit Line Signal Input. Must be connected to the L _{out-} output of the DSLIC.

Functional Description

The termination network is an all passive circuit which allows the DSLIC to interface to the DSL through a pulse transformer. The equivalent circuit of the Passive Line Termination Network can be seen in Figure 3 below.

The PLT consists of two blocks which includes a hybrid network and a compensator circuit.

The hybrid network is a 2 to 4 wire converter which provides a large degree of precancellation of the near end signal while presenting little attenuation to the far end signal. This is performed using a summing junction which effectively subtracts the transmit signal from the receive path.

The compensator circuit, in conjunction with the transformer, acts as a highpass filter reducing the low frequency content in the received line signal. This, in turn, decreases the effects of ISI and near end echo, and improves the transceiver performance.

Typical Application

Figure 4 shows a typical connection diagram of the MT8910 DSLIC and the Passive Line Termination Circuit. As seen in Figure 4, the PLT is positioned between the DSLIC and the line pulse transformer. Two series protection resistors on the secondary of the line pulse transformer are used to dissipate any extraneous energy which may be induced onto the transmission line.

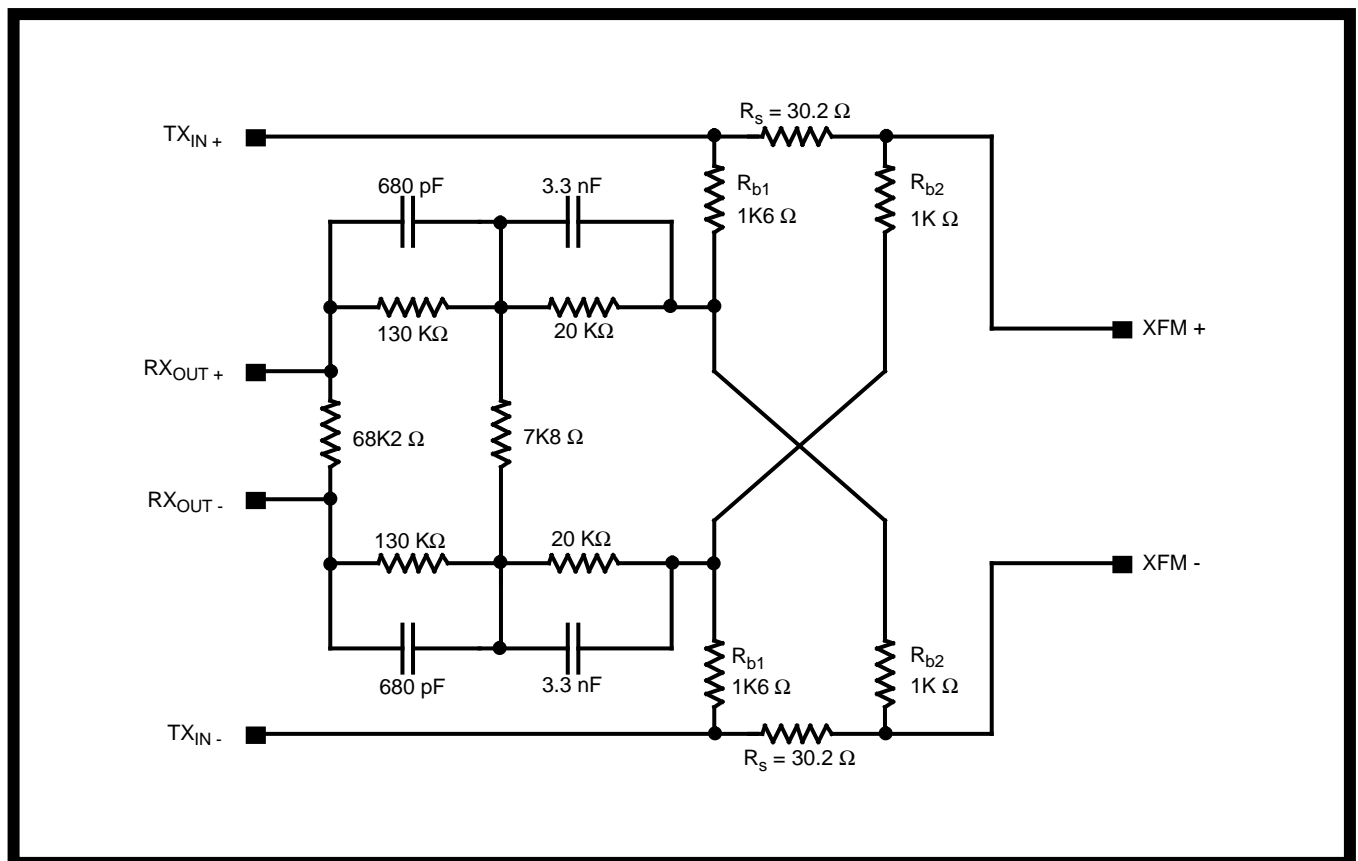

Figure 3 - Passive Line Termination Network

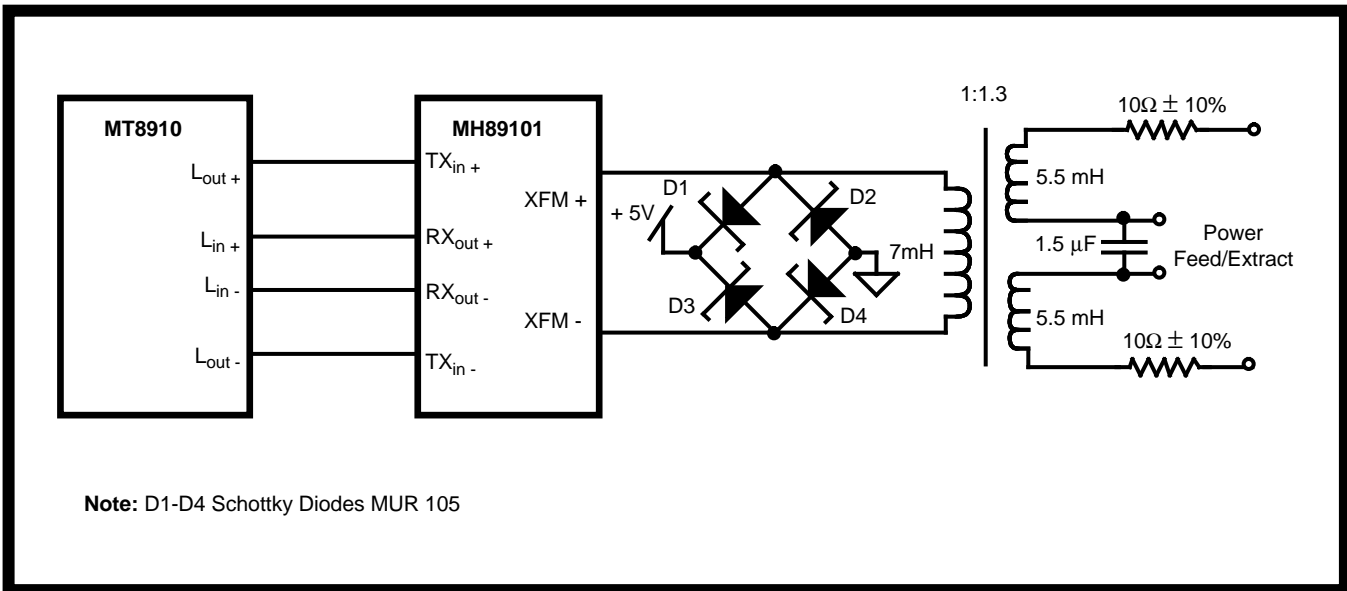

Figure 4 - Typical Connection Diagram

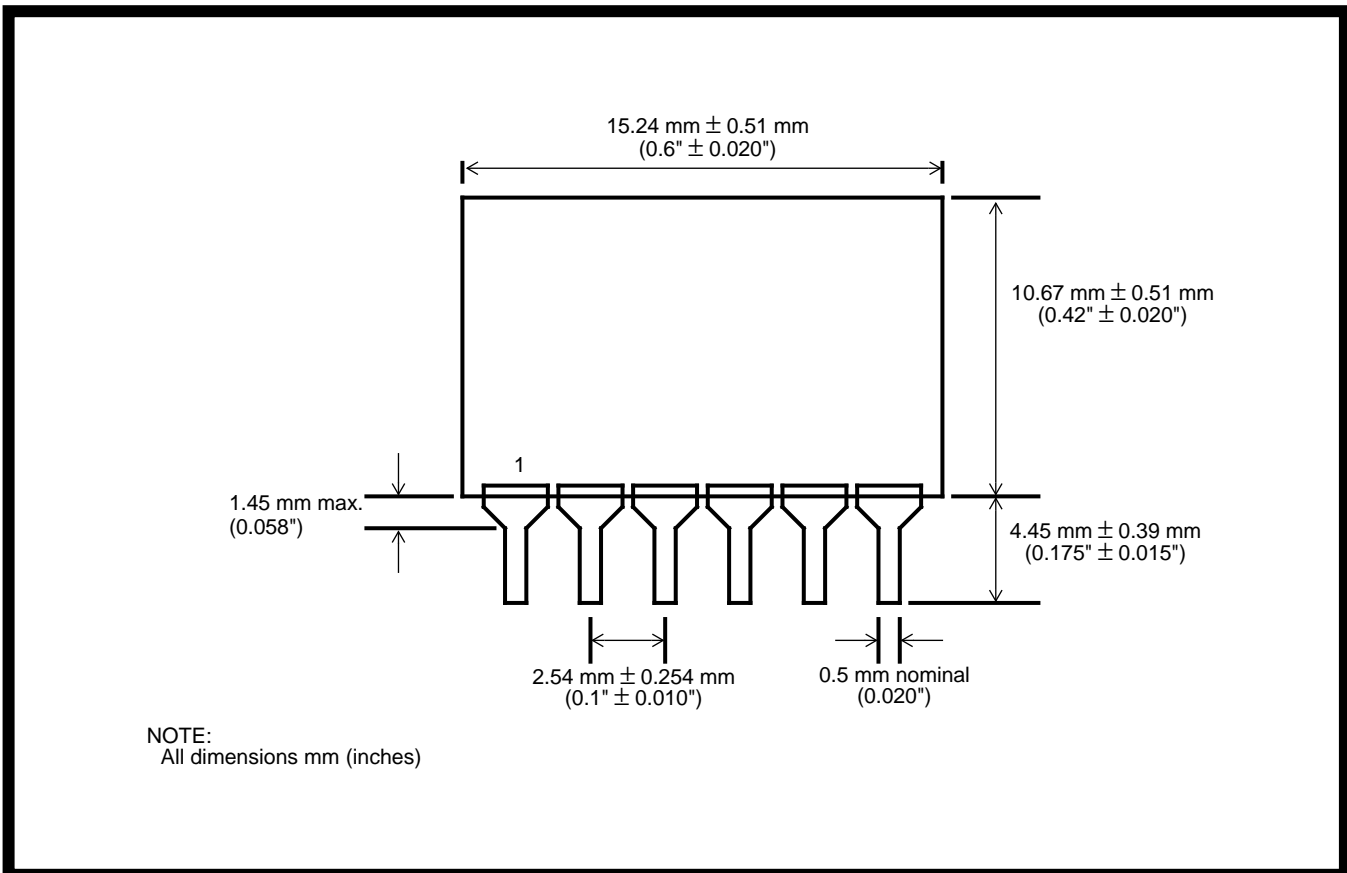

Figure 5 - Physical Dimensions



**For more information about all Zarlink products
visit our Web Site at
www.zarlink.com**

Information relating to products and services furnished herein by Zarlink Semiconductor Inc. trading as Zarlink Semiconductor or its subsidiaries (collectively "Zarlink") is believed to be reliable. However, Zarlink assumes no liability for errors that may appear in this publication, or for liability otherwise arising from the application or use of any such information, product or service or for any infringement of patents or other intellectual property rights owned by third parties which may result from such application or use. Neither the supply of such information or purchase of product or service conveys any license, either express or implied, under patents or other intellectual property rights owned by Zarlink or licensed from third parties by Zarlink, whatsoever. Purchasers of products are also hereby notified that the use of product in certain ways or in combination with Zarlink, or non-Zarlink furnished goods or services may infringe patents or other intellectual property rights owned by Zarlink.

This publication is issued to provide information only and (unless agreed by Zarlink in writing) may not be used, applied or reproduced for any purpose nor form part of any order or contract nor to be regarded as a representation relating to the products or services concerned. The products, their specifications, services and other information appearing in this publication are subject to change by Zarlink without notice. No warranty or guarantee express or implied is made regarding the capability, performance or suitability of any product or service. Information concerning possible methods of use is provided as a guide only and does not constitute any guarantee that such methods of use will be satisfactory in a specific piece of equipment. It is the user's responsibility to fully determine the performance and suitability of any equipment using such information and to ensure that any publication or data used is up to date and has not been superseded. Manufacturing does not necessarily include testing of all functions or parameters. These products are not suitable for use in any medical products whose failure to perform may result in significant injury or death to the user. All products and materials are sold and services provided subject to Zarlink's conditions of sale which are available on request.

Purchase of Zarlink's I²C components conveys a licence under the Philips I²C Patent rights to use these components in an I²C System, provided that the system conforms to the I²C Standard Specification as defined by Philips.

Zarlink and the Zarlink Semiconductor logo are trademarks of Zarlink Semiconductor Inc.

Copyright 2002, Zarlink Semiconductor Inc. All Rights Reserved.

TECHNICAL DOCUMENTATION - NOT FOR RESALE
