

SUBMINIATURE, HIGH SENSITIVITY PHOTOINTERRUPTER

*Features

- Compact and thin.
- Visible light cut-off type.
- High sensitivity.
- RoHS Compliant.

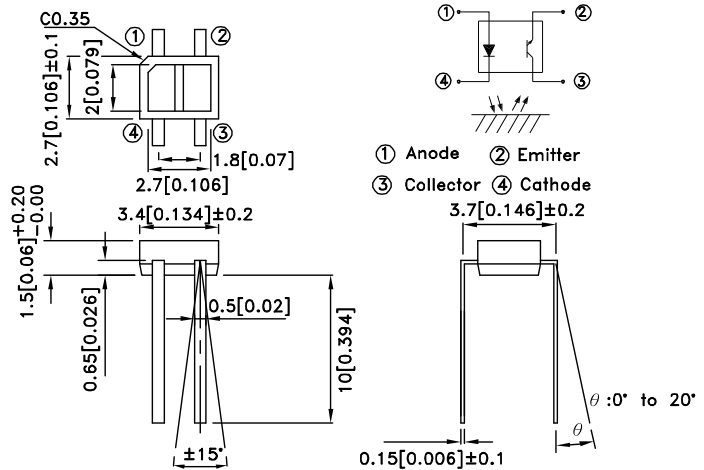

*Applications

- Cassette tape recorders, VCRs.
- Floppy disk drives.
- Various microcomputerized control equipment.

UNIT : MM[INCH]

TOLERANCE : ±0.25[± 0.01] UNLESS OTHERWISE NOTED.

*Absolute Maximum Ratings $T_a=25^\circ\text{C}$

Parameter		Symbol	Rating	Unit
Input	Forward current	I_F	50	mA
	Reverse voltage	V_R	6	V
	Power dissipation	P_D	75	mW
	Peak Forward Current (Pulse Width $\leq 100\mu\text{s}$, Duty Cycle = 1%)	I_{FP}	1	A
Output	Collector-emitter voltage	V_{CEO}	35	V
	Emitter-collector voltage	V_{ECO}	6	V
	Collector current	I_C	20	mA
	Collector power dissipation	P_C	75	mW
Operating temperature		T_{opr}	-25~+85	$^\circ\text{C}$
Storage temperature		T_{stg}	-40~+100	$^\circ\text{C}$
soldering temperature (1/16 inch from body for 5 seconds)		T_{sol}	260	$^\circ\text{C}$



Electro-optical Characteristics

Parameter		Symbol	Conditions	Min.	TYP.	Max.	Unit	
Input	Forward Voltage	V_F	$I_F=20\text{mA}$	1.0	1.2	1.5	V	
	Reverse Current	I_R	$V_R=6\text{V}$	-	-	10	μA	
	Peak Wavelength	λ_P	$I_F=20\text{mA}$	-	940	-	nm	
Output	Collector Dark Current	I_{CEO}	$V_{CE}=20\text{V}$	-	10^{-9}	10^{-7}	A	
Transfer characteristics	*1 Collector Current	I_C	$V_{CE}=2\text{V}$ $I_F=4\text{mA}$	10	-	400	μA	
	*2 Leak Current	I_{LEAK}	$V_{CE}=2\text{V}$ $I_F=4\text{mA}$	-	-	0.1	μA	
	Response time	Rise time	t_r	$V_{CE}=2\text{V}$ $I_C=100\mu\text{A}$ $R_L=1\text{K}\Omega, d=1\text{mm}$	-	20	100	μsec
		Fall time	t_f		-	20	100	μsec

*1 The condition and arrangement of the reflective object are shown below.
 *2 Without reflective object.

BIN CODE	I_C (uA)
E	10-120
F	100-250
G	200-400

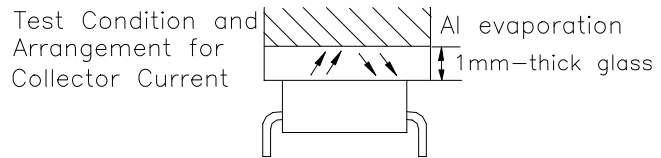

Fig. 1 Forward Current vs. Forward Voltage

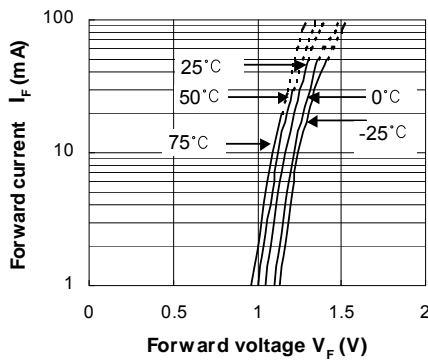

Fig. 3 Collector Current vs. Collector-emitter Voltage

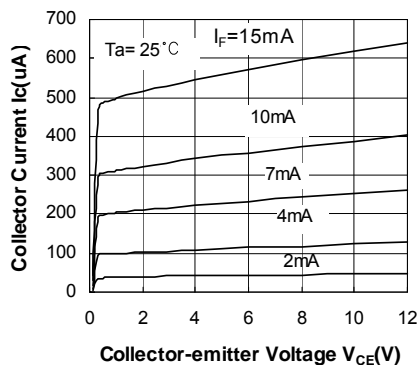

Fig. 2 Collector Current vs. Forward Current

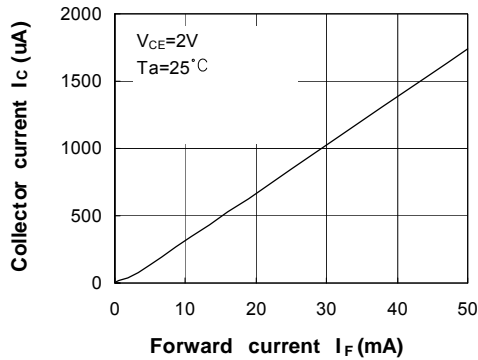

Fig. 4 Relative Collector Current vs. Ambient Temperature

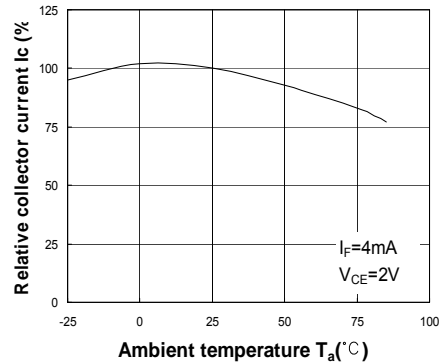
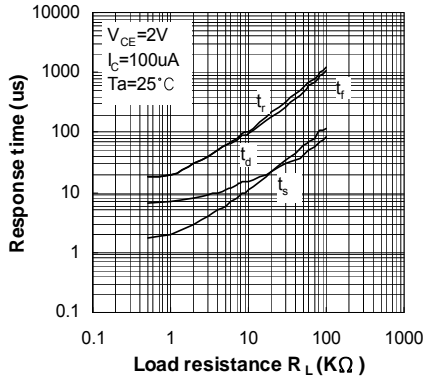

Fig. 5 Response Time vs. Load Resistance



Test Circuit for Response Time

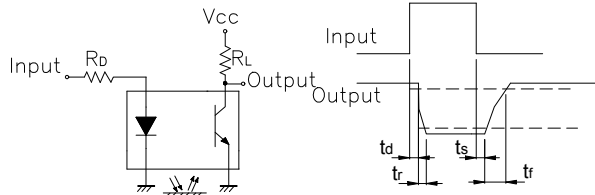

Fig. 6 Collector Dark Current vs. Ambient Temperature

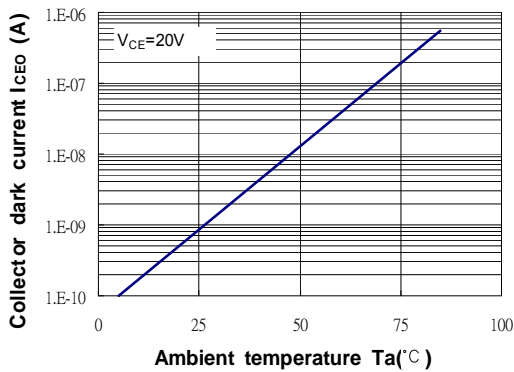

Fig. 7 Relative Collector Current vs. Distance between Sensor and Al Evaporation Glass

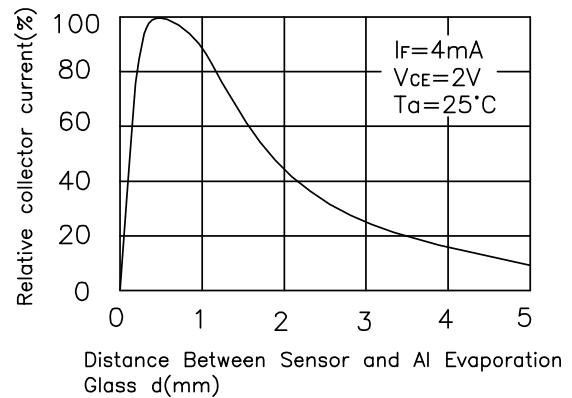

Fig. 8 Relative Collector Current vs. Card Moving Distance (1)

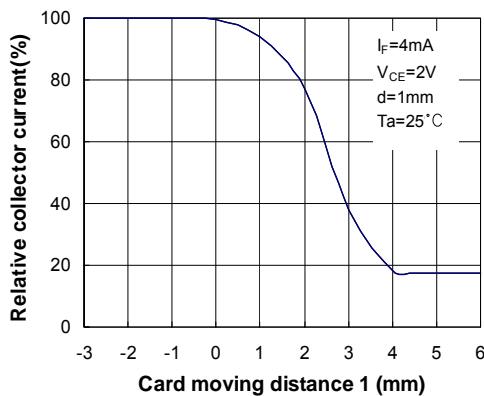
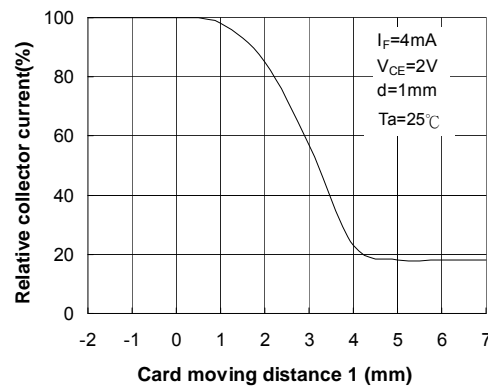
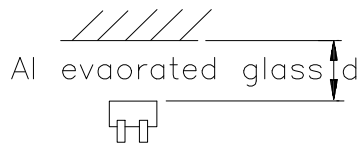

Fig. 9 Relative Collector Current vs. Card Moving Distance (2)



Test Condition for Distance&Detecting Position Characteristics

Correpond to Fig. 7



Correpond to Fig. 8
Test condition

$I_F = 4\text{mA}$
 $V_{CE} = 2\text{V}$
 $d = 1\text{mm}$

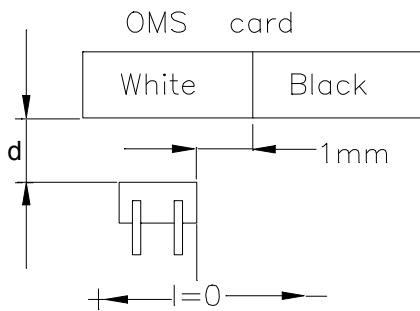

Correpond to Fig. 9
Test condition

$I_F = 4\text{mA}$
 $V_{CE} = 2\text{V}$
 $d = 1\text{mm}$

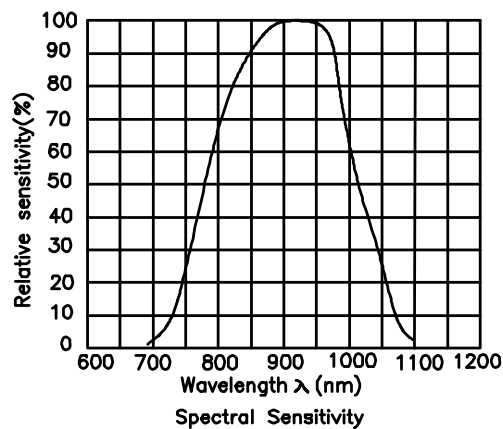
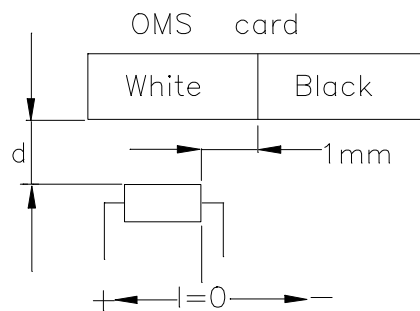

Wave Soldering Profile

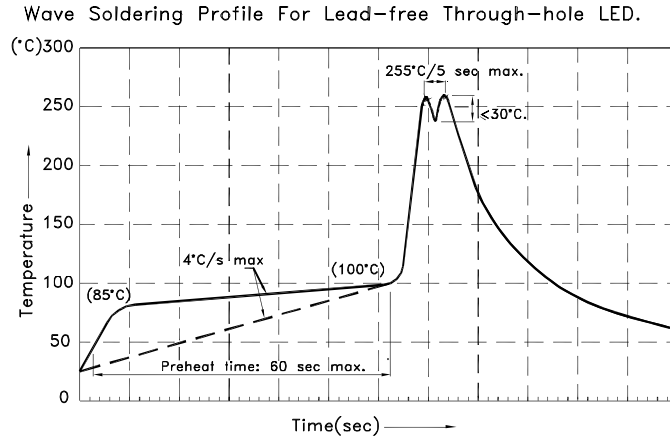

Notes:

1. Recommend pre-heat temperature of 105°C or less (as measured with a thermocouple attached to the LED pins) prior to immersion in the solder wave with a maximum solder bath temperature of 260°C
2. Peak wave soldering temperature between 245°C ~ 255°C for 3 sec (5 sec max).
3. Do not apply stress to the epoxy resin while the temperature is above 85°C.
4. Fixtures should not incur stress on the component when mounting and during soldering process.
5. SAC 305 solder alloy is recommended.
6. No more than one wave soldering pass.

PACKING & LABEL SPECIFICATIONS

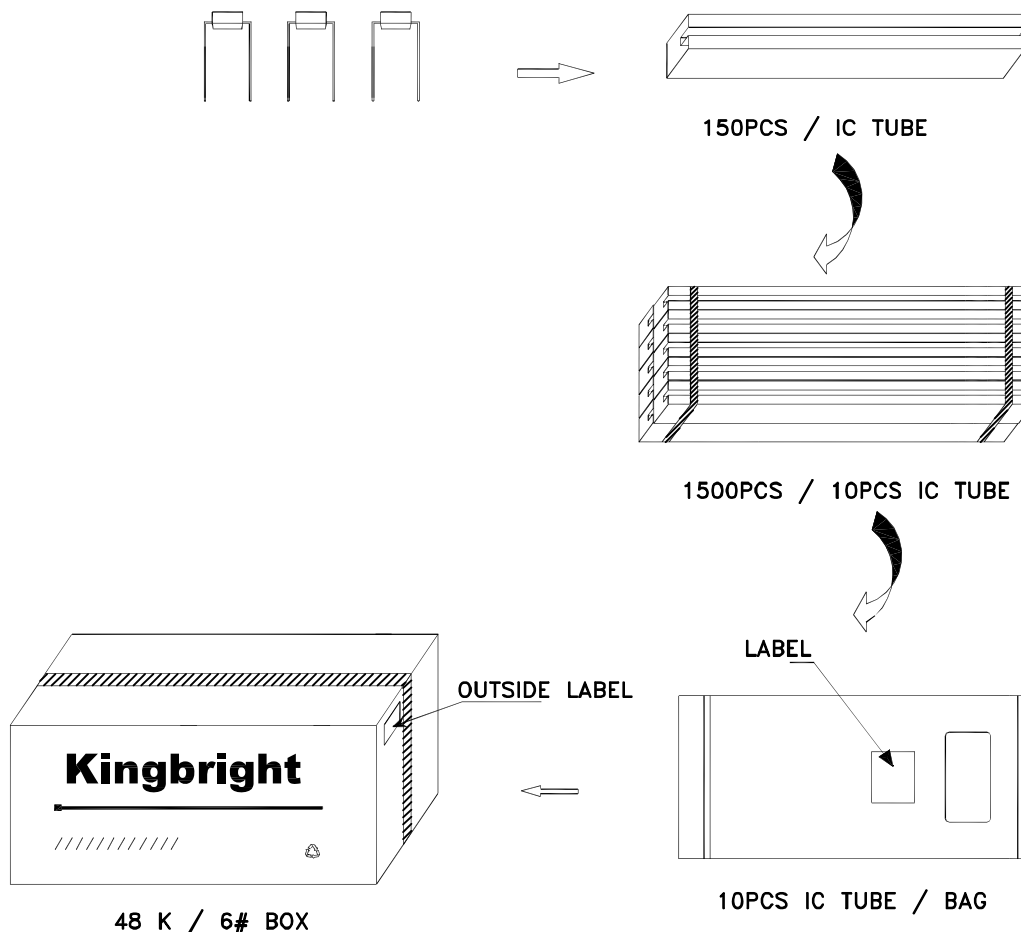

<h1>Kingbright</h1>					
P/NO: KTIRxxx					
QTY: 1500 pcs	Q.C.	<table border="1"> <tr> <td style="text-align: center;">Q C</td> </tr> <tr> <td style="text-align: center;">XX XX XXXX</td> </tr> <tr> <td style="text-align: center;">PASSED</td> </tr> </table>	Q C	XX XX XXXX	PASSED
Q C					
XX XX XXXX					
PASSED					
S/N: XXXX					
CODE: XXX					
LOT NO:					
					
XXXXXXXXXXXXXXXXXX					
RoHS Compliant					

Detailed application notes are listed on our website.

http://www.kingbright.com/application_notes