



Features

- RoHS compliant*
- Convex and concave terminals
- 2, 4 or 8 isolated elements available
- Resistance tolerance $\pm 1\%$ and $\pm 5\%$
- Resistance range: 10 ohms to 1 megohm

CAT/CAY 16 Series - Chip Resistor Arrays

Specifications

Requirement	Characteristics	Test Method
Short Time Overload	$\pm 2\% + 0.1$ ohm	Rated Voltage X 2.5, 5 seconds
Soldering Heat	$\pm 2\% + 0.1$ ohm	260 °C ± 5 °C, 10 seconds ± 1 second
Temperature Cycling (5)	$\pm 1\% + 0.1$ ohm	125 °C (30 minutes) - normal (15 minutes) -55 °C (30 minutes) - normal (15 minutes)
Moisture Load Life	$\pm 3\% + 0.1$ ohm	1000 hours
Load Life	$\pm 3\% + 0.1$ ohm	1000 hours

Characteristics

Characteristics	CAT16/CAY16
Number of Elements	2 (J2), 4 (F4, J4), 8 (F8, J8)
Power Rating Per Resistor @ 70 °C	0.0625 W
Package Power Rating @ 70 °C	0.250 W (0.125 W for J2)
Temperature Coefficient of Resistance	± 200 PPM/°C
Resistance Tolerance	$\pm 1\%$, $\pm 5\%$
Resistance Range: E24 (J), E96 + E24 (F) Zero-Ohm Jumper < 0.05 ohm	10 ohms - 1 megohm
Max. Working Voltage	50 V (25 V for CAY16-J8)
Operating Temp. Range	-55 °C - 125 °C

How To Order

CA Y 16 - 103 J 4 LF

Chip Arrays

Type

- CAT16 = Concave Terminations
- CAY16 = Convex Terminations

Resistance Code

- For 1 % Tolerance:
 - <100 ohms - "R" represents decimal point (example: 24R3 = 24.3 ohms)
 - ≥ 100 ohms - First three digits are significant, fourth digit represents number of zeros to follow (example: 8252 = 82.5k ohms)
- For 5 % Tolerance:
 - <10 ohms - "R" represents decimal point (example: 4R7 = 4.7 ohms)
 - ≥ 10 ohms - First two digits are significant, third digit represents number of zeros to follow (example: 474 = 470k ohms)
- 000 = Zero Ohm Jumper

Resistance Tolerance

- J = $\pm 5\%$ (2, 4, 8 resistor pkg. and for Zero Ohm Jumper)
- F = $\pm 1\%$ (4 resistor pkg. and CAT16-F8)

Resistors

- 2 = 2 Isolated Resistors
- 4 = 4 Isolated Resistors
- 8 = 8 Isolated Resistors

Terminations

- LF = Tin-plated (RoHS compliant)

Soldering Profile for RoHS Compliant Chip Resistors and Arrays

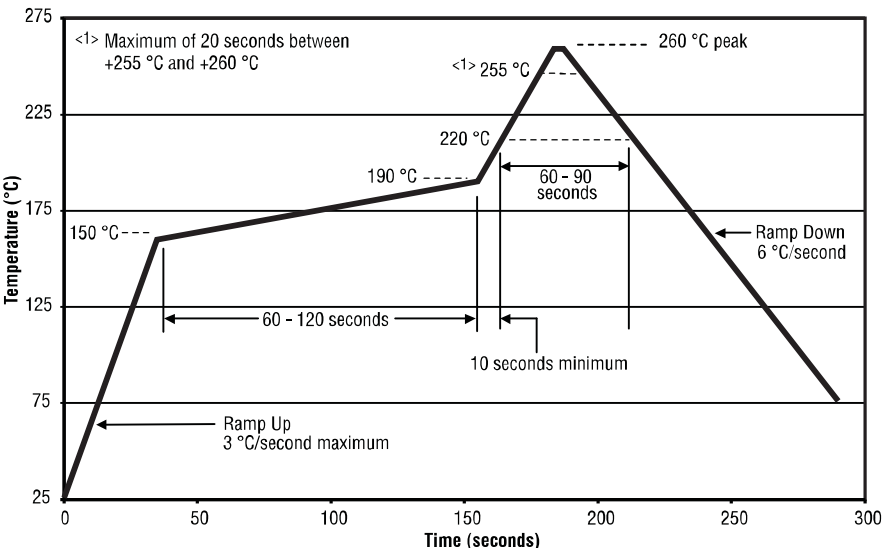

Packaging Size

J2 0606 Package Size
 F4, J4 1206 Package Size
 F8 2406 Package Size for CAT16
 J8 2406 Package Size for CAT16;
 1506 Package Size for CAY16

For Standard Values Used in Capacitors, Inductors, and Resistors, [click here](#).

*RoHS Directive 2002/95/EC Jan. 27, 2003 including annex and RoHS Recast 2011/65/EU June 8, 2011. Specifications are subject to change without notice. The device characteristics and parameters in this data sheet can and do vary in different applications and actual device performance may vary over time. Users should verify actual device performance in their specific applications.

CAT/CAY 16 Series - Chip Resistor Arrays

BOURNS®

Derating Curve

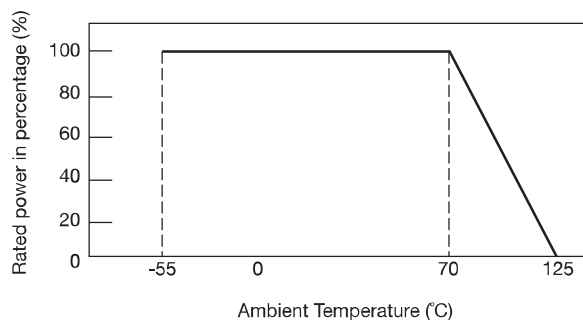

Schematics

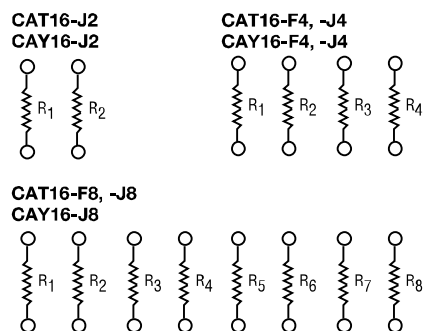

Dimensions

Model	A	A'	B	C	D	E	F
CAT16-F4	$\frac{0.40 \pm 0.15}{(.016 \pm .006)}$	—	$\frac{3.20 \pm 0.20}{(.126 \pm .008)}$	$\frac{0.80 \pm 0.10}{(.032 \pm .004)}$	$\frac{1.60 \pm 0.20}{(.063 \pm .008)}$	$\frac{0.50 \pm 0.10}{(.020 \pm .004)}$	$\frac{0.30 \pm 0.15}{(.012 \pm .006)}$
CAT16-J4	$\frac{0.40 \pm 0.15}{(.016 \pm .006)}$	—	$\frac{3.20 \pm 0.20}{(.126 \pm .008)}$	$\frac{0.80 \pm 0.10}{(.032 \pm .004)}$	$\frac{1.55 \pm 0.25}{(.061 \pm .0098)}$	$\frac{0.50 \pm 0.10}{(.020 \pm .004)}$	$\frac{0.30 \pm 0.20}{(.012 \pm .008)}$
CAY16-F4, -J4	$\frac{0.50 \pm 0.15}{(.002 \pm .006)}$	$\frac{0.70 \pm 0.10}{(.027 \pm .004)}$	$\frac{3.20 \pm 0.20}{(.126 \pm .008)}$	$\frac{0.80 \pm 0.05}{(.032 \pm .002)}$	$\frac{1.60 \pm 0.20}{(.063 \pm .008)}$	$\frac{0.50 \pm 0.10}{(.020 \pm .004)}$	$\frac{0.30 \pm 0.20}{(.012 \pm .008)}$
CAT16-J2	$\frac{0.40 \pm 0.15}{(.016 \pm .006)}$	—	$\frac{1.60 \pm 0.15}{(.063 \pm .006)}$	$\frac{0.80 \pm 0.05}{(.032 \pm .002)}$	$\frac{1.60 \pm 0.15}{(.063 \pm .006)}$	$\frac{0.60 \pm 0.15}{(.024 \pm .006)}$	$\frac{0.30 \pm 0.20}{(.012 \pm .008)}$
CAY16-J2	—	$\frac{0.60 \pm 0.15}{(.024 \pm .006)}$	$\frac{1.60 \pm 0.15}{(.063 \pm .006)}$	$\frac{0.76 \pm 0.10}{(.030 \pm .004)}$	$\frac{1.60 \pm 0.15}{(.063 \pm .006)}$	$\frac{0.45 + 0.15/-0.10}{(.018 + 0.006/-0.004)}$	$\frac{0.30 \pm 0.20}{(.012 \pm .008)}$
CAT16-F8, -J8	$\frac{0.40 \pm 0.15}{(.016 \pm .006)}$	—	$\frac{6.40 \pm 0.20}{(.252 \pm .008)}$	$\frac{0.80 \pm 0.15}{(.032 \pm .006)}$	$\frac{1.60 \pm 0.20}{(.063 \pm .008)}$	$\frac{0.60 \pm 0.15}{(.024 \pm .006)}$	$\frac{0.30 \pm 0.20}{(.012 \pm .008)}$
CAY16-J8	$\frac{0.30 \pm 0.15}{(.012 \pm .006)}$	$\frac{0.30 \pm 0.15}{(.012 \pm .006)}$	$\frac{3.80 \pm 0.20}{(.15 \pm .008)}$	$\frac{0.50 \pm 0.05}{(.02 \pm .002)}$	$\frac{1.60 \pm 0.20}{(.063 \pm .008)}$	$\frac{0.50 \pm 0.10}{(.02 \pm .004)}$	$\frac{0.30 \pm 0.15}{(.012 \pm .006)}$

Configurations

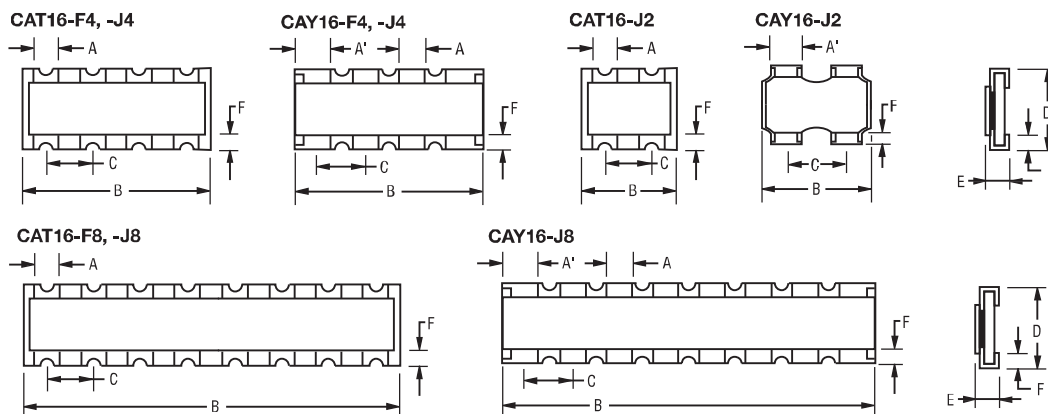

DIMENSIONS: $\frac{\text{MM}}{\text{(INCHES)}}$

Specifications are subject to change without notice.
The device characteristics and parameters in this data sheet can and do vary in different applications and actual device performance may vary over time.
Users should verify actual device performance in their specific applications.

CAT/CAY 16 Series - Chip Resistor Arrays

BOURNS®

Land Patterns

CAT16-F4, -J4, -F8, -J8

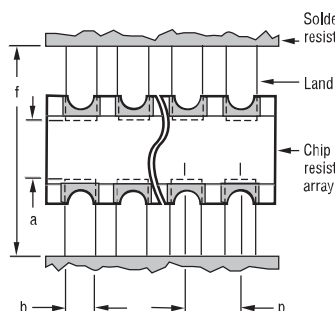

CAY16-F4, -J4, -J8

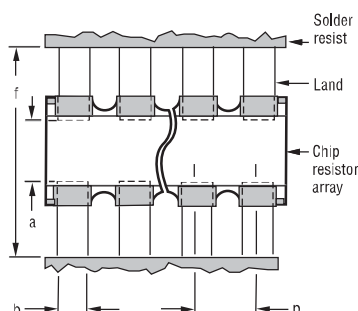

CAT16-J2

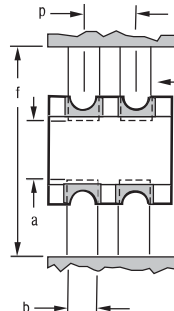

CAY16-J2

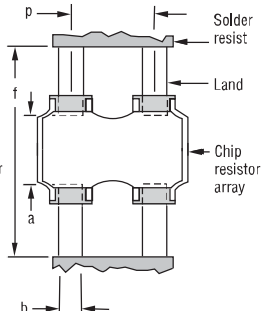

Model	a	b	p	f
CAT16-F4, -J4, -F8, -J8	$\frac{0.7 \text{ to } 0.9}{(.028 \text{ to } .035)}$	$\frac{0.4 \text{ to } 0.45}{(.016 \text{ to } .0178)}$	$\frac{0.80}{(.032)}$	$\frac{2.2 \text{ to } 2.6}{(.087 \text{ to } .102)}$
CAY16-F4, -J4	$\frac{0.7 \text{ to } 0.9}{(.028 \text{ to } .035)}$	$\frac{0.4 \text{ to } 0.45}{(.016 \text{ to } .0178)}$	$\frac{0.80}{(.032)}$	$\frac{2.4 \text{ to } 2.8}{(.094 \text{ to } .11)}$
CAY16-J8	$\frac{0.7 \text{ to } 0.9}{(.028 \text{ to } .035)}$	$\frac{0.3 \text{ to } 0.35}{(.012 \text{ to } .014)}$	$\frac{0.50}{(.020)}$	$\frac{2.0 \text{ to } 2.2}{(.079 \text{ to } .087)}$
CAT16-J2	$\frac{0.7 \text{ to } 0.9}{(.028 \text{ to } .035)}$	$\frac{0.4 \text{ to } 0.45}{(.016 \text{ to } .0178)}$	$\frac{0.80}{(.032)}$	$\frac{2.2 \text{ to } 2.6}{(.087 \text{ to } .102)}$
CAY16-J2	$\frac{0.7 \text{ to } 0.9}{(.028 \text{ to } .035)}$	$\frac{0.4 \text{ to } 0.5}{(.016 \text{ to } .020)}$	$\frac{0.80}{(.032)}$	$\frac{2.0 \text{ to } 2.6}{(.079 \text{ to } .102)}$

Packaging Dimensions

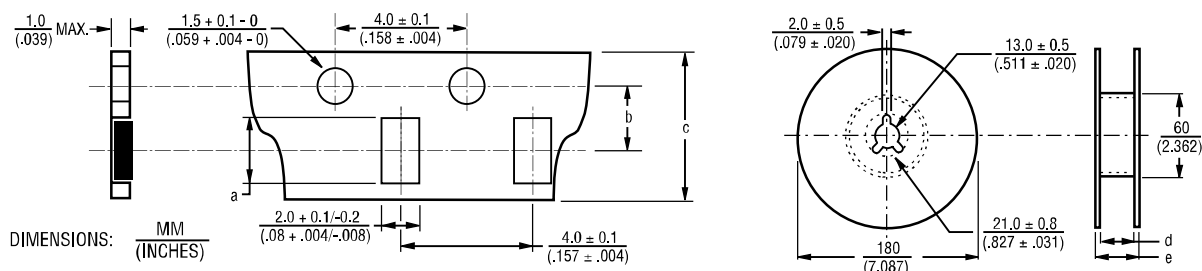

Model	a	b	c	d	e
CAT16-F4, -J4 & CAY16-F4, J4	$\frac{3.60 \pm 0.20}{(.142 \pm .008)}$	$\frac{3.50 \pm .005}{(.138 \pm .004)}$	$\frac{8.0 \pm 0.3}{(.315 \pm .012)}$	$\frac{9.0 \pm 0.3}{(.354 \pm .012)}$	$\frac{11.4 \pm 1.0}{(.449 \pm .040)}$
CAT16-J2 & CAY16-J2	$\frac{1.80 \pm 0.10}{(.070 \pm .004)}$	$\frac{3.50 \pm .005}{(.138 \pm .004)}$	$\frac{8.0 \pm 0.3}{(.315 \pm .012)}$	$\frac{9.0 \pm 0.3}{(.354 \pm .012)}$	$\frac{11.4 \pm 1.0}{(.449 \pm .040)}$
CAT16-F8, -J8	$\frac{6.90 \pm 0.20}{(.272 \pm .008)}$	$\frac{5.50 \pm 0.10}{(.217 \pm .004)}$	$\frac{12.0 \pm 0.2}{(.472 \pm .008)}$	$\frac{13.0 \pm 0.2}{(.512 \pm .008)}$	$\frac{15.4 \pm 1.0}{(.606 \pm .040)}$
CAY16-J8	$\frac{4.10 \pm 0.15}{(.161 \pm .012)}$	$\frac{3.50 \pm 0.05}{(.138 \pm .002)}$	$\frac{8.0 \pm 0.3}{(.315 \pm .012)}$	$\frac{9.0 \pm 0.3}{(.354 \pm .012)}$	$\frac{11.4 \pm 1.0}{(.449 \pm .040)}$

- 5,000 pcs. per reel (J2, J4, CAY16-J8)
- 4,000 pcs. per reel (CAT16-F8, -J8)
- Paper tape

REV. 09/14

Specifications are subject to change without notice. Users should verify actual device performance in their specific applications.

The device characteristics and parameters in this data sheet can and do vary in different applications and actual device performance may vary over time.

Chip Resistor Arrays - Application Note

BOURNS®

Component Placement

- Reduce the mechanical stress to a minimum during and after placing of the unit in order not to damage the terminals and protective coating.
- Misplacement of components may cause solder bridges.

Soldering

- Reflow soldering: Recommendation is shown in the following chart.
- Wave soldering: Recommendation according to IEC standards.
- Hand soldering: Don't touch the protective coating of the part. Solder within 3 seconds when the temperature is over 280 °C.

