



## Jiangsu Weida Semiconductor Co., Ltd.

### BT152 Series 20A Triacs

#### DESCRIPTION:

With high ability to withstand the shock loading of large current, BT152 series of silicon controlled rectifiers provide high dv/dt rate with strong resistance to electromagnetic interference. They are especially recommended for use on solid state relay, motorcycle, power charger, T-tools etc.

#### MAIN FEATURES:

symbol	value	unit
$I_{T(RMS)}$	20	A
$V_{DRM}/V_{RRM}$	600/800	V
$I_{GT}$	25	mA

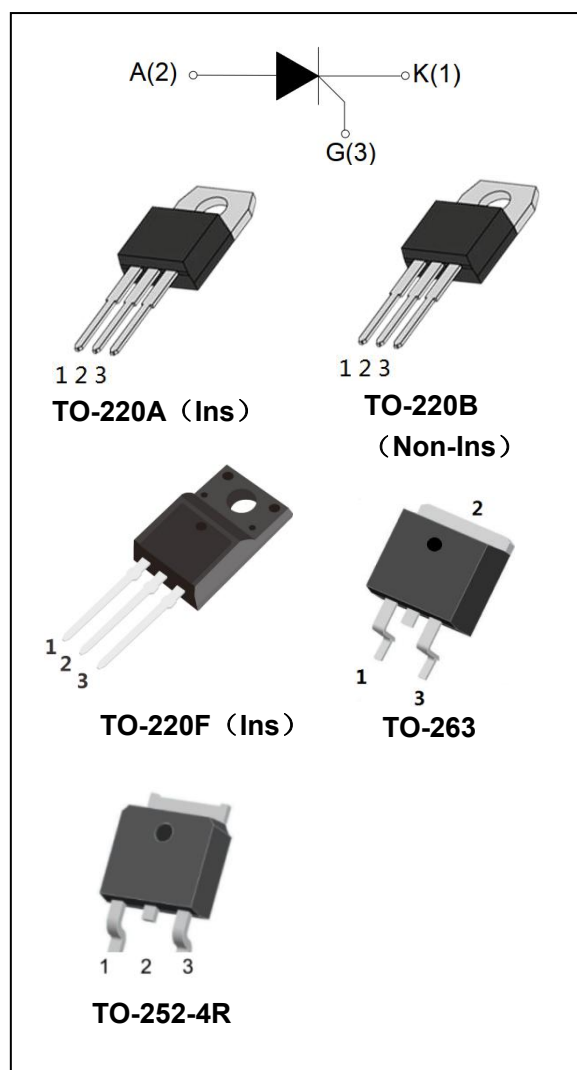

#### ABSOLUTE MAXIMUM RATINGS:

Parameter	Symbol	Value	Unit
Storage junction temperature range	$T_{stg}$	-40~150	°C
Operating junction temperature range	$T_j$	-40~125	°C
Repetitive peak off-state voltage ( $T_j=25^\circ\text{C}$ )	$V_{DRM}$	600/800	V
Repetitive peak reverse voltage ( $T_j=25^\circ\text{C}$ )	$V_{RRM}$	600/800	V
RMS on-state current	$I_{T(RMS)}$	20	A
Non repetitive surge peak on-state current (full cycle, F=50Hz)	$I_{TSM}$	200	A
$I^2t$ value for fusing ( $t_p=10\text{ms}$ )	$I^2t$	312.5	$\text{A}^2\text{s}$



## Jiangsu Weida Semiconductor Co., Ltd.

### BT152 Series 20A Triacs

Critical rate of rise of on-state current( $I_G=2\times I_{GT}$ )	$di/dt$	50	A/ $\mu$ s
Peak gate current	$I_{GM}$	4	A
Average gate power dissipation	$P_{G(AV)}$	1	W
Peak gate power	$P_{GM}$	5	W

### ELECTRICAL CHARACTERISTICS ( $T_j=25^\circ\text{C}$ unless otherwise specified)

Parameter	Test Condition	MIN	TYPE	MAX	Unit
$I_{GT}$	$V_D=12\text{V}, R_L=33\Omega$	-	5	25	mA
$V_{GT}$		-	0.8	1.5	V
$V_{GD}$	$V_D=V_{DRM}, T_j=110^\circ\text{C}$	0.2	-	-	V
$I_H$	$I_T=500\text{mA}$	-	-	60	mA
$I_L$	$I_G=1.2I_{GT}$	-	-	70	mA
$dV/dt$	$V_D=2/3\times V_{DRM}, T_j=125^\circ\text{C}$ Gate open	200	-	-	V/ $\mu$ s

### STATIC CHARACTERISTICS

Symbol	Test Condition			Value	Unit	
$V_{TM}$	$I_{TM}=40\text{A}$	$t_p=380\mu\text{s}$	$T_j=25^\circ\text{C}$	MAX	1.55	V
$I_{DRM}$ $I_{RRM}$	$V_D=V_{DRM}=V_{RRM}$		$T_j=25^\circ\text{C}$	MAX	5	$\mu\text{A}$
			$T_j=110^\circ\text{C}$		1	mA

### THERMAL RESISTANCES

Symbol	Test Condition		Value	Unit
$R_{th(j-c)}$	junction to case(AC)	TO-220(Ins)	2.1	$^\circ\text{C/W}$
		TO-220B(Non-Ins)	1.1	
		TO-220F	2.3	
		TO-263	2.5	
		TO-252	2.6	



# Jiangsu Weida Semiconductor Co., Ltd.

## BT152 Series 20A Triacs

### ORDERING INFORMATION

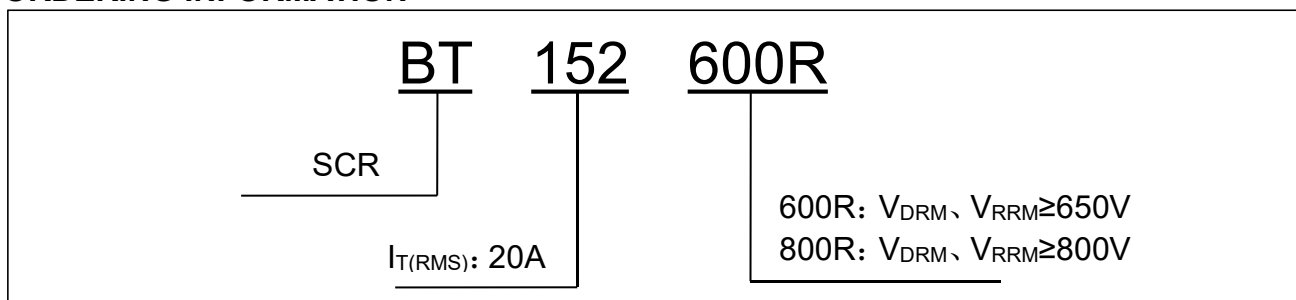

### PACKAGE MECHANICAL DATA

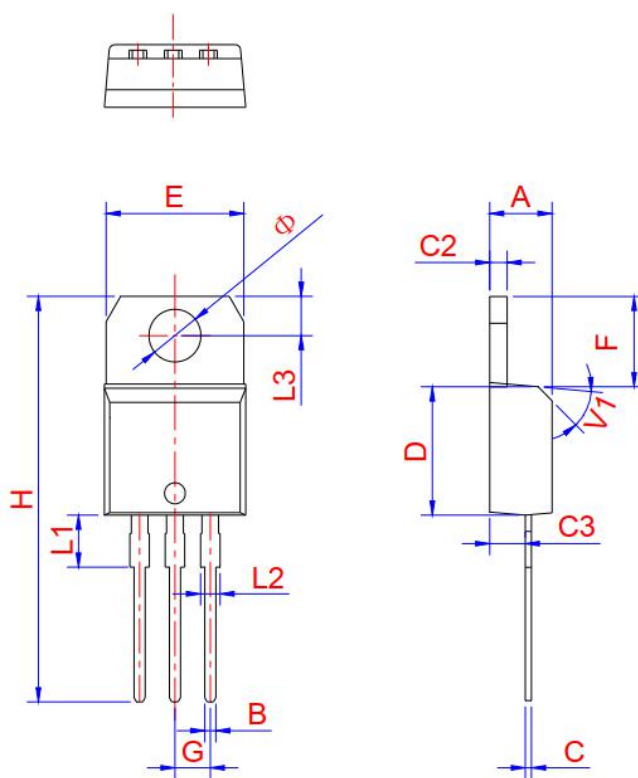

TO-220A Ins

Ref.	Dimensions					
	Millimeters			Inches		
	Min.	Typ.	Max.	Min.	Typ.	Max.
A	4.4	4.47	4.6	0.173	0.176	0.181
B	0.61		0.88	0.024		0.035
C	0.46	0.50	0.7	0.018	0.02	0.028
C2	1.21	1.27	1.32	0.048	0.050	0.052
C3	2.4		2.72	0.094		0.107
D	8.6		9.7	0.339		0.382
E	9.8		10.4	0.386		0.409
F	6.55		6.95	0.258		0.274
G		2.54			0.1	
H	28		29.8	1.102		1.173
L1		3.75			0.148	
L2	1.14		1.7	0.045		0.067
L3	2.65		2.95	0.104		0.116
V1		45°			45°	
Φ	3.7	3.75	3.8	0.145	0.147	0.149



# Jiangsu Weida Semiconductor Co., Ltd.

## BT152 Series 20A Triacs

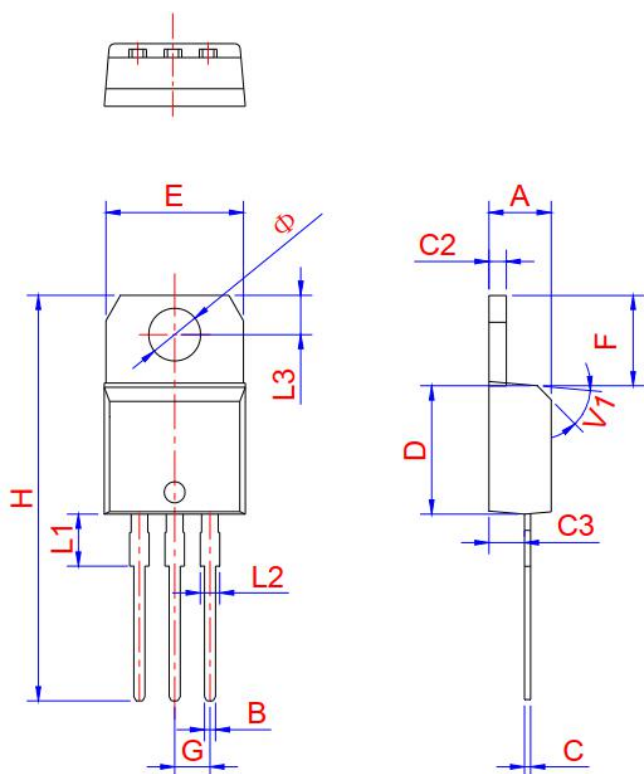

TO-220B Non-Ins

Ref.	Dimensions					
	Millimeters			Inches		
	Min.	Typ.	Max.	Min.	Typ.	Max.
A	4.4	4.47	4.6	0.173	0.176	0.181
B	0.61		0.88	0.024		0.035
C	0.46	0.50	0.7	0.018	0.02	0.028
C2	1.21	1.27	1.32	0.048	0.050	0.052
C3	2.4		2.72	0.094		0.107
D	8.6		9.7	0.339		0.382
E	9.8		10.4	0.386		0.409
F	6.55		6.95	0.258		0.274
G		2.54			0.1	
H	28		29.8	1.102		1.173
L1		3.75			0.148	
L2	1.14		1.7	0.045		0.067
L3	2.65		2.95	0.104		0.116
V1		45°			45°	
Φ	3.7	3.75	3.8	0.145	0.147	0.149

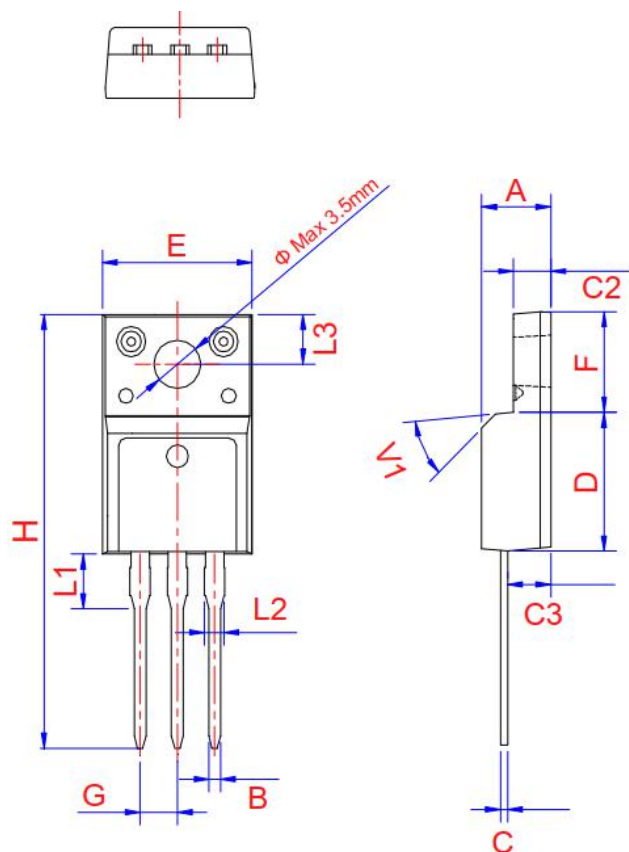

TO-220F Ins

Ref.	Dimensions					
	Millimeters			Inches		
	Min.	Typ.	Max.	Min.	Typ.	Max.
A	4.5		4.9	0.177		0.193
B	0.74	0.8	0.83	0.029	0.031	0.033
C	0.47		0.65	0.019		0.026
C2	2.45		2.75	0.096		0.108
C3	2.6		3	0.102		0.118
D	8.8		9.3	0.346		0.366
E	9.8		10.4	0.386		0.41
F	6.4		6.8	0.252		0.268
G		2.54			0.1	
H	28		29.8	1.102		1.173
L1		3.63			0.148	
L2	1.14		1.7	0.045		0.067
L3	2.65	3.3	0		0.13	0.116
V1		45°			45°	



**Jiangsu Weida Semiconductor Co., Ltd.**  
**BT152 Series 20A Triacs**

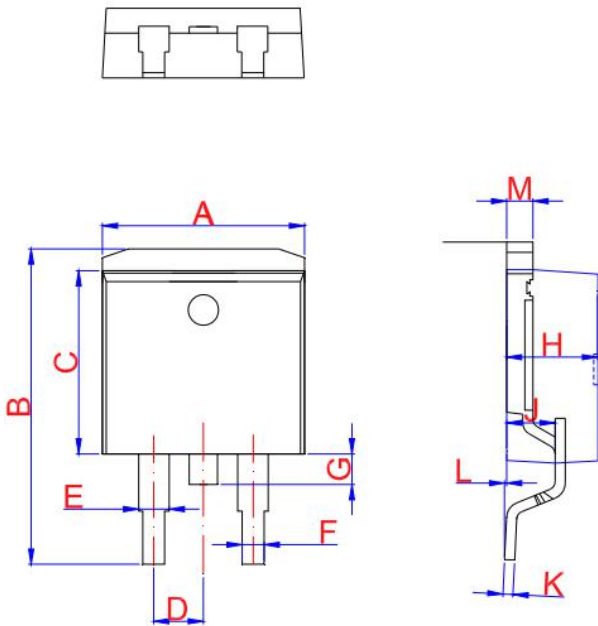

TO-263

Ref.	Dimensions					
	Millimeters			Inches		
	Min.	Typ.	Max.	Min.	Typ.	Max.
A	9.9		10.3	0.390		0.406
B	14.7		15.8	0.579		0.622
C	8.5		8.9	0.370		0.378
D		2.54			0.100	
E	1.20		1.40	0.047		0.055
F	0.75		0.85	0.029		0.033
G			1.75			0.069
H	4.40	4.60	4.80	0.173	0.181	0.189
J	2.40	2.60	2.80	0.094	0.102	0.110
L	0	0.1	0.25	0	0.004	0.010
M	1.17	1.27	1.37	0.046	0.05	0.054

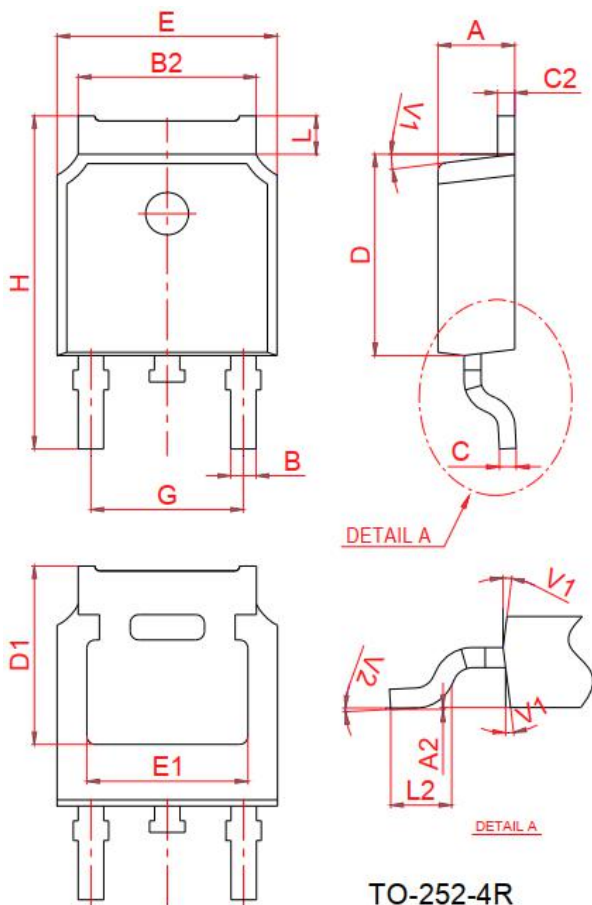

TO-252-4R

Ref.	Dimensions					
	Millimeters			Inches		
	Min.	Typ.	Max.	Min.	Typ.	Max.
A	2.2		2.4	0.087		0.094
A2	0		0.1	0		0.004
B	0.66		0.86	0.026		0.034
B2	5.1		5.46	0.201		0.215
C	0.46		0.58	0.018		0.023
C2	0.44		0.58	0.017		0.023
D	5.9		6.3	0.232		0.248
D1	5.30REF			0.211REF		
E	6.4		6.8	0.252		0.268
E1	4.63			0.182		
G	4.372		4.772	0.172		0.188
H	9.8		10.4	0.386		0.409
L	1.09		1.21	0.043		0.048
L2	1.35		1.65	0.053		0.065
V1		7°			7°	
V2	0°		6°	0°		6°



**Jiangsu Weida Semiconductor Co., Ltd.**  
**BT152 Series 20A Triacs**

**FIG.1:** Maximum power dissipation versus RMS on-state current

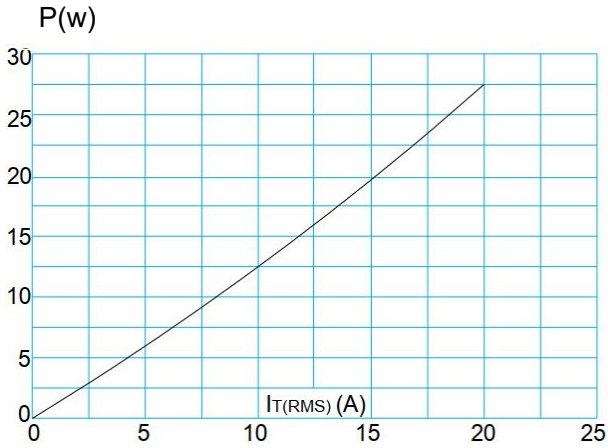

**FIG.3:** Surge peak on-state current versus number of cycles

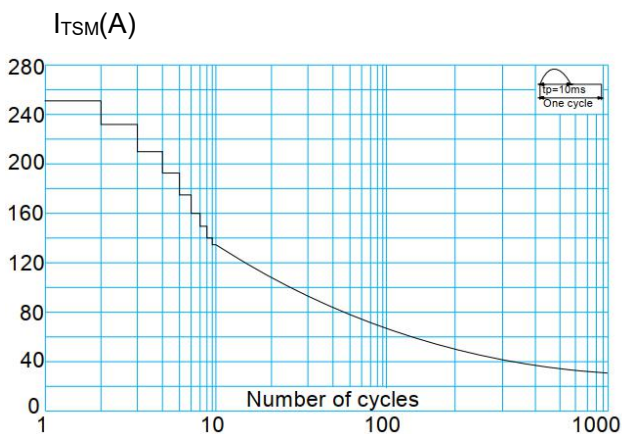

**FIG.5:** Non-repetitive surge peak on-state current for a sinusoidal pulse with width  $t_p < 20\text{ms}$ , and corresponding value of  $I^2t$  ( $I - II - III: di/dt < 50\text{A}/\mu\text{s}; IV: di/dt < 10\text{A}/\mu\text{s}$ )

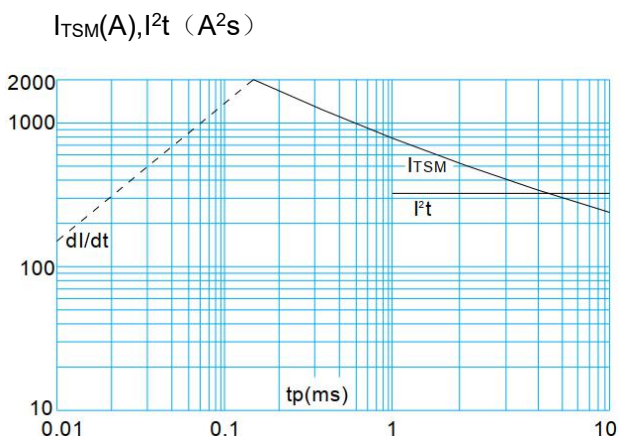

**FIG.2:** RMS on-state current versus case temperature

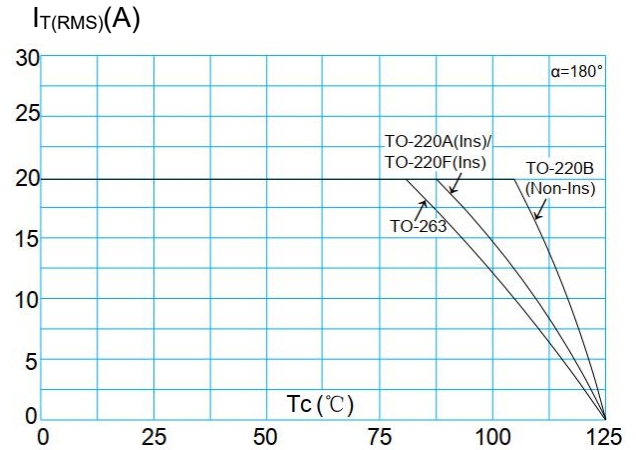

**FIG.4:** On-state characteristics (maximum values)

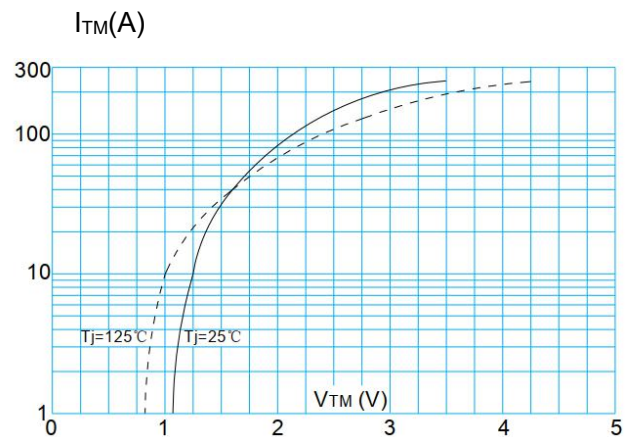

**FIG.6:** Relative variations of gate trigger current, holding current and latching current versus junction temperature

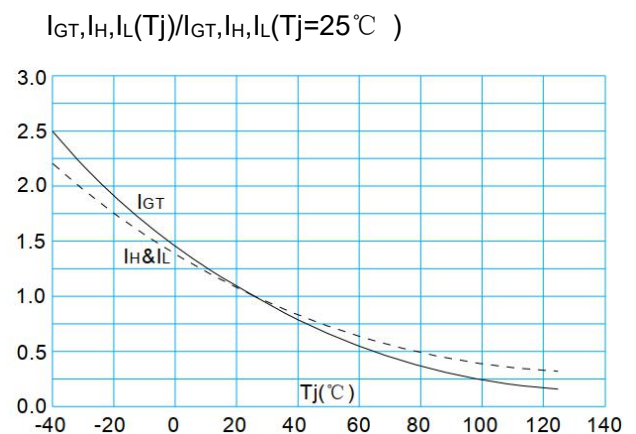



**Jiangsu Weida Semiconductor Co., Ltd.**  
**BT152 Series 20A Triacs**

---

Information furnished in this document is believed to be accurate and reliable. However, Jiangsu Weida Semiconductor Co., Ltd assumes no responsibility for the consequences of use without consideration for such information nor use beyond it.

Information mentioned in this document is subject to change without notice, apart from that when an agreement is signed, Jiangsu Weida Semiconductor Co., Ltd complies with the agreement.

Products and information provided in this document have no infringement of patents. Jiangsu Weida Semiconductor Co., Ltd assumes no responsibility for any infringement of other rights of third parties which may result from the use of such products and information.